

Simulation and optimization of screw feeder in a bubbling fluidized bed gasification reactor

Rajan K. Thapa, Trym Fehn Vaa, Oddvin Vaa, Rajan Jaiswal, Mladen Jecmenica

Department of Process, Energy and Environmental Technology, University of South-Eastern Norway

Rajan.k.thapa@usn.no

Abstract

A fluidized bed biomass gasification reactor is used to produce syngas from biomass and municipal wastes. Gasification is a flexible technology where many different types of feedstocks can be used. The University of South-Eastern Norway has a 20kW gasification reactor which is used to investigate the quality and quantity of the syngas produced using different types of feedstocks. At the present, the reactor has the challenge to supply feedstock to the reactor via transport screws. The main challenge consists of achieving continuous feeding and reduction in the feed rate. Therefore, this work is focused on the optimization of the screw feeder in the gasification reactor to obtain a reduced feed rate while maintaining a continuous feeding rate. The aim is to reduce the feed rate from approximately 8 kg/h to 3-4 kg/h without missing continuity of the feeding.

A model of the screw feeder is developed using CAD software SolidWorks and the model is simulated using open-source simulation software LIGGGHTS to investigate feed rate and continuity using different combinations of transport screw parameters. The simulation results are processed using Excel and viewed graphically with the open-source visualization software ParaView. The simulation results are compared to the experimental measurements in the gasification reactor. The validated model is further used to investigate the feed rate with different combinations of transport screw parameters and the results are compared and discussed.

Keywords: Biomass, Screw Feeder, Open-source LIGGGHTS, CPFD, Simulation

1. Introduction

Feeding the biomass to the gasification reactor at the required rate is essential to achieve higher-quality syngas gas. Therefore, the feeding system for such gasification reactors plays a major role in the utilization of biomass. The most common method to transport feedstock to the reactor has been the use of a screw feeder (Cummer et al., 2002). Due to physical characteristics, moisture content, and heterogeneity of feedstocks, trouble-free transportation of feedstock to the reactor is difficult to obtain (Bandara et al., 2021; Elliott, 1989). The major challenge during the transportation of feedstock to the reactor includes blockage and bridging of the supply line which disrupts the uniform and continuous flow of the feedstock (Bandara et al., 2021; Castleman et al., 1994). During a gasification process, it is important to maintain the required air-to-fuel ratio for the smooth operation of such a reactor at higher efficiency (Jaiswal et al., 2020). The air-to-fuel ratio in a gasification reactor is determined by the amount of oxidizing medium available for supplied feedstock (fuel). When the feedstock supply is lowered to the required air-to-fuel ratio, the quality of syngas is reduced due to the increased carbon dioxide fraction

in the product gas due to partial combustion instead of gasification. On the other hand, if the feedstock is supplied at a higher rate, the supplied heat may not be sufficient for the endothermic reaction to gasify the feedstock. Then, the reactor temperature may drop significantly, reducing the conversion efficiency. Therefore, it is vital to maintain the required flow rate of the biomass.

The University of South-Eastern Norway has a gasification reactor with a capacity of 20 kW and is placed in SINTEF's building that is used for various research.

This work aims to optimize the feeding system for this reactor. Currently, the feeding system of the reactor delivers a high amount of biomass if the reactor is run in continuous mode. The plan for the optimization is to design and produce new feeding screws while keeping the rest of the reactor system in its present condition. These feeding screws need to be able to run continuously while keeping the feed rate not exceeding 3.0 kg/h to 4.0 kg/h.

The optimization process is started by measuring the rotation speed and feed rate of the current screw feeder in the gasification reactor. This measurement gave the baseline data for further optimization. In the next step, a mechanical model of the screw

feeding system is prepared using the CAD software SolidWorks and the model is simulated using an open-source simulation software LIGGGHTS (LAMMPS Improved for General Granular and Granular Heat Transfer Simulations) where LAMMS is Large-scale Atomic/Molecular Massively Parallel Simulator. A series of simulations were performed using different types of screw feeders with different parameters. From the simulation results, three of the screw feeders that gave the best results were taken further for investigation. The screw feeders were made in the mechanical workshop located at the University of South-Eastern Norway.

The screws are then calibrated, and the feed rates are registered. The goal is to optimize the feed rate without changing the reactor or the electrical motors. Other feeding systems than feeding screws are not looked at in this work.

Under the calibrating and registry, blockage and sealing failure and other actual challenges where different biomass will be used are not investigated. Here, the investigations will be done using only the wood pellets as feedstock.

Experiments are run to verify the best screw for the system. This will be done with help from people with a wider range of knowledge when it comes to running the reactor.

2. Material and Methods

First, an attempt has been made to simulate the feeding system using the commercial software SolidWorks. It is found that the program is not qualified for these types of simulations because SolidWorks is more focused on flow simulations and not particle simulations.

After this, another program that USN is licensed to use was tested. This program is called Barracuda Virtual Reactor and is more focused on a mixture of particle and fluid flow simulations. This was acknowledged as a possible candidate for the simulations.

Another attempt was made to use the open-source simulation software LIGGGHTS. The program is found to work a little bit differently than the previously mentioned programs but seemed ok to use for the simulations. This software uses a Discrete Element Method (DEM), and it seems like this gives sufficiently good results for the simulation of wood pellets transferred through the screw feeders. The benefit of using LIGGGHTS is that it uses less processor power than the other software needed for the same situations. It's also easier to use, both with the setup and the change of parameters and variables. Accessibility also has something to say, as CPFD only can be used at USN's campus, which is different from LIGGGHTS which can be utilized anywhere due to it being open-source. It was also checked if LIGGGHTS had been used in earlier

articles and research. It was found in Science Direct 552 articles related to LIGGGHTS simulations. The software doesn't have any completed run files accessible, only the source code. Therefore this will be downloaded and compiled from (LIGGGHTS, 2022). Some small changes were made to the source code to get it to be compiled.

Further, to visualize the results, it was necessary to use a program that could process the files that LIGGGHTS was producing. For this, ParaView was found as open-source software (Ayachit, 2015), and downloaded (ParaView, 2022).

2.1. Simulation of existing feeding system

To make a model that could be used further in the optimizations, it first must be validated. This means that the simulation results produced by LIGGGHTS, must be, if not exact, approximately accurate with the feeding rates from the existing screw feeding system. A series of measurements were carried out in the gasification reactor to measure the feed rate of the biomass pellets using the existing screw feeder. The feeding rate was after 1 hour, 7.67 kg/h at 16 % motor efficiency. This was done by defining the density and size of the particles, different material parameters, contact models for particles against particles, and particles against walls. Friction coefficients also had to be defined for the last-mentioned parameters.

First, a CAD model of the feeding system has been built. The model can be seen in Figure 1. To make the simulations run faster, the model was simplified. This means removing all geometry that doesn't affect the feeding rate. Everything except where the particles flow from the silo is removed. The hot screw also is removed because it was assumed to not affect the feeding rate. The hot screw rotates at a significantly higher speed and has no variation in the pitch.

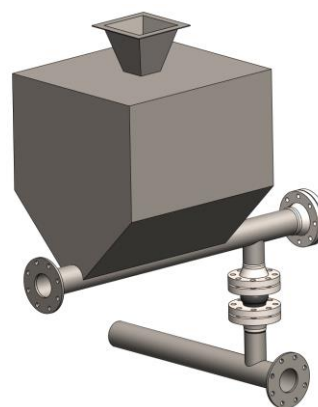

Figure 1: CAD model.

A container was also modeled and is intended to collect all the particles that fall through the descent between the two pipes. This results in a model that can be seen in Figure 2. The origin is set in the back

of the screw because this is the easiest way to make the rotation on the screw, as the screw needs an axis to be defined that it can rotate around.

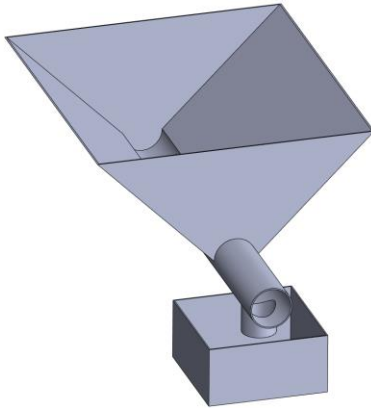

Figure 2: Simplified silo and container.

The model was then exported into STL files that LIGGGHTS could process, and it was only selected surfaces for each part because this is the only thing the software can read. This means 4 different files, one file for each of the components such as a silo, container, feeding screw, and the feed plane. These were exported with a deviation tolerance and an angular tolerance of 1.0 mm and 20.0 °, respectively.

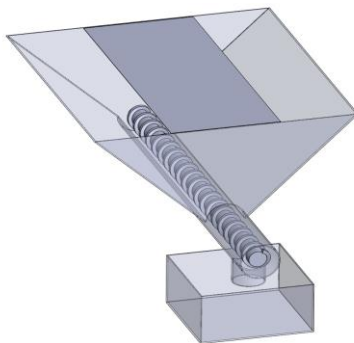

Figure 3: Simplified model.

For the silo, only the inner surfaces were selected, because these surfaces are the only ones that come in contact with the particles. This can be seen in Figure 4.

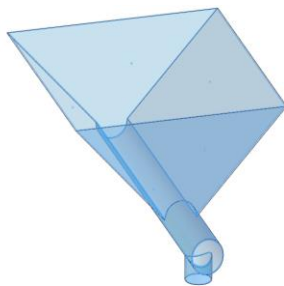

Figure 4: Selected surfaces for the silo.

For the screw, only the outer surfaces were selected, because these are the ones that meet the particles. This can be seen in Figure 5.



Figure 5: Selected surfaces for the screw.

For the container, only the outer surfaces were selected. This can be seen in Figure 6.

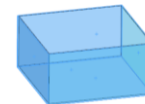

Figure 6: Selected surfaces for the container.

For the feeding plane, only the upper surface was selected from the modeled plate. This was put in the XY plane. This can be seen in Figure 7.



Figure 7: Selected surfaces for the feeding plane.

2.2 Explanation and setup for LIGGGHTS

DEM is an intuitive method with discrete particles colliding with each other and other surfaces through dynamic simulation. Usually, each DEM particle represents a type of granular material. In simulations where particles get exposed to complicated deformations, DEM is not a good method to use. (DEM,2022)

Generally speaking, the contact definitions are easily expandable to include contacts between DEM particles and FEM-based or analytic surfaces. Big relative displacements between particles are typical for applications where DEM is utilized. Particle-to-particle interaction can involve both similar and different particles. Each particle can be involved in many interactions at the same time. (DEM,2022)

The three situations above in Figure 8 show two particles that are just touching, two deformed spherical particles that push each other, and two rigid spherical particles that get pushed into each other with some penetration. (DEM,2022)

To be able to use LIGGGHTS, a program accessed in the form of a text file, that can be obtained from (DEM,2022) and examples found in (LIGGGHTS, 2022).

The decent in the model creates problems when the simulation is starting to run because it gets exposed to many points, and therefore the angles between the points are too small for LIGGGHTS to process.

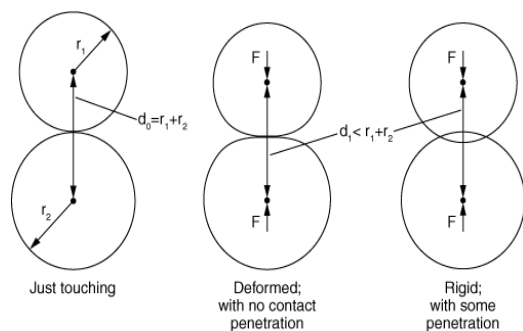

Figure 8: Interaction between spherical particles [5].

Therefore, this pipe will be drawn as a hexagon. The particles have an approximate cylindrical form but can be simplified to be simulated as spherical particles by converting them to spherical equivalent particles. These particles get a density of 1139.0 kg/m³ and 8.96 mm. (Agu et al., 2019) The contact models that are being used are hertz, tangential history, and rolling friction EPSD2 (LIGGGHTS, 2022).

3 Results and discussion

A series of simulations were performed using the simulation software LIGGGHTS. The main parameters used in the simulation are given in Table 1.

Table 1: Simulation Parameters.

Parameter	Value
Particle	-
Density	1139.0 kg/m ³
Diameter	8.96 mm
Modulus of elasticity	-
Particle	5.0 N/mm ²
Wall	2.1e5 N/mm ²
Poissons number	-
Particle	0.45
Wall	0.33
Coefficient of restitution	-
Particle to particle	0.10
Particle to wall	0.20
Frictions coefficient	-
Particle to particle	0.60
Particle to wall	0.52
Rolling coefficient of friction	-
Particle to particle	0.50
Particle to wall	0.45
Simulation time	> 900.0 s
Time increment	5e-5 s
Filling mass (pellets)	7.0 kg

Filling time	4.0 s
Rotational speed	32.43 s ⁻¹
Gravitation	9.81 m/s ²
Timestep	-
Visual data	0.2 s
Mass data	0.2 s

Simulations were run first, using the existing screw feeder. Each simulation was run for a minimum of 900 seconds of simulation time. The flow of particles from the silo through the screw feeder is shown in figure 9.

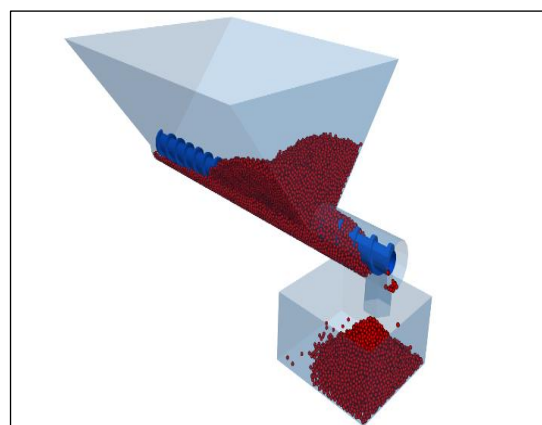

Figure 9: Visualization of the model after 912-second simulation.

Results from the simulation for the existing screw feeder are shown in Figure 10. The results for the first 300 seconds of simulation are not used in validation to avoid starting fluctuation effects.

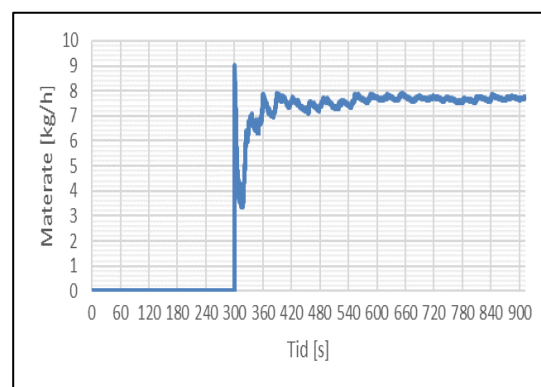

Figure 10: Results of simulation for the feed rate of the existing screw feeder.

The simulation and experimental results for feed rate are found to be 7.30 kg/h and 7.73 kg/h, respectively. The results show that the experimental and simulation results are in good agreement with each other thus the model can be used for further investigations.

Further, three candidate screw feeders with respective diameters of 48mm, 51mm, and 60mm are simulated using different parameters as shown in Figure 11.

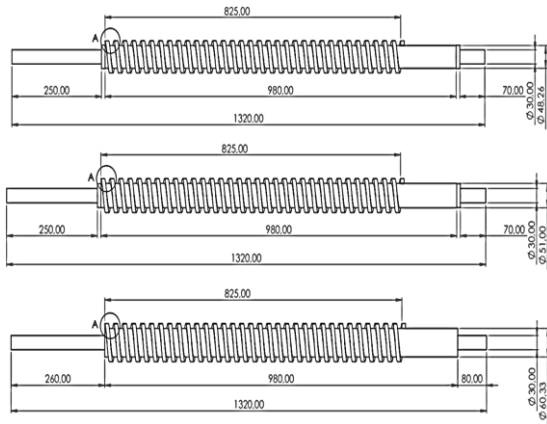

Figure 11: Screw candidates used in simulations.

Each of the screw-feeder was simulated with a varying number of pitches to check the effect of screw diameter as well as the pitch on the feed rate. Figure 12 shows the variation of feed rate with varying diameter and pitch.

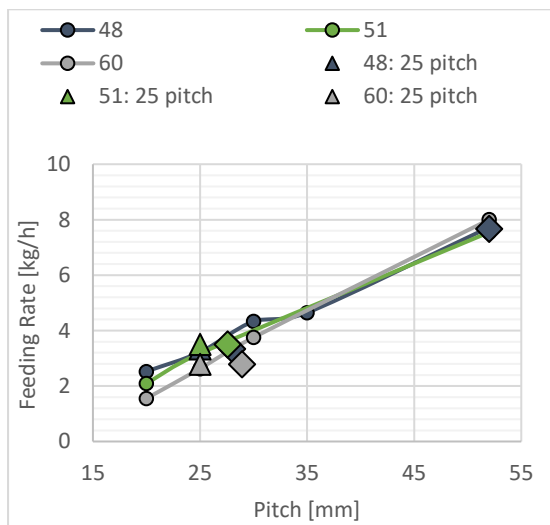

Figure 12: Variation of feed rate with diameter and pitch.

The results of the simulation show that increasing the pitch increases the feed rate. The results of the simulations for the three candidate screw feeders are shown in Figure 13. The results show that all screw feeders give the desired reduction of the feed rate. However, the screw with a diameter of 60 mm gives the minimum feed rate. Therefore, the screw is taken further for testing in the gasification reactor which gives the desired results.

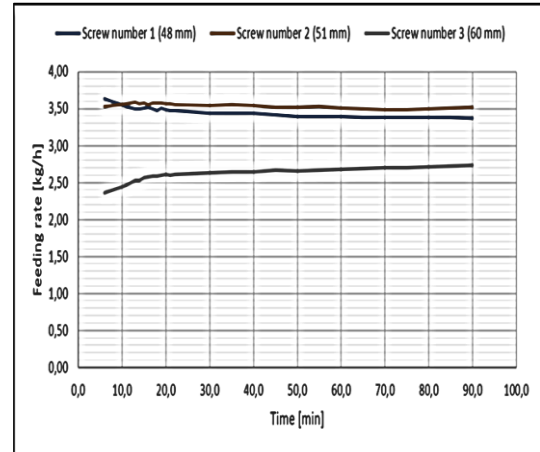

Figure 13: Results of simulation for a feed rate of the three candidate screws.

The simulation results for the candidate screw feeders are compared with the experimental measurements and presented in Table 2.

Table 2: Comparison of the results

Diameter [mm]	Simulated [kg/h]	Measured [kg/h]	Deviation [kg/h]
48	3.37	4.04	0.67
51	3.51	3.67	0.16
60	2.74	3.45	0.71

The results show that the experimental and simulated feed rates for those three candidate screw feeders have good agreements. However, the measured feed rate for the screw feeder with a diameter of 60 mm gave the minimum feed rate. Therefore the screw is installed in the feeding system of the gasification reactor. A gasification experiment was performed with the screw to investigate the gas composition which is compared with the gas composition obtained from the existing screw feeder. The results are shown in Table 3.

Table 3: Comparison of gas composition

Gass	With new screw [%]	With old screw [%]
Oxygen	0.69	0.89
Nitrogen	47.47	53.25
Methane	4.78	3.44
Carbon-monoxide	19.09	14.63
Carbon-dioxide	15.33	16.08
Hydrogen	12.62	11.68

The results show that the energy-containing gasses have increased while nitrogen and carbon dioxide has decreased with the use of the new screw.

4 Conclusions

Experiments were carried out to investigate a feed rate for biomass pellets to a biomass gasification reactor located at USN. A model of the screw feed system of the gasification reactor was made using the CAD software SolidWorks and the model is simulated using fluid-particle flow software LIGGGHTS. The simulation results were compared with experimental measurements to validate the model. A series of simulations were performed with different diameters and pitches of the screw. The screw with a diameter of 60mm gives the minimum feed rate which is desired for the reactor to get continuous feed. Experiments were performed using the new screw to verify again the simulation results. The experimental and simulation results are in good agreement.

Acknowledgments

We would like to thank Øyvind Johanson for providing the materials needed to produce the screws and the use of instruments in the mechanical workshop at USN.

References

- Agu, C. E. et al.(2019), 'Behaviour of biomass particles in a bubbling fluidized bed: A comparison between wood pellets and wood chips, Chemical Engineering Journal, bd. 363,s.84–98,doi:0.1016/j.cej.2019.01.120.
- Ayachit, U. (2015) 'The ParaView Guide: A Parallel Visualization Application.' Clifton Park, NY, USA: Kitware, Inc.
- Bandara, J.C., et al. (2021), ' Air gasification of wood chips, wood pellets and grass pellets in a bubbling fluidized bed reactor. Energy, **233**: p. 121149.
- Castleman, J., C. et al. (1994) 'Fluidized bed combustion and gasification: A guide for biomass waste generators.' Western Regional Biomass Energy Program, Reno, NV (United States).
- CFDEMproject/LIGGGHTS-PUBLIC. DCS Computing GmbH, (2022). Åpnet: 8. February. [Online]. Available on: <https://github.com/CFDEMproject/LIGGGHTS-PUBLIC>
- Cummer, K.R. and Brown, R.C.(2002) 'Ancillary equipment for biomass gasification, Biomass, and Bioenergy, **23**(2): p. 113-128. DEM.[https://abaqus\(2017\)docs.mit.edu/2017/English/SIMACAEANLRefMap/simaanl-c-demanalysis.htm](https://abaqus(2017)docs.mit.edu/2017/English/SIMACAEANLRefMap/simaanl-c-demanalysis.htm) (Accessed 10. May 2022).
- DEM Tutorial 2, 'Screw Conveyor Engineerdo', Engineerdo, 19.september2020. <https://www.engineerdo.com/2020/09/19/dem-tutorial-2-screw-conveyor/> (accessed 1. February 2022).
- Elliott, T.C. (1989), *Standard handbook of powerplant engineering*. 'Gran rolling_friction epsd2 model — LIGGGHTS v3.Documentation. https://www.cfdem.com/media/DEM/docu/gran_rolling_friction_epsd2.html (Åpnet 15. April 2022).
- Jaiswal, R., et al. (2020) 'Study of agricultural waste gasification in an air-blown bubbling fluidized bed using a CPFD model.' ParaView. (accessed 28. February 2022. [Online]. Available on: <https://www.paraview.org/>