

Power Converters Dominated Power Systems

Gonzalez-Longatt, Francisco¹; Acosta Montalvo, Martha Nohemi^{1, 2}; Chamorro, Harold R.³; Rueda Torres, Jose Luis⁴

¹Department of Electrical engineering, Information Technology and Cybernetics - University of South-Eastern Norway

²Universidad Autónoma de Nuevo León - Autonomous University of Nuevo León

³Katholieke Hogeschool Leuven - Catholic College, Louvain

⁴Technische Universiteit Delft Delft University of Technology

Gonzalez-Longatt, F., Acosta Montalvo, M. N., Chamorro, H. R., & Rueda Torres, J. L. (2020). Power Converters Dominated Power Systems. In F. Gonzalez-Longatt & J. L. Rueda Torres (Eds.), *Modelling and Simulation of Power Electronic Converter Dominated Power Systems in PowerFactory* (p. 1-35). https://doi.org/10.1007/978-3-030-54124-8_1

This is the accepted version of an article appearing in *Modelling and Simulation of Power Electronic Converter Dominated Power Systems in PowerFactory* and may appear differently than the finally published version.

Publisher's version: DOI: https://doi.org/10.1007/978-3-030-54124-8_1

1 Power Converters Dominated Power Systems

Francisco Gonzalez-Longatt¹, Martha Nohemi Acosta^{1,2}, Harold R. Chamorro³
and Jose Luis Rueda⁴

¹*Institutt for elektro, IT og kybernetikk, Universitetet I Sørøst-Norge, Porsgrunn, Norway, e-mail: fglongatt@fglongatt.org*

²*School of Mechanical and Electrical Engineering, Universidad Autónoma de Nuevo León, Nuevo León, México, e-mail: martha.acostamnt@uanl.edu.mx*

³*KU Leuven, Katholieke Universiteit Leuven, Leuven, Belgium. e-mail: hr.chamo@ieee.org*

⁴*Department of Electrical Sustainable Energy, Delft University of Technology (TU Delft), Delft, Netherlands, e-mail: J.L.RuedaTorres@tudelft.nl*

Abstract

The transition to a low carbon society is the driving force pushing the traditional power system to increase the volume of non-synchronous technologies which mainly use power electronic converters (PEC) as an interface to the power network. Today, PEC is found in many applications ranging from generation, transmission, storage, and even active loads and protections. The variety of types, applications is almost unlimited. However, the behaviour of PEC is radically different to the typical devices used in traditional power systems, and its specificity in terms of control, overload characteristics, etc., entails an entirely different approach for modelling and simulation. This chapter presents a general review of the main concepts related to power electronic converters and their implementation in DIgSILENT PowerFactory. The chapter finalises with a discussion about the modern tendencies in power electronic applications in power systems: grid following and grid-forming converters.

Keywords: DIgSILENT PowerFactory software, Power Electronic

converters, power semiconductor switches, LCC, CSC, VSC, MMC, back-to-back connection, HVDC.

1.1 Introduction

Power systems are evolving, and now the changes are faster and more profound. The modern power system is changing the way that electricity is produced, transported and consumed. From the generation side, there is a clear tendency to increase the use of environmentally friendly resources like solar power and wind power; all those sources have some sort of intermittency or high variability and also, the modern, efficient ones use *power electronic converters* (PECs) as interfaces to the power network. The power system has changed from the classical model, where the demand dictates the pattern of generation and fully dispatchable generators were able to follow changes in the demand easily. On the other side of the modern power system, the demand side has changed a lot in recent time, novel technologies like electric vehicles (EVs) and small battery energy storage systems (BESSs) are adding. Nowadays the demand has a more complex pattern as never before requiring new ways to see the transmission and distribution system; however, the new PEC-based technologies are more controllable enabling flexibility from the demand point of view [1]. The operation and control of the modern and future power systems have increased complexity, generation and demand have very different patterns, and the transmission system must define appropriate balancing mechanism. The situation at generation and demand sides also makes complex by the pressure created by the market that is increasing stress and narrowly conditions on the transmission system [2].

One common tendency in the revolution of the power system is the massive integration and deployment of PECs at very different levels (transmission and distribution) and applications (generation, transport and use) [3]. The use of PEC has many consequences for the traditional power system; one of them is the massive decoupling between generation/load caused by the use of a DC link. However, there are several other features expected into the future electricity networks will

negatively affect the system security: lack of reactive power support, minimum to none overload capacity, limited short circuit contribution, etc.

The PECs is one of the key elements on the energy transition toward a low carbon power system by allowing a change in generation technology; from fossil fuel-based thermal generation to converter interfaced renewable generation. However, as the penetration of PEC-based technologies increases and the number of classical synchronous generation tends to decline, the power system is looking many positive features coming from the reduced volume of synchronous machines (SMs) (see **Figure 1**): reduced rotating inertia, loss of natural control mechanisms, loss of short circuit contribution, etc.

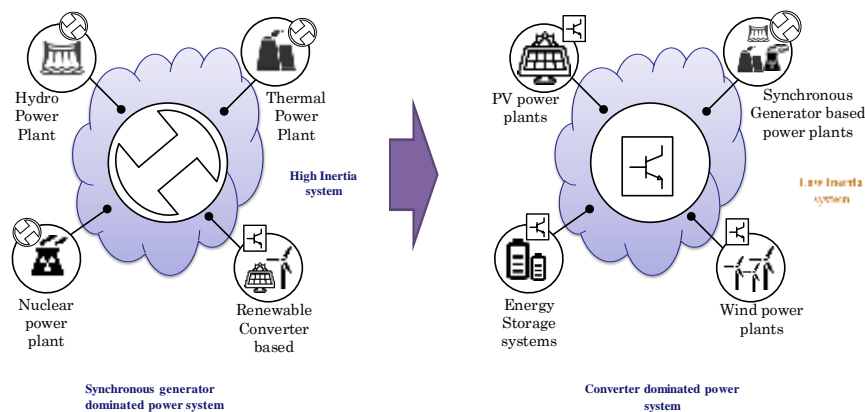

Figure 1: Schematic diagram of a large scale photovoltaic system interconnected to a medium and high voltage network.

1.2 Power Converter Fundamentals

The classical power electronics is dedicated to the study of electronic circuits intended to control the flow of electrical energy. A general energy conversion system is shown in **Figure 2**.

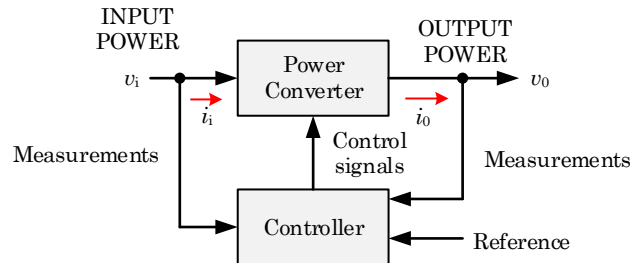

Figure 2: Schematic diagram of a generic energy conversion system showing the main signals and components.

The core of the conversion system in **Figure 2** is the power electronic converter (PEC); it is the energy interface between the components and controls de energy flow (magnitude and direction).

A power electronic converter, usually abbreviated as PEC, is a power electronic-based device that mainly deals with the conversion of power from one form to another, it can involve modifying several electrical parameters like the change from one voltage level to another, differ in frequency, different the number of phases. Power electronics (PE) deals with conversion and control of electrical power with the help of *electronic switching devices*.

The PEC is an enabling technology, and it has been a critical element in the integration of new low-carbon technologies providing the needed interface between two or more energy systems; initial applications of PECs were dedicated to interface source and load. However, modern application of PEC allows energy flow in both directions as a consequence some of the power converters require bi-directionality.

Low carbon technologies based on power electronics conversion are used to guarantee grid and load requirements in terms of controllability and efficiency of the electrical energy demanded. *PEC topologies* convert energy from a primary source to another source (or a load) requiring any level of processed energy [4].

It is useful to categorise the PEC in terms of their input and output form or

frequency. In most power electronic systems, the input is from the electric utility source.

Depending on the application, the PEC output may have any of the following forms [5]:

- Direct current (DC):
 - Regulated (constant) magnitude
 - Adjustable magnitude
- Alternate current (AC):
 - Constant frequency, adjustable magnitude
 - Adjustable frequency and adjustable magnitude

The input and the output side of the PEC are independent of each other, maybe a single-phase or three-phase. The power flow direction is typically from the side connected to the source and going to a load. However, the new low carbon technologies impose exceptions. For example, a classical top-roof photovoltaic (PV) system interfaced with the utility grid via a PEC, the power flow is from the PVs (a DC input source) to the AC utility (as the output load). In some systems, the direction of power flow is reversible, depending on the operating conditions, that is the case of battery energy storage systems (BESSs).

PEC topologies convert energy from a primary source to another source (or a load) requiring any level of processed energy [4]. Classifications of the PEC topologies can be done in terms of the type of variable under control (i.e., AC or DC), as well as the number of stages of power conversions used, as observed in **Figure 3**.

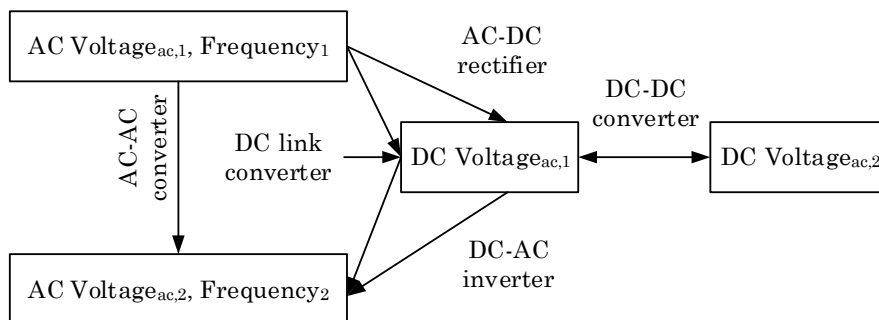

Figure 3: Schematic diagram depicting the relationship between variables at the conversion process.

Figure 3 presents, in a general way, the possible energy conversions available by using PECs. Typically the word converter is used as a generic term for a PEC that can perform energy conversion based on the form (frequency) on the two sides: AC-AC, AC-DC, DC-AC and DC-DC.

A direct AC-AC converter takes an AC waveform and converter that into another AC waveform, where the output voltage and frequency can be set arbitrarily. In this specific case, the PEC converts an AC voltage ($V_{ac,1}$) with a specific frequency (F_{1}) to another AC voltage with a different (or same) voltage ($V_{ac,2}$) and frequency (F_{2}); AC-AC PEC with no intermediate DC link came in the form of cyclo converters and matrix converters.

Special attention is given to the PECs dealing with configurations that process AC voltage (at input and/or output converter sides) with one DC stage. In this case, the term *rectifier* refers to a PEC when the average power flow is from the AC ($V_{ac,1}$, F_{1}) to the DC side ($V_{dc,1}$). *Inverter* refers to the converter when the average power flow is from DC ($V_{dc,1}$) to the AC side ($V_{ac,2}$, F_{2}).

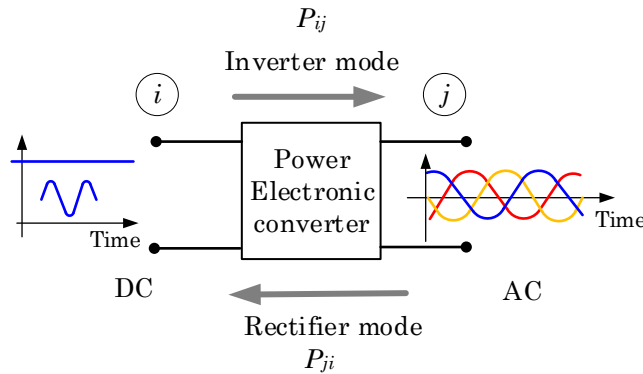

Figure 4: AC-DC converter operation. Operation mode considering the power flow direction between AC and DC.

Finally, the DC-to-DC converters convert one DC voltage level ($V_{dc,1}$) to another ($V_{dc,2}$), which may be higher or lower. The term *buck converter* (step-down converter) is used when the steps down voltage ($V_{dc,1} > V_{dc,2}$) and if the PEC steps up voltage (while stepping down current) from its input (supply) to its output (load) it is referred as a *boost converter* (step-up converter, $V_{dc,1} < V_{dc,2}$). DC-DC converter has multiple applications in power systems, optimising the performance of low carbon technologies is a classic example, where the DC voltage of produced by the PV array is controlled to optimise the power production, a similar situation is found at wind turbines. On the other hand, DC-DC converters have the potential to contribute with the efficient operation of High Voltage Direct Current (HVDC) transmission systems, but at the moment this book is written one of the main challenges is reaching very high conversion ratios ($a = V_{dc,1} / V_{dc,2}$).

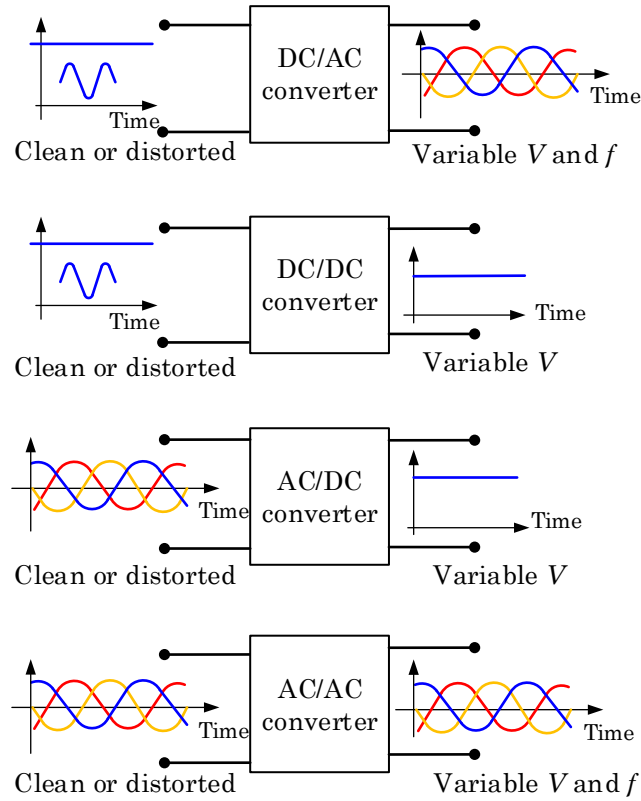

Figure 5: Illustrative diagram showing the power electronic conversion and the relationship with the signals.

1.3 Power electronic switch

An *ideal switch* is a switch that not consume or dissipate any power from its sources.

It as has the following characteristics [4]:

- (i) infinite blocking voltage capability,
- (ii) no current while the switch is off,
- (iii) infinite current capability when on,
- (iv) drop voltage equal to zero while on,
- (v) no switching or conduction losses, and
- (vi) capability to operate at any switching frequency.

An ideal power electronic switch can be represented as a three terminals device, as shown in **Figure 6**. The input (1), the output (2), and a control terminal (3) that imposes on/off conditions on the switch.

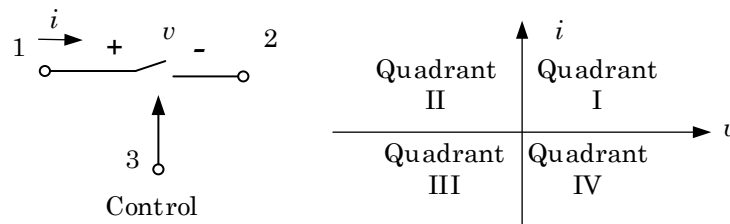

Figure 6: Symbol representing an ideal power electronic switch (left) and four-quadrant switch $v-i$ characteristics (right).

An important characteristic of an ideal switch is that it exhibits zero-power dissipation, carries bidirectional current, and can support bidirectional voltage. A plot of the switch current (i) with respect to its terminal voltage (v) produces a $v-i$ plane with four quadrants (**Figure 6**). By definition, an power electronic switch can operate in all four quadrants.

Considering the power semiconductor devices as ideal switches provide the advantage of making easier the analysis PECs. Using this approach, the details of device operation will not obscure the basic operation of the circuit, making easier the understanding of the underlying concepts. However, the real power semiconductor switching devices have many features to consider, and they might affect the performance of the PEC in some aspects. However, the design and construction of power semiconductor devices focus on how to improve their performance toward the hypothetical concept of an ideal switch. The modern power electronic switches are capable of handling high voltage (HV) and high current operations at high frequency (HF), they are the most important devices needed in the design of energy conversion systems that use PEC.

There are different ways to classify a power semiconductor switch. One simple

classification of the power semiconductor switch is based on the number of terminals:

- *Two-terminal devices*: It is the case of diodes; their state is entirely dependent on the external power circuit they are connected to.
- *Three-terminal devices*: These power semiconductor switches are more frequently found in the PEC and their state is not only dependent on their external power circuit but also the signal on their driving terminal (*gate* or *base*).

Another way to classify the power semiconductor switch considers the type of charge carriers they use:

- Some devices are *majority carrier devices* (Schottky diode, MOSFET, JFET) - use only one type of charge carriers (i.e., either electrons or holes).
- Others are *minority carrier devices* (p-n diode, Thyristor, BJT, IGBT) - use both charge carriers (i.e. electrons and holes).

Finally, a third classification is based on the degree of controllability:

- *Uncontrollable switches*: The power semiconductor switch has no controlling terminal, and the state of the switch (on/off) is determined by the external voltage or current conditions of the circuit in which the switch is connected. An example of these power semiconductor switches is the diode; it conducts current primarily in one direction (asymmetric conductance); it has low (ideally zero) resistance in one direction, and high (ideally infinite) resistance in the other.
- *Semi-controllable switches*: In this case, there is limited control over the power semiconductor switch, there is full control to turn on the switch but uncontrolled turn-off. For instance, the power semiconductor switch can be turned on from the control terminal but once on; it cannot be turned off from the control signal. The power semiconductor switch can be switched off by the operation of the circuit or by an auxiliary circuit that is added to force the power semiconductor switch to turn-off. A *thyristor* or an *SCR* (silicon controlled rectifier) is an example of this switch type.

- *Fully-controllable switches*: This case allows full control of the power semiconductor switch. The power semiconductor switch can be turned on and off via the control terminal. Examples of this power semiconductor switch are the BJT, the MOSFET, the IGBT, the GTO thyristor, *junction gate field-effect transistor* (JFET), and the MOS-controlled thyristor (MCT).

An additional classification of power semiconductor devices includes:

- *Continuous gate signal requirement*: Examples include BJT, MOSFET, IGBT, *static induction transistor* (SIT).
- *Pulse gate requirement*: Some examples of this power semiconductor switches include: SCR, GTO, MCT).
- *Bipolar voltage withstanding capability*: Examples include SCR, GTO.
- *Unipolar voltage withstanding capability*: e.g. BJT, MOSFET, GTO, GBT, *MOS-controlled thyristor* (MCT).
- *Bidirectional current capability*: e.g. Triac, Reverse Conducting Thyristor (RCT).
- *Unidirectional current capability*: e.g. SCR, GTO, BJT, MOSFET, MCT, IGBT, SITH, SIT and diode.

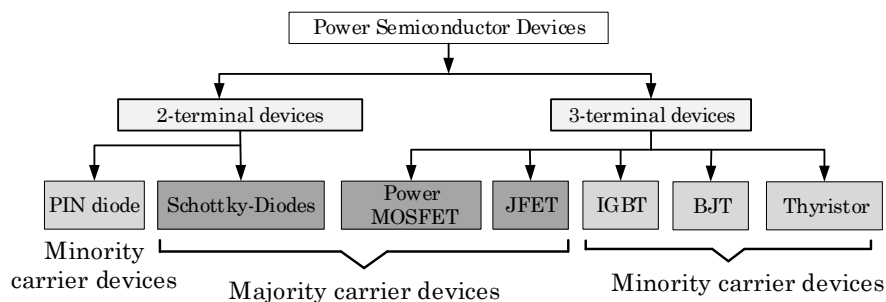

Figure 7: Classification of the power semiconductor switch based on the number of terminals.

The history of power electronics predates the development of semiconductor

devices employed nowadays. The first PECs were conceived in the early 1900s when the *mercury arc rectifiers* were introduced. Until the 1950s, the power switches used to build PECs were *grid-controlled vacuum tube rectifier*, *ignitron*, *phanotron*, and *thyatron*. Two critical events in the evolution of the PECs were the development: (i) Bell Telephone Laboratories invented the silicon transistor in 1948; it allows the development of very low power devices such as in portable radios and (ii) General Electric Company developed the thyristors or SCR in 1958. Initially, the SCR was built by using germaniums and later silicon. It was the first semiconductor power device.

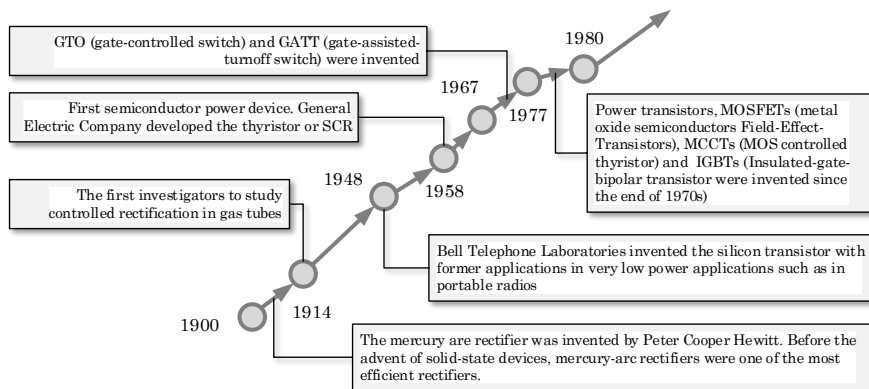

Figure 8: Representative timeline of the most important historical events and developments in the PEC evolution.

One significant step forward in the development of modern PECs was when the thyristor appeared in 1957. The thyristors are power electronic switches with the capacity to withstand very high reverse breakdown voltage at the time that are able to carry very high currents; those characteristics open the possibility of using them at high voltage application as the pioneering HVDC systems. However, one of the major disadvantages of the thyristor is the lack of control to turn off the devices when they are on. It means the switching circuit is that once it is “*latched-on*” in the conducting state (turn on), as a consequence, it cannot be turned off by external control (e.g. gate signal). This characteristic made the thyristor had limited control,

useful in some applications but for the more controllable application was a critical challenge.

In the decade of 1960s, a more controllable power semiconductor switches with enhanced power capabilities were introduced, it was the first *bipolar transistors* device. A clear advantage of this power switch was the capability of a fully controllable turn on or off capability using a control signal, this overcomes an important limitation of the thyristor, but power handling was below the thyristors. The sudden development in the late 1970s of the *Metal Oxide Semiconductor* (MOS) technology allows the power semiconductor switch to overcome some of the critical issues related to the bipolar transistors, the power handling!. By 1970s, the power MOSFET was available, and it allowed the power semiconductor switch to operate at relatively high power than bipolar transistors at the time to operate at a higher frequency. However, the main issue was the limited application to load voltage. Although the *Insulated Gate Bipolar Transistor* (IGBT) was developed in the 1980s, it only becomes widely available by 1990s. The IGBT was able to fully built on top of the power handling capability of the bipolar transistor but adding the advantages of having an isolated gate drive available at the power MOSFET. An illustrative graph is showing a representative timeline of the most important historical events and developments in the PEC evolution and a simplified timeline of the power semiconductor switches and the year of development of each switch are shown in **Figure 9**.

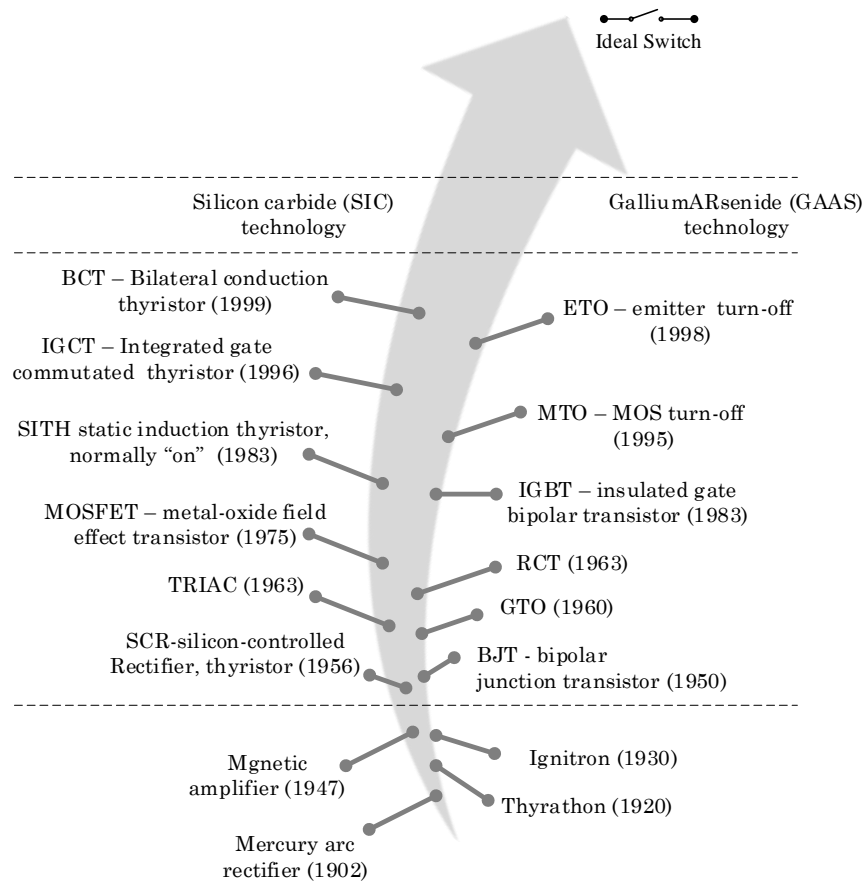

Figure 9: Representative timeline of the most important development of power semiconductor switches toward the development of an ideal switch.

Figure 10 shows a classification of the semiconductor switches based on the semiconductor material used to build the power electronic switch. Classical switches are based on silicon (Si), that material has a breakdown voltage of around 600V. A new generation of power devices based on *Wide Band Gap Semiconductors* such as silicon carbide (SiC) and gallium nitrate (GaN) is used. The modern SiC can withstand voltages 5-10 times higher; also power switches from this material can switch at nearly ten times the rate of silicon, which results in

smaller control circuitry. Additionally, the used of silicon carbide decrease in resistance results in less energy loss during operation, making silicon carbide nearly ten times more efficient at higher voltages than silicon.

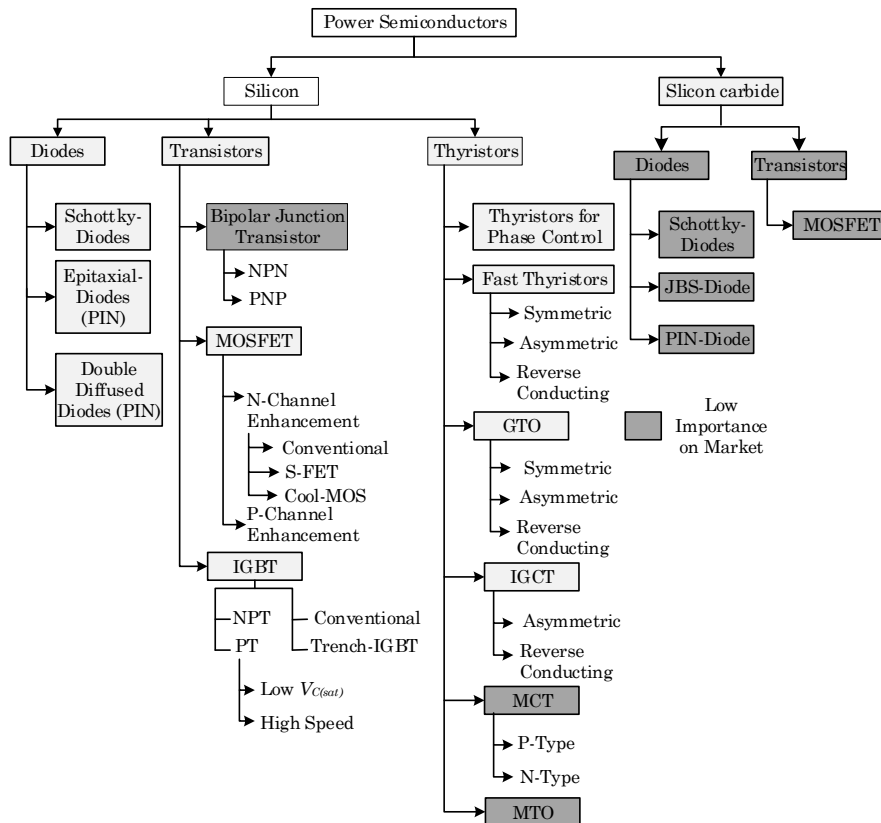

Figure 10: Specific classification power electronic switches based on the semiconductor used: (a) Silicon and (b) Silicon carbide.

Figure 11 and **Figure 12** present an illustrative example of the commonly found power electronic switches indicating the symbols and the representative characteristics.

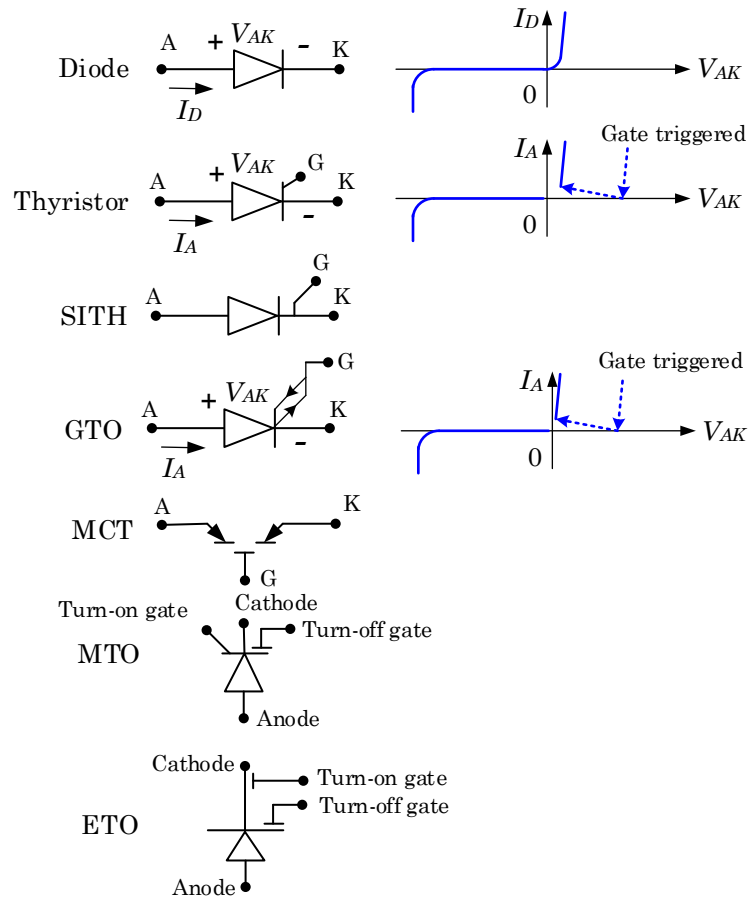

Figure 11: Representative Characteristic and Symbol of Power Electronic Devices: PART I.

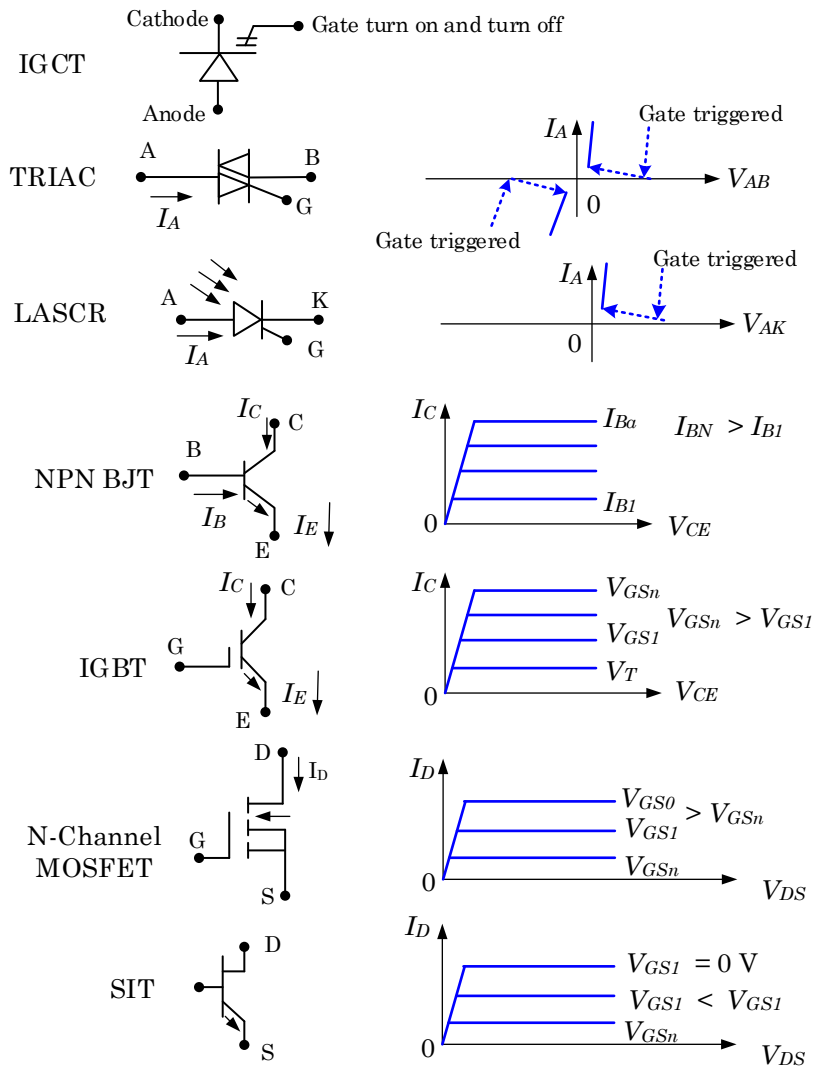

Figure 12: Representative Characteristic and Symbol of Power Electronic Devices: PART II.

Finally, **Figure 13** shows a comprehensive summary of the primary commonly used power electronic switching devices considering the rated current, rated voltages and the frequency range of use.

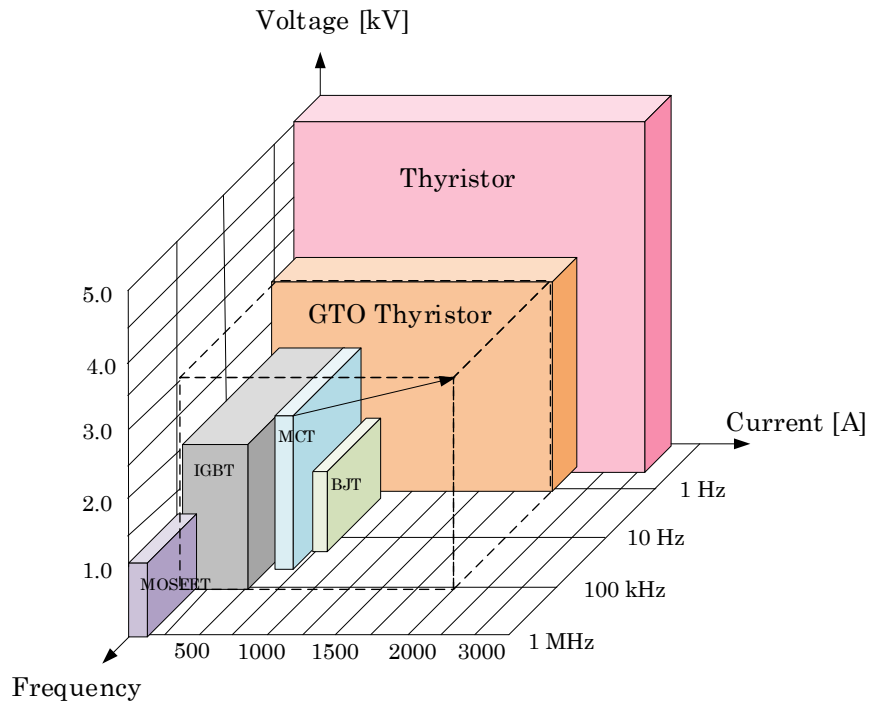

Figure 13: Maximum characteristics (voltage, current, frequency) of some power semiconductor switches.

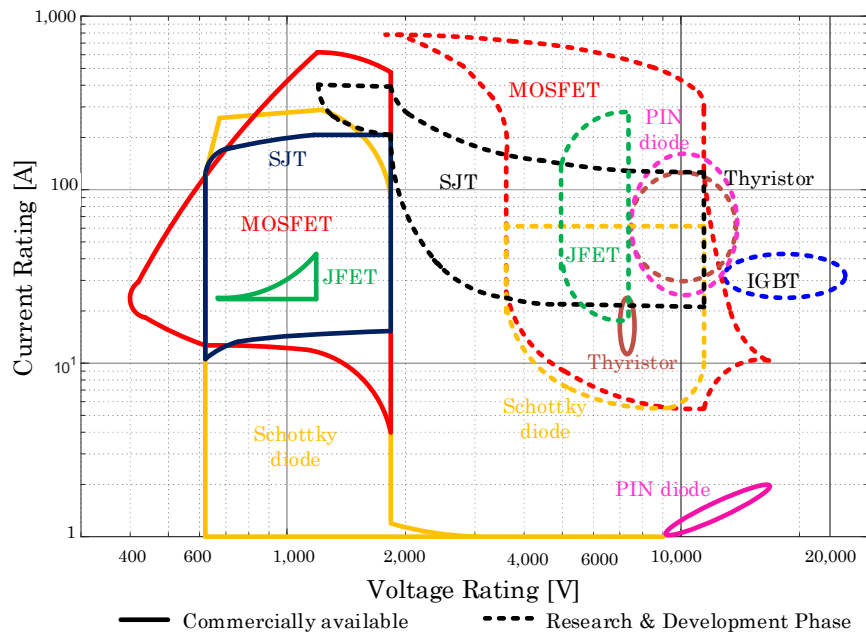

Figure 14: Rating characteristics (voltage and current) of some power semiconductor switches.

1.4 Power Semiconductor switches in DigSILENT PowerFactory

DigSILENT PowerFactory version 2020 includes a model for a power semiconductor switches. It is a network element named *ElmValve*, and it is used to model and simulated the behaviour of different semiconductor devices. The DC valve element (as called in the *User's Manual of DigSILENT PowerFactory*) has the limitation that can be connected to DC terminals (*ElmTerm*), as a consequence, it is not possible to use it at AC terminal.

The network element DC valve can be configured to model and simulate three different types of switching: (1) *No controllable device*, as the case of a classical diode at the network element has two terminals, or (2) *Semi-controllable* (only turn on) like the case of classical thyristor, and (3) *Fully controllable (turn on/off)* like Gate

Turn-Off thyristor (GTO), Integrated Gate-Commutated Thyristor (IGCT), Isolated Gate Bipolar Transistor (IGBT). The semi-controllable and fully controllable DC valves have a third terminal that is used for control purposes.

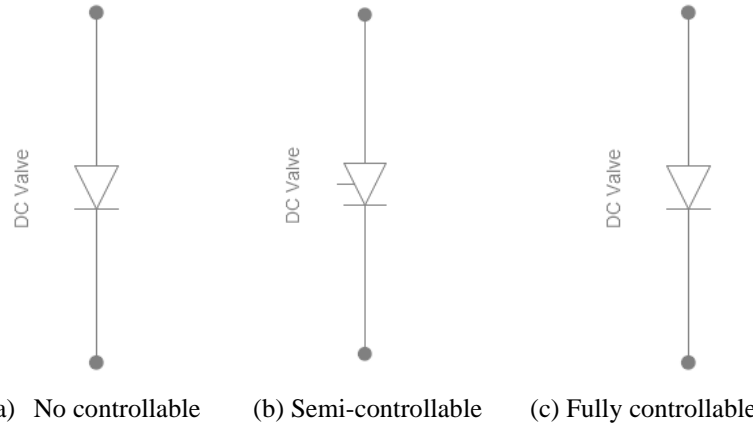

Figure 15: Symbol representation of element DC valve (ElmValve) depending on the types of switching.

Understanding the state change control of the element DC valve is key in order to use it inside DIgSILENT PowerFactory properly. The model of the DC valve element for the time domain simulation includes two main components: (i) the internal conductance (G_{off}) and the internal resistance (R_{on}) dedicated to the switch position and (ii) a parallel snubber circuit consisting of an internal parallel conductance (G_p) and an internal parallel capacitance (C_p). Semi-controllable and controllable devices have an input signal called “gate”, using a DSL model the signal for controlling the device can be appropriately generated depending on the application. The element DC valve has a state named capacitance-voltage in volts.

A very illustrative example of the use of ElmValve can be found in the example “*Offshore wind farm*”, it shows an offshore windfarm connected via a VSC HVDC link, where a controllable chopper is located at the onshore converter station. Details of the controller generating the signals of the ElmValve are presented in the *OnshoreChopperCtrl.BlkDef*.

1.5 Basic PECs

A PEC is typically used to interface a system that can define as an energy provider (source) and energy user (load or source). The energy provider (or source) can be considered either of voltage type or current type. Also, the energy user can be of either voltage type (e.g., a capacitive load) or current type (e.g., an inductive load).

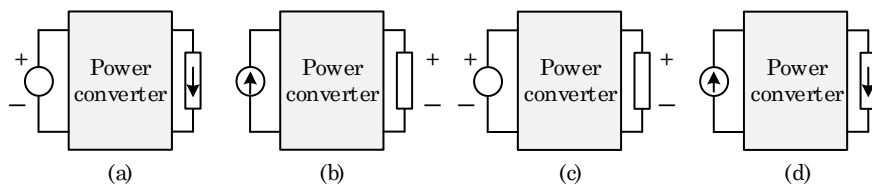

Figure 16. General representation of the four possible uses of PECs.

Figure 16 shows a general schematic diagram depicting the four possible uses of a PECs as an interface between energy provided and user: (a) $V-I$, (b) $I-V$, (c) $V-V$ and (d) $I-I$. The $V-V$ (**Figure 16.c**) connection involves the PEC interfacing load and source are expected to have an inductor element inside that block, and the same rationale applies for $I-I$ (**Figure 16.d**).

The *commutation cell* is the basic structure in PEC. It is composed of a power switch; nowadays a high-power semiconductor switch is used instead of a mechanical switch. A PEC makes use of a configuration of power semiconductor devices that function as switches; switches are closed and open in a systematic way allowing the power conversion. Whenever a switch is turned off, the path of current flow changes, that is a commutation of current away from that switch. These are made to turn on and off repetitively in such way as to implement the required conversion function.

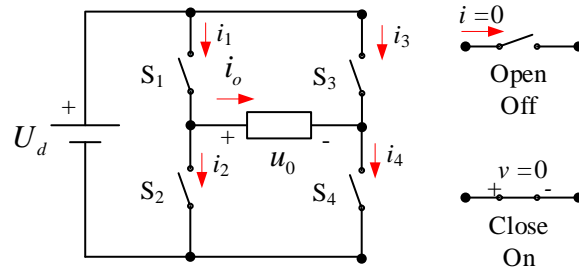

Figure 17. An illustrative example of a PEC showing ideal switches and the possible states (on/off).

The basic commutation cells allow the PECs to convert energy from DC-DC, DC-AC, AC-DC, and AC-AC and also to extend them to more complex structures, in a more systematic way.

As a basic illustration in this chapter, a simple PEC topology of a DC-AC converter is shown in **Figure 18**. This circuit allows the power conversion from DC to AC; it is an inverter. The inverters can be categorised as *voltage-source inverters* (VSIs), *current-source inverters* (CSIs), and *impedance-source inverters* (ZSIs).

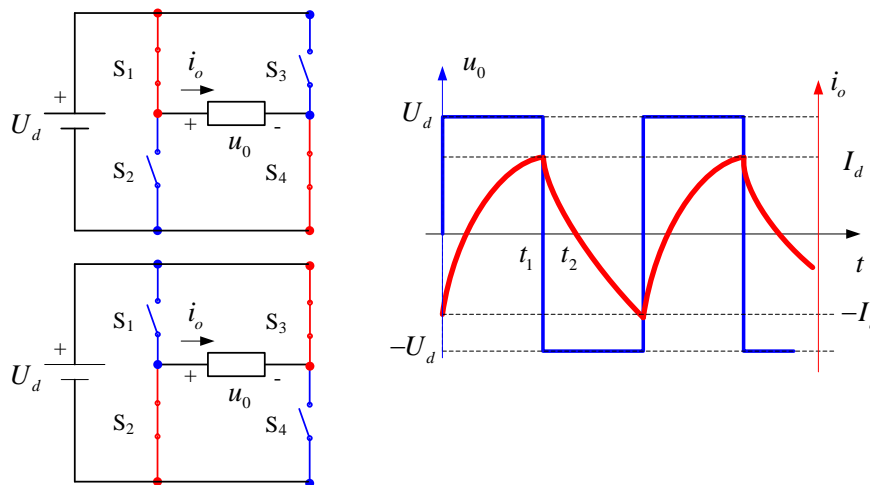

Figure 18: Illustrative topology of a single-phase DC-AC PEC (a) full-bridge inverter topology is shown (left side, top positive semi cycle); (b) the output waveforms of voltage (u_0) and current (i_0) for a *duty cycle* of $d = 0.5$.

The term commutation, in the context of PECs, means the transfer of currents from one path to another. The *commutation process* takes place with the appropriate sequencing of closing and opening the power switches. Two main types of communication process can be identified:

- *Circuit-dependent parameters*: it depends on circuit topology, and include components such as transformer leakage (inductor), commutation capacitor, auxiliary switching device, etc.
- *Switch-dependent-parameters*: it includes device turn-on and turn-off times, di/dt and dv/dt limitations, etc. The most significant switch dependent parameter is turn-off time since the switches are not perfect; their turn-off times are finite and impact on the commutation process.

Table 1 shows summary between the type of devices and the communication type. It is evident that modern power semiconductor switches as the GTO, IGBT and MCT have the possibility of turning on and off by using a gate signal.

Table 1. Summary of the main type of power electronic switching devices and its commutation type and characteristic.

Type of Device	Commutation	Initiated by
Conventional Thyristor	Line	AC line voltage
	Circuit (or Capacitor)	Capacitor voltage
GTO, IGBT or MCT	Self	Gate drive

1.6 Power Electronic Converters in Power Systems Applications

An illustrative diagram showing the main application of power electronic converter inside power systems is shown in **Figure 19**. The diagram shows the uses of power electronic converters in several areas of the power systems: the generation side, transmission, distribution and end-user side. The power electronic converter is a key technology for all those sub-systems and has spread in many applications, examples including:

- *Low voltage residential sector*: heat pumps;
- *Commercial sector*: Uninterruptible Power Supply (UPS), battery chargers;
- *Industrial sector*: variable speed of induction machines;
- *Transportation sector*: charger stations of electric vehicles;
- *Transmission sector*: High Voltage direct current (HVDC);

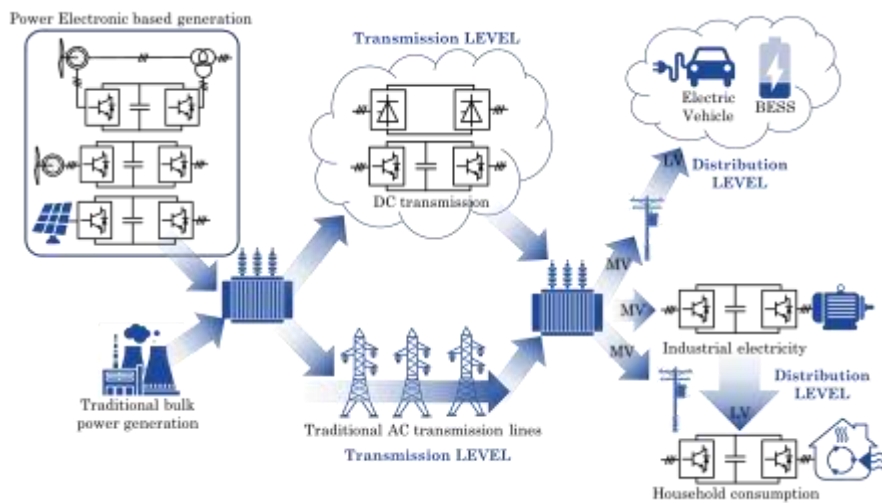

Figure 19: Power electronic converter applications inside modern power systems.

Power electronic converter is a key element enabling the transition to a low carbon power system; as a consequence, it is expected that the penetration of PECs continues increasing in the future. As the technology evolves, the PECs will evolve in three main advances: high power, higher frequency, and lower losses will continue to be invented.

1.7 Current Source Converter (CSC) and Voltage Source Converter (VSC)

The two major types of power electronic converter can be defined in terms of the main electrical variables: (i) voltage source inverter (VSI) and current source inverter (CSI).

The *current source converter* (CSC) uses thyristors, and a large inductor is connected on the DC side; the large inductor is used to maintain the DC current more or less constant (other than a small ripple).

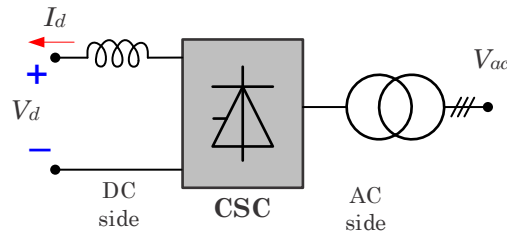

Figure 20: Illustrative example of a current source converter (CSC).

The voltage source converter used fully controllable (turn on/off) power electronic switches allows creating DC voltages voltage is always the same polarity and the current reverses to change the direction of power flow. This type of converters uses a large capacitor on the DC side, thus maintaining the DC voltage more or less constant. The VSC converters use IGBT, GTO and other transistors as power electronic switches.

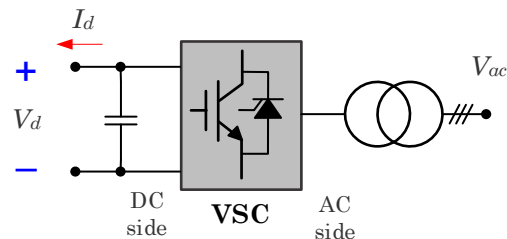

Figure 21: Illustrative example of a voltage source converter (VSC).

The CSC has several advantages:

- The CSC can be made up to very high power, and DC voltage ratings and the thyristors are comparatively robust with a significant transient overload capability.
- The CSC uses thyristors, and as they switch off only when the current through them has dropped to zero, switching losses are low.

On the other hand, VSC has several advantages:

- The VSC can operate at any combination of active and reactive power; the power control is very flexible because of the use of fully controllable power electronic switches.
- The VCS has the ability to operate into a weak grid (low short circuit level) and even black-start an AC network.

The CSC is a mature technology that arrived into the power systems by 1950s, the active power losses caused by the communication process still lower than the VSC a typical converter station power losses are lower than 0.8% compared with 1.1% for the same size installation of VSC. Modern CSCs are able to deliver 12,000 MW and using ultra-high-voltage DC $\pm 1,100$ kV (e.g. Changji to Guquan). On the other hand, the state of the art converters reached a level of ± 525 kV, 1,400 MW (e.g. new Norway-Germany interconnector).

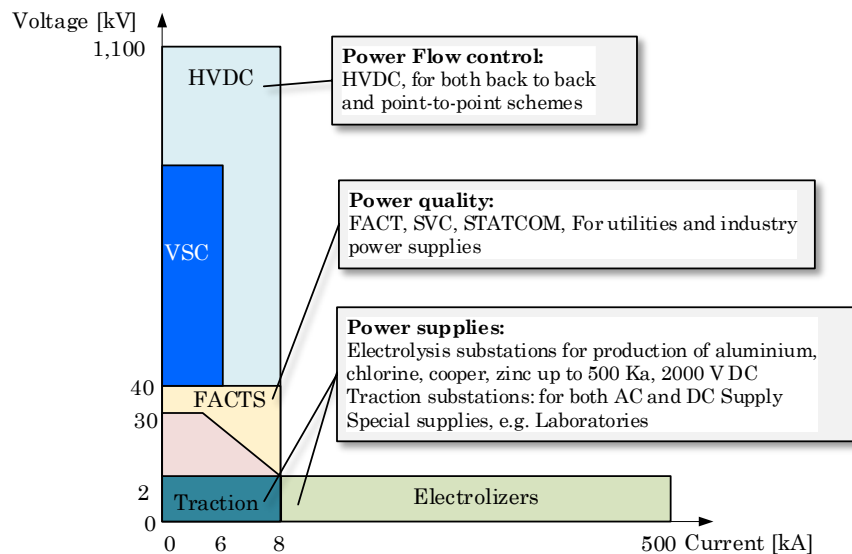

Figure 22: Simplified summary of the power electronic converter application indicating voltage and current indicators.

VSC and CSC have many applications of insider power systems; a very limited summary is shown in **Figure 23**.

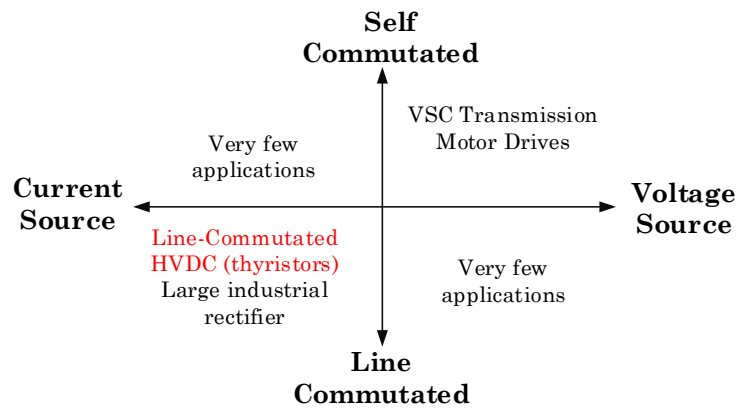

Figure 23: A summary of the main power electronic application depending on the type of power electronic converter (VSC and CSC) and the type of commutation.

Different HVDC power electronic converter topologies have been proposed, built and utilised all over the world. However, the two dominant types are the *line commutated converter* (LCC) and the *voltage source converter* (VSC). **Figure 24** shows a generic point-to-point HVDC link interconnecting two AC power systems. The power converter stations (PEC_1 and PEC_2) can be created using LCC, VSC or combination of them, one of the converter station working as a rectifier and the other as inverter depending on the energy flow between the AC systems.

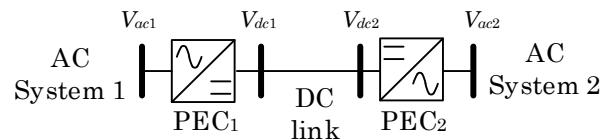

Figure 24: Illustrative point-to-point DC link between two AC power systems.

CSC and VSC have been key enablers on the development of the HVDC systems. HVDC interconnections can be configured in different forms to suit the different desired performance and operational requirements; a non-exhaustive classification includes (for simplicity the figures are created using thyristor-based converters):

Back-to-back: The back-to-back connection is one where both, the inverter and the rectifier, are localised at the same location [6]. The back-to-back connection has

much application at many applications as PV systems, BESS, and full rated power converters. At HVDC applications, back-to-back configuration the rectifier and inverter at the same location usually interconnected via a short DC line of few meters located inside the same environment. The typical application is the separation of two independent power systems (see **Figure 25**). These systems are not synchronised or on a different nominal frequency [7]. An example of back-to-back thyristor-based link installed at the River Canada, the back-to-back converter was rated at 320MW.

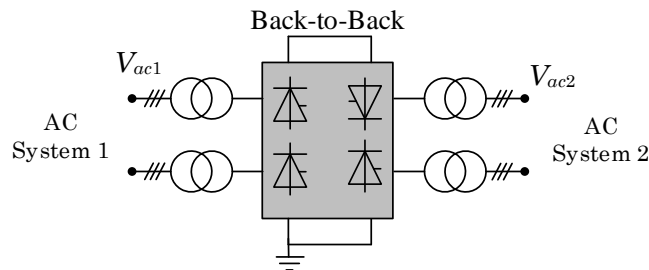

Figure 25: Illustrative diagram of a back-to-back configuration for HVDC.

Monopolar connection: A monopolar link has one conductor at a high DC voltage. The other conductor can use either the ground (see **Figure 26**) or sea as the return path or metallic return wire (see **Figure 27**). Both converters are separated by a single DC pole line, either positive or negative voltage. The ground is used as a current return path. Most submarine cable connections use monopolar systems. Low-voltage electrode lines and sea electrodes to carry the return current in submarine cable crossings.

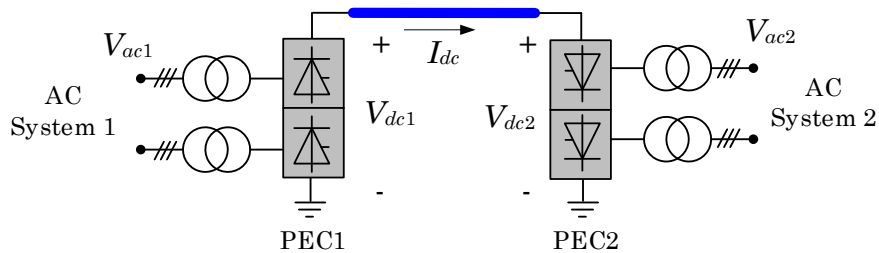

Figure 26: Illustrative diagram of a monopole ground-return configuration for

HVDC.

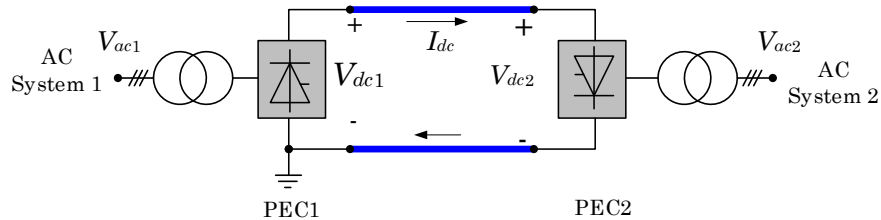

Figure 27: Illustrative diagram of a monopole metallic-return configuration for HVDC.

Homopolar connection: This has two or more DC line of the same polarity connected to the converters (see **Figure 28**). The negative polarity is typically used for less corona and reactive power loss. The physical ground is used as a return path of the currents. A simple glance, the connection works as a monopole when one pole develops a fault; as a consequence, this connection has a improve reliability. The disadvantage of high cost make it unpopular and seldom used.

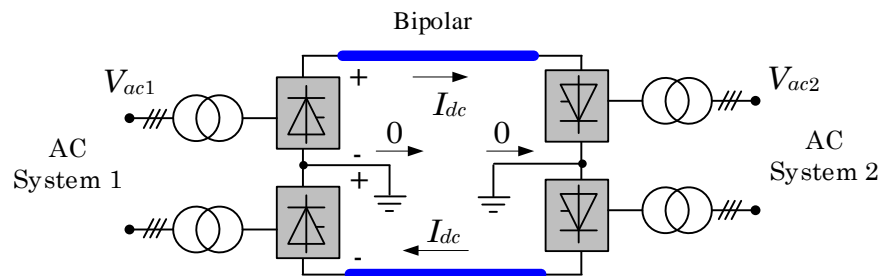

Figure 28: Illustrative diagram of a homopolar configuration for HVDC.

Bipolar connection: The bipolar connection is the most popular method in HVDC interconnection of converters. This connection similar to the homopolar connection, but it has different polarities (see **Figure 29**). In the bipolar connection each pole is independent, that is, it can operate with a single-pole with ground used as a return path.

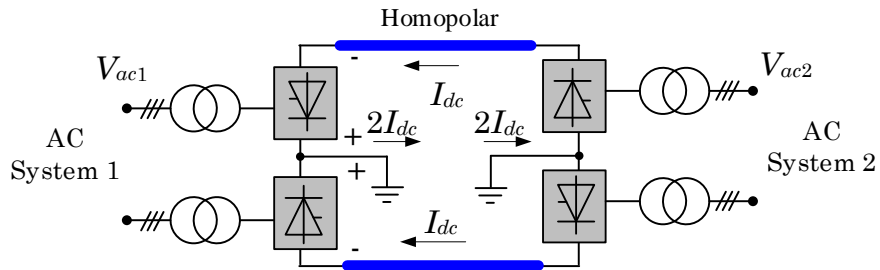

Figure 29: Illustrative diagram of a bipolar configuration for HVDC.

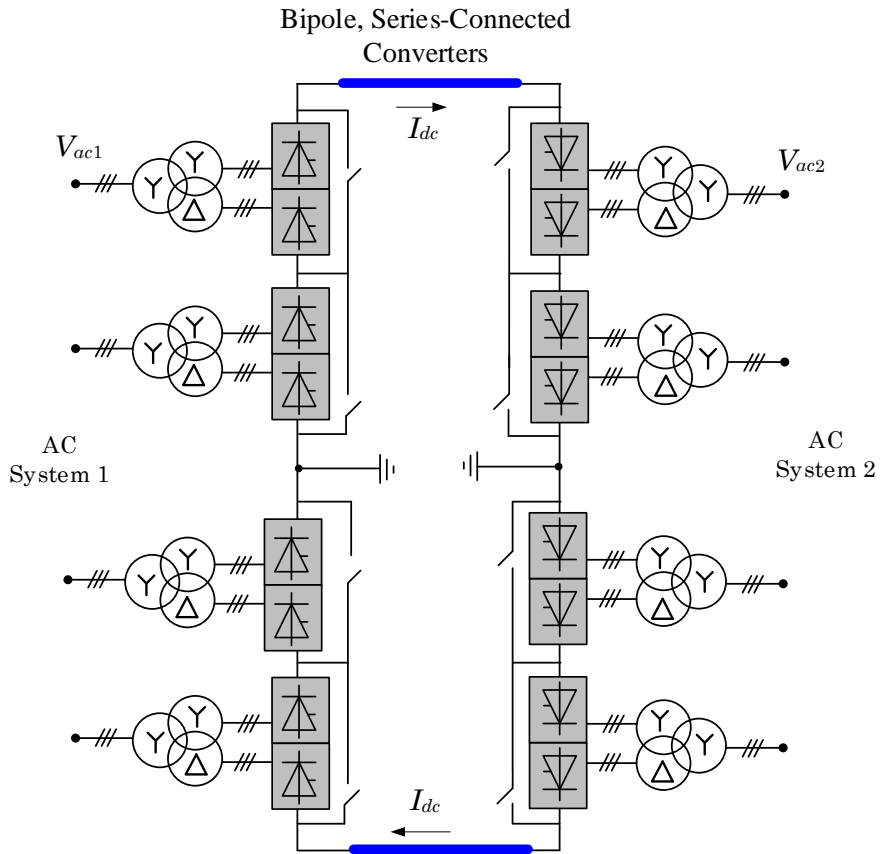

Figure 30: Illustrative diagram of a bipolar, series-connected configuration for HVDC.

Multi-terminal connection: The most recent development in VSC with enhanced operating flexibility is allowing the development of novel connections. The multi-terminal connection has more than two sets of converters operating independently. Each converter can operate as a rectifier or an inverter.

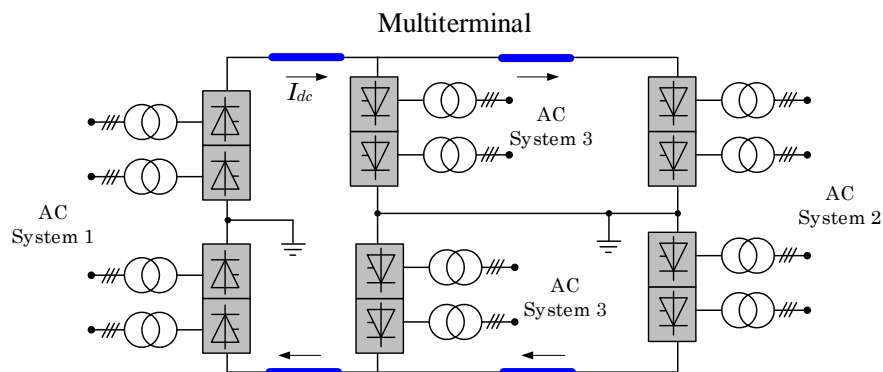

Figure 31: Illustrative diagram of a multi-terminal (three-LCC converter stations) configuration for HVDC.

The HVDC converter stations based on LCC has been dominating by decades in the market. Actual LCC based HVDC has the highest power rating of all HVDC technologies, LCC current rating reaches up to 6,250A and blocking voltage of 10 kV. **Figure 32** shows point-to-point DC-link showing the details of the LCC power electronic converter stations. The power transfer is from AC System 1 to AC System 2, as a consequence, the PEC_1 is working as a rectifier (AC/DC conversion), and PEC_2 is an inverter (DC-AC conversion).

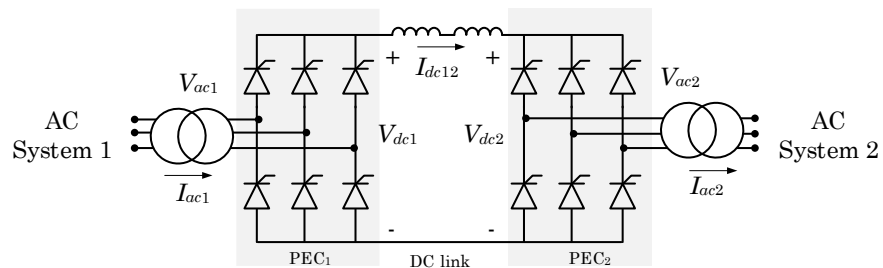

Figure 32: Details of a point-to-point DC-link based on LCC power converter stations.

The main variable of interest in the LCC link is the currents moving through the system; a circuit model can be used to represent the steady-state behaviour. A controlled current source is used to represent the current provided by the power converter; this situation is depicted in the circuit shown in **Figure 33**.

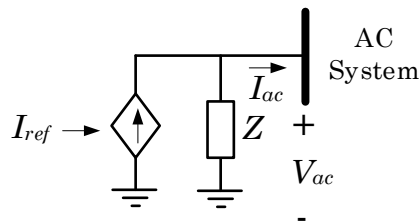

Figure 33: Equivalent circuit representing the AC side of the LCC working as an inverter.

VSC uses fully controllable power electronic switches such as IGBT, GTO, etc. The fully controllable turn on/off of the switches allows the current being switched on and off at any time independent of the AC voltage; this feature is quite attractive because it allows the VSC to create its own AC voltages providing black-start capabilities. This technology was developed in the 1990s with the first project commissioned by ABB, 1997. Today, rated capacity of VSC is still below the LCC, the largest VSC example is the 14,00MW, ± 525 kV Nordlink that interconnects Norway and Germany (distance ~ 623 km).

Figure 34 shows point-to-point DC-link showing the details of the VSC power electronic converter stations, in this case, the PEC_1 is working as a rectifier (AC/DC conversion), and PEC_2 is an inverter (DC-AC conversion).

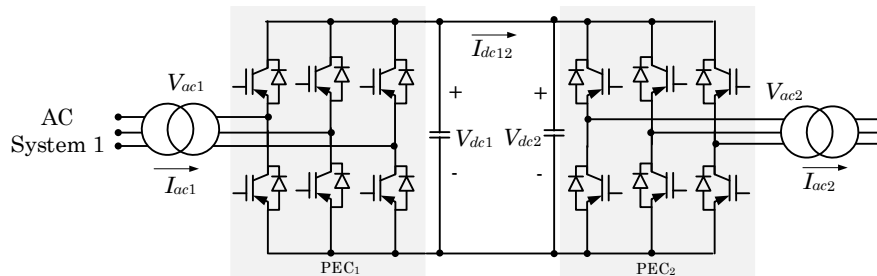

Figure 34: Details of a point-to-point DC-link based on VSC power converter stations.

The main variable of interest when modelling a VSC is the voltage; a circuit model can be used to represent steady-state behaviour. The circuit consists of a controlled voltage source is used to represent the voltage provided by the power converter; this situation is depicted in the circuit shown in **Figure 35**.

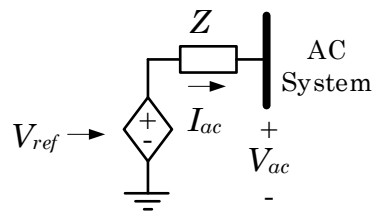

Figure 35: Equivalent circuit representing the AC side of the VSC working as an inverter.

The VSC operates at a high frequency using a pulse width modulation (PWM) techniques which allows simultaneous adjustment of the amplitude ($|V_{VSC}|$) and phase angle (δ_{VSC}) of voltage generated by the converter while keeping the voltage constant.

The PWM, or *pulse-duration modulation* (PDM), is a method of reducing the average power delivered by an electrical signal, by effectively chopping it up into discrete parts.

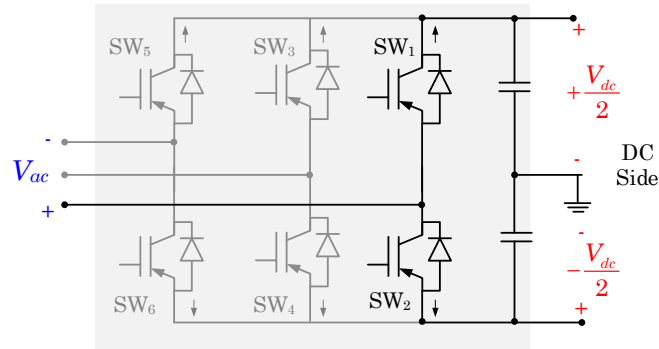

Figure 36: Schematic diagram of a three-phase full-bridge (VSC) inverter.

Ideal PWM inverter output voltage (instantaneous component, blue trace) and its averaged counterpart (fundamental component, red trace) are shown in **Figure 37**.

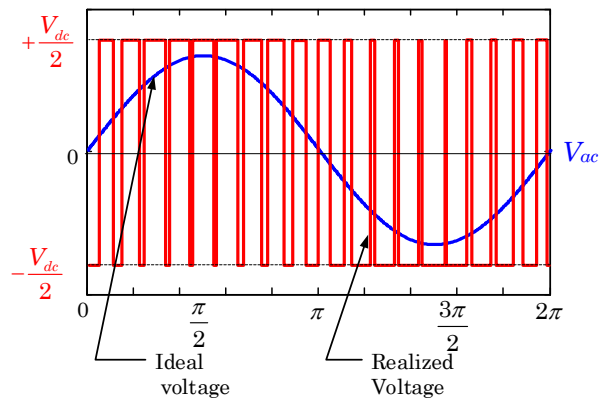
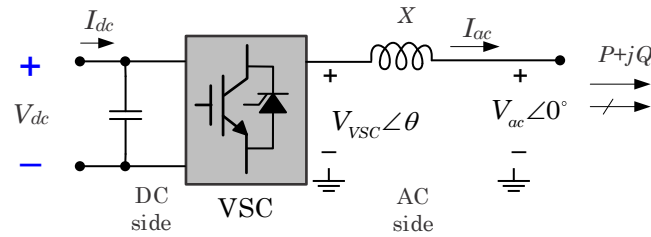

Figure 37: Ideal voltage and average voltage of three-phase full-bridge shown in Figure 36.

Many different types of PWM control technique are available: Single pulse width modulation (Single PWM), Multiple pulse width modulation (MPWM), Sinusoidal pulse width modulation (SPWM), Modified Sinusoidal pulse width modulation (MSPWM), etc. Each of those techniques has advantages and applications a full discussion of them is out the scope of this book. However, the reader must be aware that each technique has a specific set of advantages and disadvantages that make them useful at power systems applications.

The PWM is the most used technique at VSC, it operates at a high frequency, and

it allows simultaneous adjustment of the amplitude ($|V_{VSC}|$) and phase angle (δ_{VSC}) of voltage generated by the converter while keeping the voltage constant (see **Figure 38**).



(a) Schematic diagram of the steady-state operation of a VSC inverter (RMS values depicted)

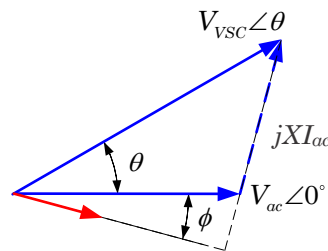

(b) Phasor diagram of the steady-state operation of a VSC inverter

Figure 38: Steady-state operation of a VSC inverter.

The controllability of the VSC provides a very high degree of flexibility, making it possible to control the active (P) and reactive power control (Q) [8]:

$$P = \frac{|V_{ac}| |V_{VSC}|}{X} \sin \theta \quad (1)$$

$$Q = \frac{|V_{ac}| [|V_{VSC}| \cos \theta - |V_{ac}|]}{X} \quad (2)$$

1.8 Power Converter in DIgSILENT PowerFactory

DIgSILENT PowerFactory is equipped with a set of network elements with specific applications for power electronic.

On to the power, electronic devices included in PowerFactory is the model of the

thyristor-based converter, specifically the *6-pulse power converter* with the possibility of operating as *rectifier* or *inverter*. The element *ElmRec*, *ElmRecMono* are designed as configurable devices that allow the simulation of *three-phase diode rectifier* or *three-phase line-commutated rectifier/inverter*; a general overview of the one HVDC converter station (using *ElmRec*, *ElmRecMono*)[9] is shown in **Figure 39**.

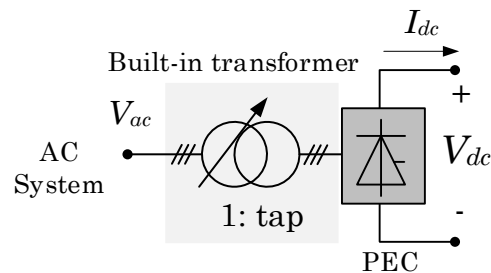

Figure 39: Illustrative schematic of an HVDC converter using *ElmRec*, *ElmRecMono* in DIGSILENT PowerFactory. The model comes with a built-in transformer.

Figure 39 shows a thyristor-based HVDC converter station that can be specified to operate on rectifier or inverter, but the element allows the use of standard full-bridge diode rectifier. In such a case, the bridge is rectifying the three-phase AC voltage to a 6-pulse DC voltage. Diodes are non-controllable power switches as a consequence they can neither be turned-on or turned-off externally, the DC voltage or DC current of the rectifier cannot be controlled.

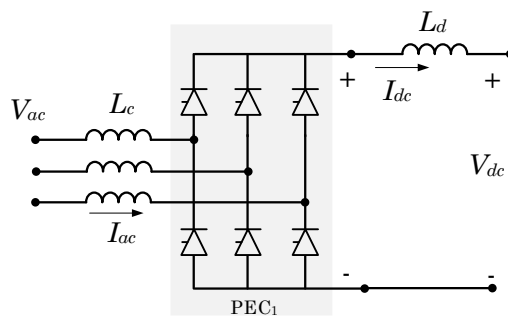

Figure 40: Illustrative schematic the three-phase thyristor bridge used in an HVDC converter using *ElmRec*, *ElmRecMono* in DIgSILENT PowerFactory. The conductance, inductance and the DC reactance are not part of the model.

Figure 40 shows a detailed model of a thyristor-based controlled converter; the model consists of six power thyristors. These power electronic switches can be turned on by an external control signal, but only turned-off when the current flowing through them becomes negative.

Figure 41 shows the voltage waveforms on AC and DC side of a 1 MW, 1 kV, 50 Hz (RMS, line-to-line) 6-pulse power converter based on diodes. The peak value of the signal applied at the AC side is:

$$V_p = \frac{\sqrt{2}}{\sqrt{3}} V_{rms} = \frac{\sqrt{2}}{\sqrt{3}} (1000V) \cong 816.496V \quad (3)$$

The DC output voltage (V_o) is obtained as the mean value of the direct-output voltage:

$$V_o = V_{rms} \frac{3}{\sqrt{2\pi}} = (1000V) \frac{3}{\sqrt{2\pi}} \cong 675.237V \quad (4)$$

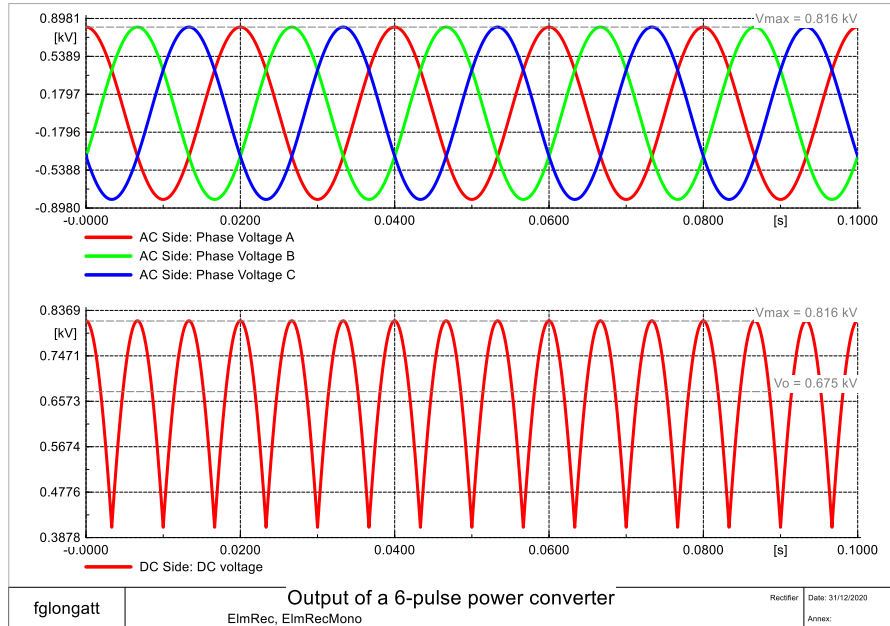

Figure 41: Illustrative example of AC and DC side oltage waveform vof a three-phase thyristor bridge.

Thyristor based power converter allows the controllability of the average output voltage by controlling the fining angle. **Figure 42** shows a comparison of waveform taken from the DC side of a thyristor-based controlled-rectifier considering a firing angle $\alpha = 35^\circ$ and $\alpha = 75^\circ$, as expected the average mean value of the direct-output voltage depends on the cosine of the firing angle α :

$$\hat{V}_0 = V_{rms} \frac{3}{\sqrt{2\pi}} \cos \alpha = V_0 \cos \alpha \quad (5)$$

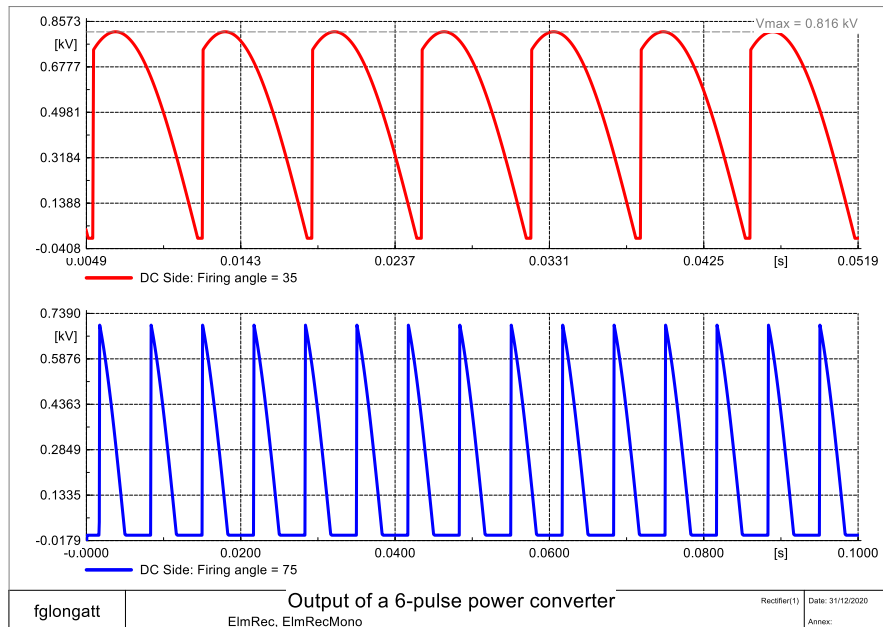

Figure 42: Illustrative example of AC and DC side voltage of a three-phase thyristor bridge.

DIgSILENT PowerFactory is well-equipped with several examples where the user can try several pre-built projects with specific power system studies. One of those examples was implemented in DIgSILENT PowerFactory version 15.0 and is contained in the file "HVDC-Example.pfd". Now, the example is an integral part of the examples in version 2020, and it is a classical thyristor-based HVDC link¹ used for assessing the performance of the system by using power flow and time-domain simulation (RMS and EMT) [9]. The reader is invited to open DIgSILENT

¹ M. Szechtman, T. Wess, and C. Thio, "A benchmark model for HVDC system studies," in International Conference on AC and DC Power Transmission. IET, 1991, pp. 374–378.

PowerFactory, and find the aforementioned example, read the literature provided by DIgSILENT and conduct the proposed simulations.

The modern PECs take advantage of the fully controllable power electronic switches, such as IGBT and GTO, and the use of the VSC has escalated for many power system applications up to HVDC systems. DIgSILENT PowerFactory includes the element *ElmVsc* and *ElmVscmono*; both of them are able to simulate VSC.

The element *ElmVsc* and *ElmVscmono* are based on the use of PWM to operate the fully commutable power electronic switches systematically. The model has the option to be configured as a self-commutated, *voltage-source AC/DC two-level converter* and a *modular multilevel converter (MMC)*. For those converter types, DIgSILENT PowerFactory offers two types of connections, the so-called *ElmVsc* providing two ports of connection at the DC side, on the other hand, the *ElmVscmono* is designed to offer a single DC port at the return is assumed to be by the ground path.

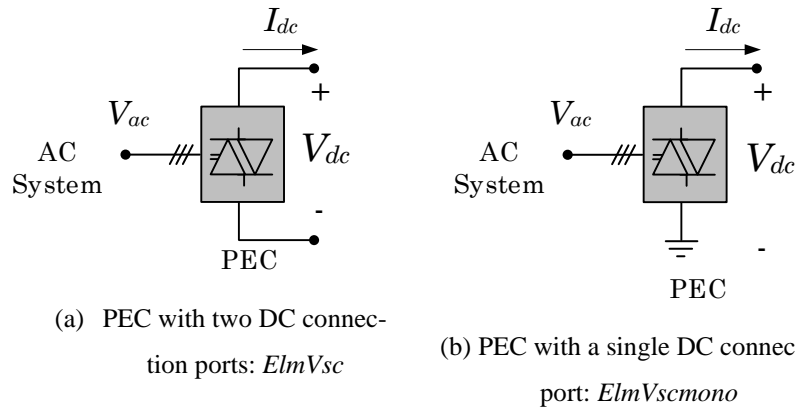

Figure 43: Illustrative examples of the PWM based PEC available in DIgSILENT PowerFactory.

The internal topology of the PEC is easily configurable, allowing the presentation of the *two-level converter*, and *half-bridge* and *full-bridge MMC*.

The two-level converter is the simplest type of three-phase VSC and can be thought

of as a six pulse bridge in which the thyristors have been replaced by power electronic switches with turn-off capability with inverse-parallel diodes, and the DC smoothing reactors have been replaced by DC smoothing capacitors (see **Figure 44**).

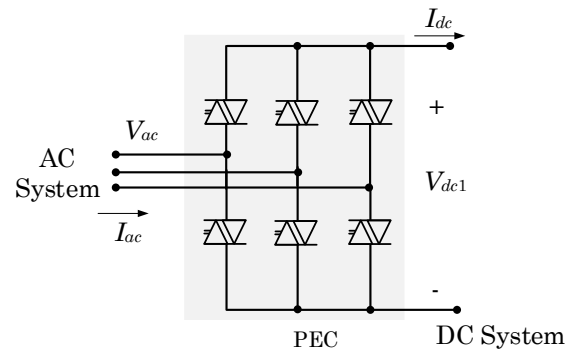

Figure 44: Illustrative circuit of two-level converter implementation in DigSILENT PowerFactory (*ElmVsc* and *ElmVscmono*).

PowerFactory includes the implementation of MMC based PECs, to do so two submodules types of internal topologies are available: half-bridge and full-bridge (see **Figure 45**).

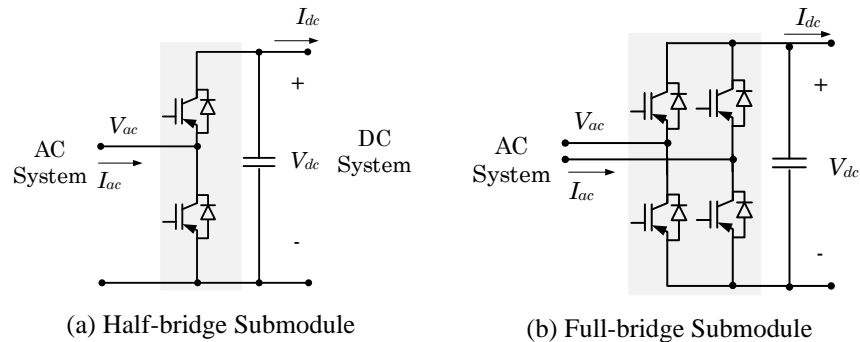

Figure 45: Illustrative circuit of half-bridge and full-bridge MMC implementation in DigSILENT PowerFactory (*ElmVsc* and *ElmVscmono*).

The MMC configuration enables the uses of half-bridge and full-bridge topologies at each *submodule* (SM), DigSILENT PowerFactory allows a configuration of SM

creating arms and legs, see **Figure 46**.

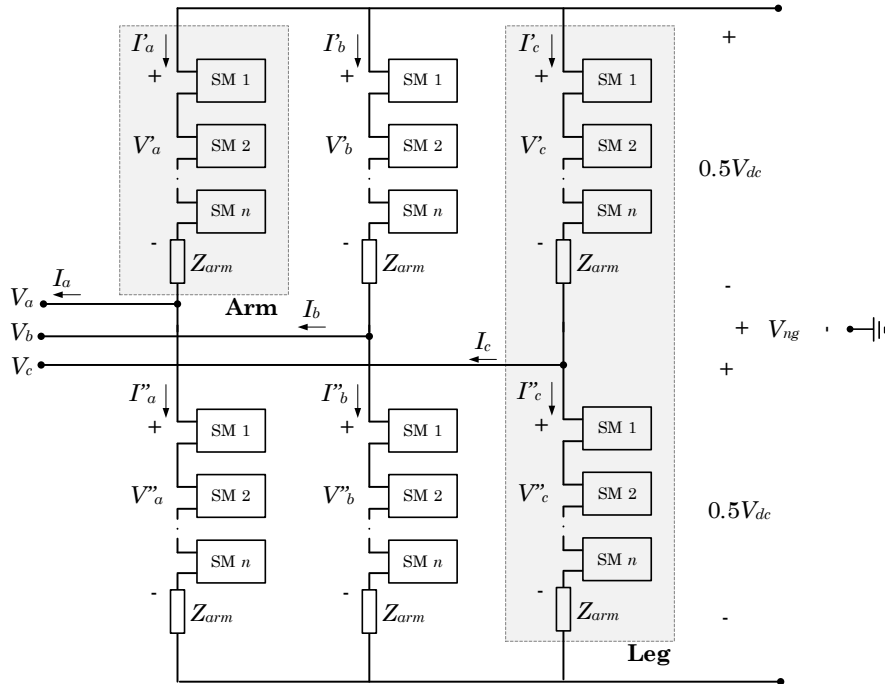

Figure 46: Illustrative circuit of half-bridge and full-bridge MMC implementation in DIgSILENT PowerFactory (*ElmVsc* and *ElmVscmono*) [9].

DIgSILENT PowerFactory includes several examples one of them is titled “HVDC Connected Offshore Wind Farm”. The examples consist of a VSC-HVDC link for a 400MW offshore wind farm consisting of DFIG wind turbines. The model is very well developed, including several control loops and also a chopper controller to use the ElmValve (the reader is highly encouraged to check those models).

The example is very comprehensive, including short-circuit analysis and RMS and EMT simulations.

1.9 Modern Tendencies in Power Electronic Applications in power systems

The modern power system is in a very important transition, moving from a synchronous machine-based system towards an inverter-dominated system, with large-scale penetration of low carbon technologies, including renewable energy sources (RESs) like wind and PVs.

Traditional *synchronous machines* (SM) are very different from the model PECs. A traditional generation unit using SM directly connected to the grid can be divided into two main areas: the energy conversion process where the electro-mechanical interactions take place, it is basically dictated by the magnetic coupling between the rotor at the stator of the SM; and the generation control process where at least two basic controllers are considered: frequency control and AC voltage control (see **Figure 47**). One very important aspect of the electro-mechanical process is the fact there is a natural energy storage system in the SM, it comes from the kinetic energy stored in the rotating mass: flywheel, rotor and turbine (total H).

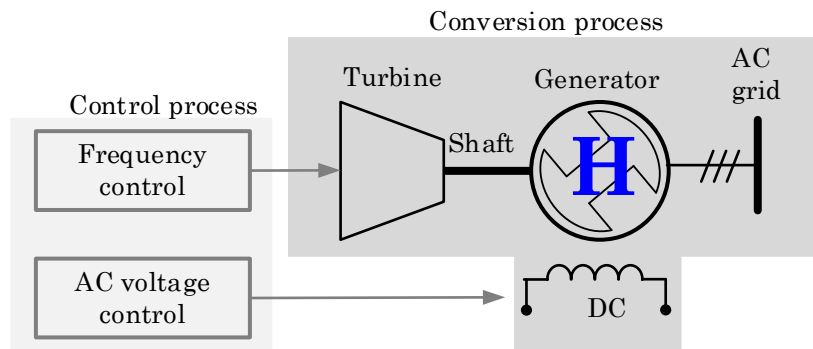

Figure 47: Illustrative scheme of the energy conversion, energy storage and controllers of a synchronous machine.

The increasing penetration of low carbon technologies is motivating the growing integration of PECs [10]. The PEC is basically an energy conversion system, where the interconnection to the grid is based on a DC-AC converter, the energy conversion is done through the power electronic switches. It is evident the PEC alone is not able to generate electricity; in fact, the PEC requires a primary energy

source and energy storage in order to look similar to a traditional synchronous generator. From the control point of view, the PEC has intensive requirements, the power electronic switches work a very high frequency as a consequence high-frequency signal must be systematically produced to control the PEC appropriately, the typical control is based on the use of the two-axis theory, the d -axis and q -axis components of the pulse-width modulation (PWM) control, which directly actuate the d -axis and q -axis components of the AC current [11].

From the power electronic and machine theory, it is clear one of these components is typically utilised to regulate the grid-side AC voltage. On the other hand, depending on the configuration and the converter topology, the other component can be used, for example, to regulate the DC voltage or current flowing through the converter; this is the typical case of the PV systems and fully related to converter variable speed wind turbines. Lastly, the active power injection and the energy balance across the converter's DC storage (DC side capacitor) are regulated through the control of the energy source connected to the converter.

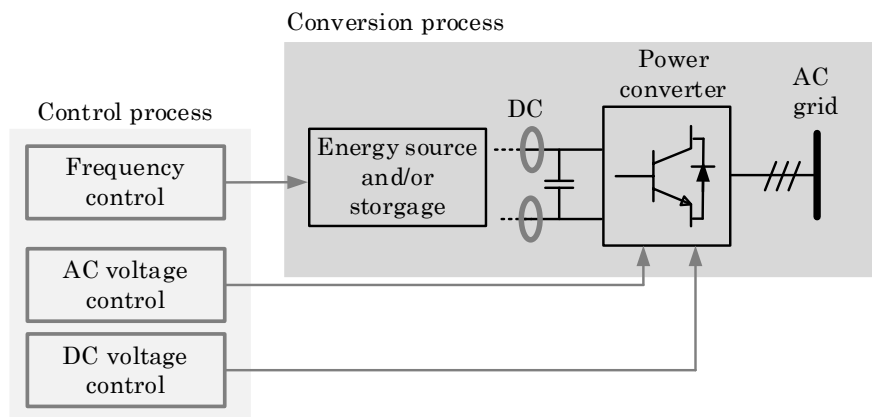

Figure 48: Illustrative scheme of the energy conversion, energy storage and controllers of PEC.

The two-axis theory has their fundamentals form the analysis of SM, and it is something very natural to thing and understands, however, when the dq -axis theory is applied to the control of PEC, it requires an angle reference for this dq -frame.

Without any generalisation, two taxonomy of control loops have been formulated for frequency control: *grid following* (reference angle obtained from a PLL) and *grid forming converters*.

1.10 Conclusion

The most recent advancements in the power electronics industry made the integration of low carbon technologies be a reliable alternative to substitute the technologies base on SM, and consequently, the integration of VSC based generation units into the transmission system has been increased. The fast dynamic response of power electronic switches provides the solar PEC-based technologies with a quick response that enables these resources to contribute to system stability. However, there are major changes to the way to supply and use energy; building a smarter grid lies at heart to these changes: (i) The significant increases in electricity generation from intermittent/highly variable renewable resource, (ii) The increase of stressing/narrowly conditions on the transmission system, (iii) Massive decoupling between generation/load caused by PEC-based system, and several other features expected into the future electricity networks will negatively affect the system security.

The core of the energy transition toward a reduced low carbon footprint in the electric sector is the change in generation technology; from fossil fuel-based thermal generation to converter interfaced renewable generation. However, a very important issue is rising; the power system is gradually losing synchronous machines (SMs). The installed capacity is increasing because more generation is being installed, but the generation mix is changing, the renewable generation connected via PEC is increasing at the time that many fossil-based and nuclear power plants are decommissioned. The power system is losing synchronous machines with all the excellent properties of them, and they are substitute with very sensible and fragile PEC. The SM provides very useful services and characteristics in natural from, kinetic energy storage, overloading capacity, simple and reliable control mechanisms. On the other hand, power engineers

have tried to make the PECs to behave like SM, as a consequence multiple control loops to mimics SM has been developed (e.g. inertial control, droop control etc.), but one of the main disadvantages of the PECs is that they require measurements, signal processing and so many other things that they are not able to naturally do like SM does. As a consequence, the way of PEC being integrated into the power systems must change. More research and development are required for the integration of PEC, and exciting times are coming.

1.11 References

- [1] F. Gonzalez-Longatt, "Frequency Control and Inertial Response Schemes for the Future Power Networks," in *Large Scale Renewable Power Generation*, J. Hossain and A. Mahmud, Eds. Springer Singapore, 2014, pp. 193–231.
- [2] F. Sanchez, J. Cayenne, F. Gonzalez-Longatt, and J. L. Rueda, "Controller to enable the enhanced frequency response services from a multi-electrical energy storage system," *IET Gener. Transm. Distrib.*, vol. 13, no. 2, pp. 258–265, Jan. 2019.
- [3] H. Chamorro, F. Gonzalez-Longatt, and V. K. Sood, "Dynamic Measurements of the Wind Power Impact on Power System Inertia and Stability," in *International Conference on Innovative Smart Grid Technologies (ISGT Asia 2018)*, 2018.
- [4] E. C. Dos Santos and E. R. Cabral da Silva, *Advanced Power Electronic Converters: PWM Converter processing AC voltages*. Hoboken, NJ, USA: John Wiley & Sons, Inc, 2014.
- [5] V. T. Ranganathan, N. Mohan, and T. M. Underland, *Power electronics: Converters, Applications and Design*, vol. 33, no. 5. 2008.
- [6] V. K. Sood, *HVDC and FACTS controllers: applications of static converters in power systems*. Boston; London: Kluwer Academic Publishers, 2004.
- [7] J. L. Dirk Van Hertem, Oriol Gomiz-Bellmunt, *HVDC GRIDS: For*

Offshore and Supergrid of the Future, no. c. Hoboken, New Jersey: JohnWiley & Sons, Inc., 2016.

- [8] H. R. Chamorro, A. C. Sanchez, A. Pantoja, I. Zelinka, F. Gonzalez-Longatt, and V. K. Sood, "A network control system for hydro plants to counteract the non-synchronous generation integration," *Int. J. Electr. Power Energy Syst.*, vol. 105, pp. 404–419, Feb. 2019.
- [9] DlgSILENT, "User's Manual DlgSILENT PowerFactory 2020." Gomaringen, Germany, 2019.
- [10] A. Peña Asensio, F. Gonzalez-Longatt, S. Arnaltes, and J. L. Rodríguez-Amenedo, "Analysis of the Converter Synchronizing Method for the Contribution of Battery Energy Storage Systems to Inertia Emulation," *Energies*, vol. 13, no. 6, p. 1478, Mar. 2020.
- [11] H. Chamorro, F. Gonzalez, K. Rouzbehi, R. Sevilla, H. Chavez, and V. Sood, "Innovative Primary Frequency Control in Low-Inertia Power Systems Based on Wide-Area RoCoF Sharing," *IET Energy Syst. Integr.*, Feb. 2020.