

FMH606 Master's Thesis 2020

Process Technology

Utilization of excess heat from data centers

Mohammad Sharfuddin

Faculty of Technology, Natural sciences and Maritime Sciences
Campus Porsgrunn

Course: FMH606 Master's Thesis, 2020

Title: Utilization of excess heat from data centers.

Number of pages: 34

Keywords: Data center, heat recovery, district heating, heat pump, Aspen HYSYS.

Student: Mohammad Sharfuddin

Supervisor: Lars Erik Øi

External partner:

Availability: Open

Summary:

Digitalization has influenced the rapid growth of data centers around the world. The advancement of IT and telecommunication also played a vital role in this expansion of data centers. Data centers facilitate the storage and access of data when required. Electric power is the main energy input and heat is the main energy output from the data center. This work is about the utilization of the excess heat which is the by-product of data center operation. To connect the heat from data centers to a district heating network, a heat pump might be necessary to increase the temperature of the heat. The economic potential for different conditions and different heat recovery solutions are evaluated.

Simulations and economical optimization at different conditions in Aspen HYSYS were carried out. Especially three alternatives were evaluated. The first is an alternative without a heat pump in which the cooling water leaves the data center at 80 °C and enters the district heat network at 70 °C. The second is an alternative with a slight temperature increase in the heat pump. The cooling water temperature from the data center is 65 °C and the temperature to the district heat system is 70 °C. The third is an alternative with a higher temperature increase in the heat pump. The cooling water temperature from the data center is 65 °C and the temperature to the district heat system is 80 °C. The COP (Coefficient of Performance) in a heat pump for these alternatives were calculated using the refrigerant R-22 in the simulation program Aspen HYSYS. The estimated economic potential for each alternative was calculated by estimated values on electricity cost and district heat price. In one alternative, the electricity cost was specified to 0.1 EUR/kWh, and the district heat price was specified to 0.05 EUR/kWh. For the alternatives using heat pumps, the capital cost was estimated assuming that the heat pump investment was dominating.

The COPs for the two heat pump alternatives were calculated to be 8.66 and 5.4, respectively. The economy for a large data center facility with recovered waste heat of 200 GWh/year was calculated for 10 years. For the specified conditions, the net present value was calculated to be large and positive for all the alternatives. As expected, the most economical alternative was without a heat pump, and the most economical heat pump was the one with the highest COP. Sensitivity calculations were performed to show dependencies of temperatures, district heating price, electricity cost, heat pump cost, COP, and pipeline cost. Pipeline cost is very much dependent on the length and the local conditions for which it was not possible to make a reasonable estimation.

The calculations show that there is a large potential in using waste heat from data centers for district heating.

Preface

I would like to express my profound gratitude to Prof. Lars Erik Øi for his continuous guidance, support, and, valuable direction through the thesis work. His door was always open for me. Because of the Covid-19 situation, it was difficult to carry out the research work, but my supervisor always motivated me to handle the situation.

I would like to appreciate the support of USN management and administration for providing me immense facilities, to feel like at home at USN.

Last but not least, I would express my heartfelt gratitude to my parents and wife without whom it would not be possible to finish the thesis work.

Porsgrunn, 29.05.2020

Mohammad Sharfuddin

Contents

1	Introduction	9
1.1	Background	9
1.2	Objectives	9
1.3	Structure of the report.....	10
2	Literature review	11
2.1	General literature on energy recovery from data centers.....	11
2.2	Possible temperatures in cooling principle in data centers	14
3	Process Description	16
3.1	Air-cooled systems.....	16
3.2	Liquid-cooled systems	17
3.3	Description of heat pump process.....	18
4	Material and energy balance calculation	21
4.1	Simulation setup in Aspen HYSYS.	21
4.2	The energy required calculation from Aspen HYSYS	21
4.2.1	<i>Total energy requirement calculation.....</i>	<i>21</i>
4.2.2	<i>Calculation of COP for heat pump.....</i>	<i>24</i>
5	Cost calculation	25
5.1	Energy cost calculation.....	25
5.2	Investment cost calculation	26
5.3	Evaluation of pipeline cost.....	26
6	Discussion.....	27
6.1	Based on Aspen HYSYS calculation.....	27
6.2	Economic potential analysis.....	27
7	Recommendation for future work.....	29
8	Conclusion	30

List of Figures

Figure 2.1: A schematic diagram of data center waste heat utilization technique in a coal power plant Rankine cycle [4].....	11
Figure 2.2: A schematic diagram of a simple absorption refrigeration system run by the waste heat of data center [4].....	12
Figure 2.3: Schematic diagram of an organic Rankine cycle [4].....	13
Figure 2.4: Schematic diagram of a three-stage MED with the first stage powered by data center waste heat [4].....	13
Figure 2.5: ASHRAE temperature ranges for data centers [6].....	15
Figure 3.1: Schematic diagram of a liquid-cooled system [3].....	18
Figure 3.2: Schematic diagram of a heat pump's mechanical compression cycle [23].....	19
Figure 4.1: Model representation of the DC heat recovery process via heat pump in Aspen HYSYS	22
Figure 6.1: COP of pump versus economic potential value	27

List of Tables

Table 4.1: Aspen HYSYS input condition for alternative 1	21
Table 4.2: Aspen HYSYS input condition for alternative 2.....	21
Table 4.3: Results of material and energy balance achieved from Aspen HYSYS for alternative 1	22
Table 4.4: Results of material and energy balance achieved from Aspen HYSYS for alternative 2	23

Nomenclature

Abbreviations	Explanations
IT	Information Technology
DC	Data Center
DH	District Heating
CRAC	Computer Room Air Conditioning
ORC	Organic Rankine Cycle
MED	Multiple-effect Distillation
ASHRAE	American Society of Heating, Refrigerating and Air conditioning Engineers
CPU	Center Processing Unit
DIMM	Dual In-line Memory Module
COP	Coefficient of Performance

1 Introduction

Data centers have become an indispensable part of the modern digitalized world. Digitalization demands the storage of constantly and rapidly expanding data around the globe, for which the number of data centers is ever-increasing. Apart from digitalization, speedy wireless networks, growing demand for cloud computing have added the crying needs of data centers. The U.S. Environment Protection Agency defines a data center as:

“Primarily electronic equipment used for data processing (servers), data storage (storage equipment), and communications (network equipment). Collectively, these equipment processes, stores, and transmits digital information”[1].

Data centers are run by electricity and the functioning of different equipment release heat. So, all the electricity input is converted to heat. Studies show that the electricity requirement for data center has increased from about 1.3% of the world’s total electricity consumption in 2010 to 2% in 2018 and with this pace, it will reach up to 13% in 2030 [2].

However, the energy source which is still dependent the fossil fuels are gradually decreasing because of the ever-growing consumption. So, the dire need for renewable energy sources is beyond description. The rejected or output heat from data centers could be a useful source of renewable energy. So, the waste heat utilization from data centers has become one of the prime researches for the scientists and data center operator to make data centers energy efficient and economically sound.

1.1 Background

Data centers reject a vast amount of heat which is the conversion of electricity. For the proper and reliable functioning of the data center cooling down of different IT equipment is essential. 40% of the total energy consumption in a DC can be spent in the cooling system [3]. Moreover, excess or rejected heat from a DC can be regarded as lost energy. To make data centers more energy-efficient these lost energies should be utilized. The utilization will be economically profitable also. Furthermore, the cold climate of Nordic countries makes it easy for data centers to provide cooling energy. Besides, the high demand for heat in these countries makes it more convenient to utilize the waste heat. Thus, the necessity of waste heat utilization from data centers arises and this project can serve the purpose to some extent. The thesis will also focus on the possible utilization of waste heat using a heat pump in the district heating facility.

1.2 Objectives

The prime goal of this Master thesis is to utilize excess heat from data centers. Achieving the goal required five main objectives. They are as following:

1. Literature search on cooling principles in computers. Of special interest is to find maximum or optimum temperature on cooling air or cooling water.
2. Process description of cooling processes for a large data center. One case should be for traditional cooling technology, and another should be a case with a high outlet temperature.

3. Calculation of a material and energy balance of the cooling process for at least one large data center. Also, the calculation of the economic potential for specific energy recovery solutions.
4. Evaluations of possible ways to utilize waste heat from a data center. The possibility of district heating should be evaluated. Possibilities including heat pumps and power production should also be evaluated.
5. Simulations and economical optimization at different conditions in Aspen HYSYS.

The detailed task description of the thesis is attached in Appendix A.

1.3 Structure of the report

This thesis consists of eight main chapters. Chapter 1 gives an introduction about the waste heat utilization from data centers, the relative background, and the objectives of the thesis. Chapter 2 interprets the literature study of the energy recovery and possible temperatures in the cooling principle of data centers. Chapter 3 presents the process description of the cooling principles used in data centers along with the process of the heat pump. Chapter 4 represent the necessary material and energy balance calculation. Chapter 5 is developed for cost calculation. Chapter 6 and Chapter 7 gives the discussion and future recommendations. Chapter 8 concludes the thesis.

2 Literature review

This literature review part interprets the studies on the probable energy recovery ways from data centers and possible temperatures in cooling processes in data centers.

2.1 General literature on energy recovery from data centers

Ebrahimi et al. [4] investigated different waste heat recovery technologies from the data center. They suggested that district heating is a common low-quality waste heat recovery technique which is also economically and ecologically sound. Liquid-cooled servers are more compatible with the higher waste recovery temperatures. Liquid-cooled servers can provide waste heat of up to 50-60°C that can be applied to district heating over a long area. This waste heat recovery technique is economically profitable as it can earn a revenue stream for data center operators.

The next option found in [4] was the heating of water in a thermal Rankine cycle. The waste heat cannot fully replace the boiler but can be used to preheat boiler feedwater. So, the consumption of fossil fuel and pollution can be decreased to some extent. Moreover, they suggested on-chip two-phase cooled data centers to utilize most of this technology. The sale of heat to the power plant and carbon offsets can produce substantial income. A schematic of the technology is represented in Figure 2.1.

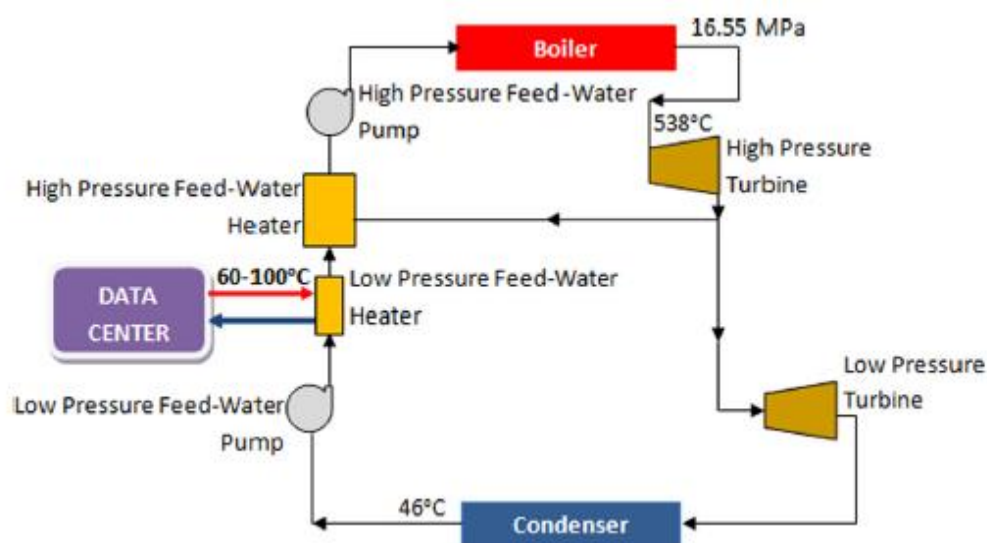

Figure 2.1: A schematic diagram of data center waste heat utilization technique in a coal power plant Rankine cycle [4].

Absorption cooling is another choice for utilizing data center waste heat as studied by Ebrahimi et al. [4]. Absorption refrigeration systems can function with generator temperatures of 70-90°C which could be supplied by the waste heat from a water-cooled and two-phase cooled data center. An air-cooled data center is not viable for the technology. This technique can

minimize the load on data center CRAC systems by producing chilled water for cooling and thus become economically profitable. The concept of the system is depicted in Figure 2.2.

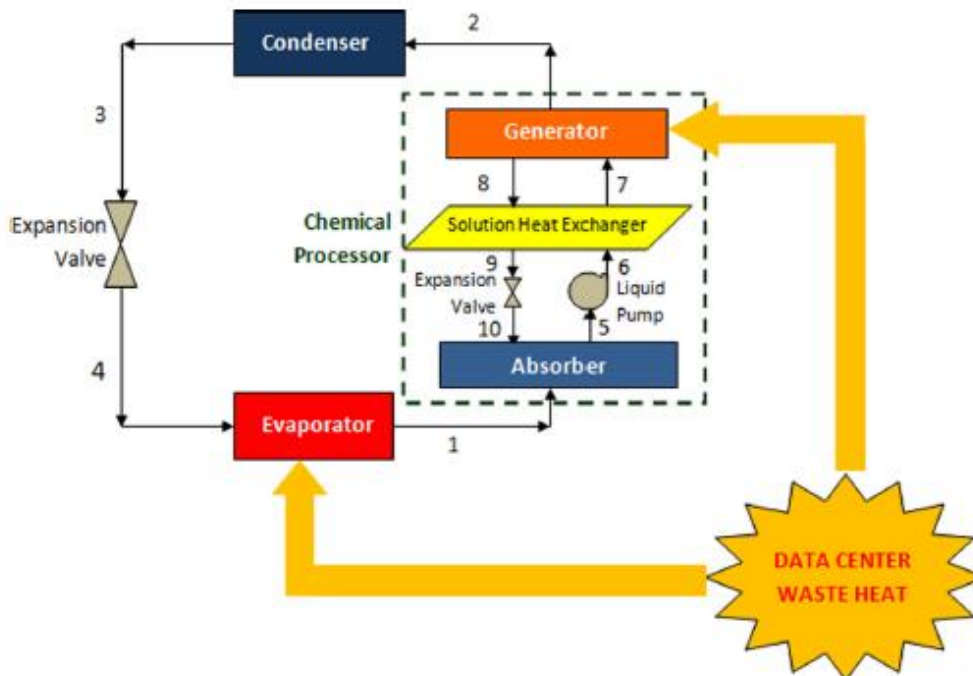

Figure 2.2: A schematic diagram of a simple absorption refrigeration system run by the waste heat of data center [4].

Organic Rankine cycle (ORC) is one of the most suitable options through which electricity can be directly generated from data center waste heat, as suggested by Ebrahimi et al. [4]. The working principle of the organic Rankine cycle is almost the same as the steam Rankine cycle except for the working fluid which has comparatively lower boiling points. As a result, the lower boiling points enable the waste heat of the data center to serve as the heat source. The temperature needed to generate power employing the organic Rankine cycle is 65°C and higher, which can be provided by the waste heat stream from water-cooled or two-phase cooled data centers. Adding a secondary heat source, air-cooled data center can also serve the purpose. Figure 2.3 portrays the organic Rankine cycle with basic components. The main advantage of this technology is the production of on-site electricity and no extra space is required.

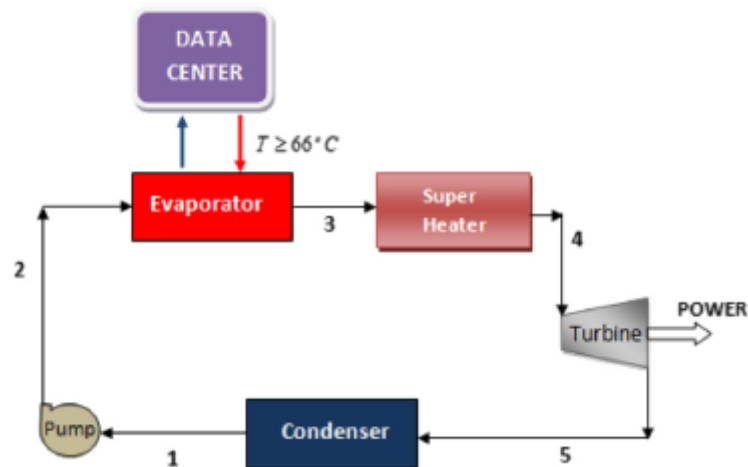

Figure 2.3: Schematic diagram of an organic Rankine cycle [4].

Furthermore, Ebrahimi et al. [4] found that waste heat from the data center can be utilized in multiple-effect distillation (MED) for producing clean water from seawater. Multistage MED clean water production system needs waste heat of temperature 75°C and higher. The use of waste heat from the data center in clean water production gives the advantage of probable removal of the need for the chiller to proper heat extraction during the MED process. A traditional configuration of the MED system is represented in Figure 2.4.

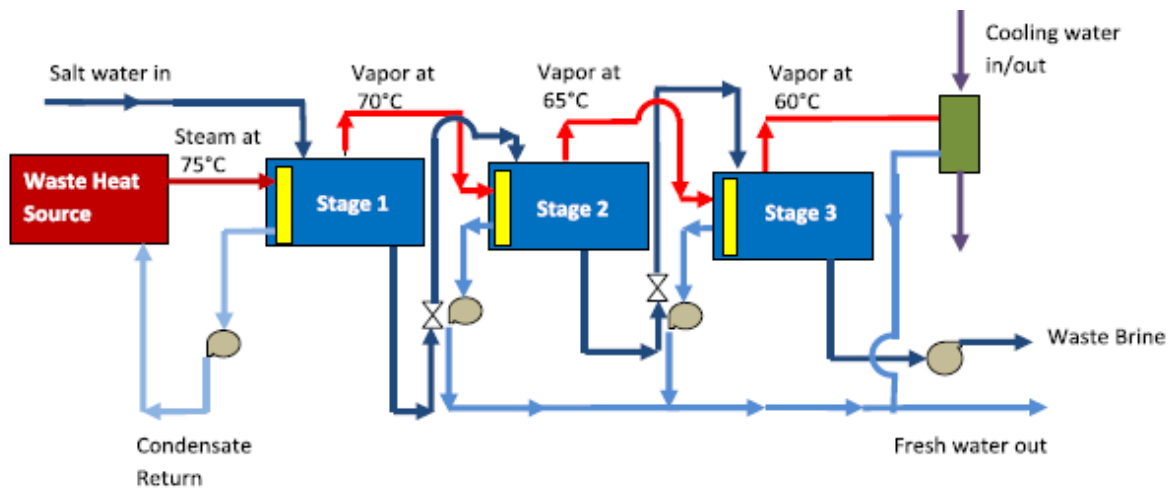

Figure 2.4: Schematic diagram of a three-stage MED with the first stage powered by data center waste heat [4].

Ebrahimi et al. [4] also proposed that direct power generation like piezoelectric and thermoelectric, biomass co-location are the possible techniques that can be useful to utilize the low-grade waste heat from data centers.

Oltmanns et al. [2] Proposed a new cooling concept which TU Darmstadt will employ in the next generation of the current air-cooled servers with water-cooled rear doors. The new data center will use direct hot-water cooling for the high-performance computer, providing heat at 45°C. The waste heat will be utilized for heating the university's campus Lichtwiese. They suggested two ideas, either heat integration in the return line of the district heating network or utilizing it locally in buildings situated near the data center. The project showed that 20-50% of the waste heat rejected by the high-performance computer can be utilized in the heating sector. A significant reduction of CO₂ emission can also be achieved through the project.

Oró et al. [5] studied a liquid-cooled on-chip server numerically for a case study of utilizing the waste heat for an indoor swimming pool heating. For the most suitable solution, the data center operator decreases its operational costs and produces surplus income by selling the excess heat, obtaining a net present value after 15 years of 330,000 €. Besides the operational cost of the indoor swimming pool was reduced by 18%. The case study was implemented for the assessment of Barcelona's indoor swimming pools.

2.2 Possible temperatures in cooling principle in data centers

For the efficient and proper utilization of excess heat from the data centers determining the temperature of the cooling system is not only very essential but also very sensitive. Depending on the temperature range the quality of the heat will be evaluated. The investigation is not a very easy task rather it has been a matter of argument.

ASHRAE Technical Committee 9.9 has done a significant job to determine the favorable environment and temperature range for data centers. This is a common thermal guideline. In [6] ASHRAE recommended that the data center's equipment should maintain the temperature range between 18°C and 27°C to fit the manufacturer's provided criteria. The Technical Committee also classified the data center based on their temperature range. For the A1 data center, the temperature range was 15°C to 32°C, for the A2 category the range was set to 10°C to 35°C. For class A3 and A4 data center they increased the temperature range by 5°C to 40°C and 5°C to 45°C, respectively. The classification and temperature guideline is represented in Figure 2.5.

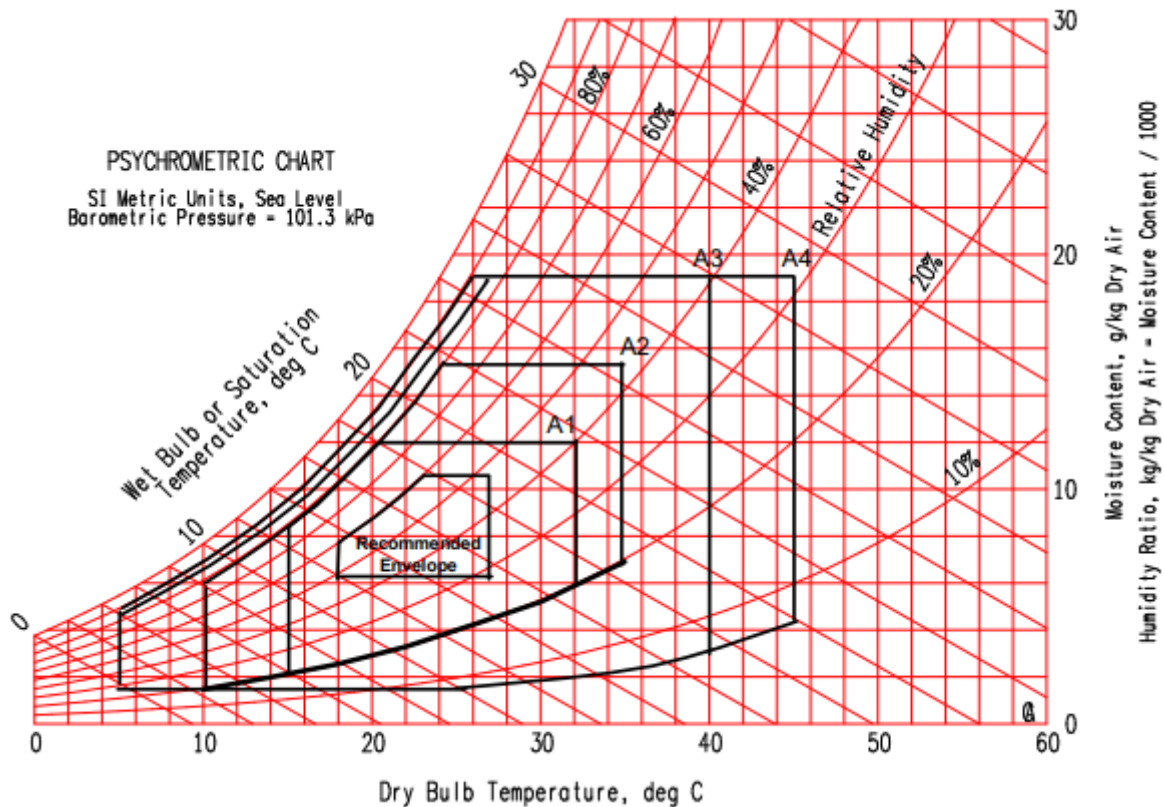

Figure 2.5: ASHRAE temperature ranges for data centers [6].

Oltmanns et al. [2] studied that the high cooling inlet temperatures of up to 60°C for water-cooled data center allow the possibilities for better waste heat utilization.

According to Patel [7] for an efficient air-cooling system, the cold air should be supplied at 25°C and exhaust air should exit the room and come back to CRAC at 40°C.

Ebrahimi et al. [4] suggested that the optimum temperature range to utilize the waste heat in the air-cooled data center at rack exit is 30-40°C while for the chiller water return the suitable temperature range is 16-18°C.

Brunschwiler et al. [8] found that the inlet water temperature can be 60°C to keep the junction temperature under 85°C. For this criterion, the maximum inlet temperature could be as high as 75°C.

Sharma et al. [9] depicted that to recover maximum waste heat the suitable inlet temperature can be in the range 40-40.7°C. They suggested microprocessor junction temperature can be a maximum of 90°C.

3 Process Description

This chapter gives a detailed description of the cooling process implemented in different data centers. As the heat pump is used in the cooling processes, its process description is also detailed in a subchapter.

All the electrical power needed in a data center is transformed into heat, which must be extracted by a suitable cooling system. Based on the design requirements, the proper cooling solution should be configured to achieve high energy efficiency, minimal cost, and reliability. Although most server does not utilize the 100% capacity, the cooling system should be designed to cope up the worst-case scenario. The control and the forecasting of the rise of temperature at the time of a utility power disruption is a vital aspect of the cooling system design. Air-cooled systems are the basis of data center cooling systems that are developing throughout the years to sustain the modernization in the IT equipment. The growing power density demand is pushing the air-cooled system to sectarian cooling units and physical partition of airstream within the data center. Because of this, liquid-cooled systems are becoming appealing and emergent solutions for solving the high-power density requirements of data centers. Nonetheless of the variations among the different cooling systems, some common aspects assure a general description and categorization [10]. The bulk cooling capacity is implemented by the mechanical equipment: such as chilled water systems, direct expansion air-cooled systems, and direct expansion glycol cooled systems. The heat rejection is the end step of the heat removal process where cooling towers and dry coolers are used mostly. The terminal cooling capacity ensures the distribution of the cooling capacity through air or liquid in the air-cooled system and liquid-cooled system, respectively [3].

3.1 Air-cooled systems

The terminal cooling facility should supply air with the appropriate cooling capacity and suitable distribution. As mentioned in [11], certain parameters could impact the cooling efficiency such as ceiling height, where stratification of hot air may take place, raised floor/dropped ceiling height, which is significant for obtaining an accurate air distribution between the IT equipment, and airflow direction in the room. By-pass air and recirculation air are the two vital air distribution problems found in the data center [12]. Re-circulation air appears when airflow to the instrument is not enough and some of the hot air is re-circulated resulting in a significant variation between inlet temperature at the bottom and the top of the rack. A high flow rate or leaks through the cold air path causes by-pass of the cold air. As a result, a portion of the cold air stream omits directly from the cold air supply to the exhaust air despite taking part in the cooling [13]. This poor air management causes a low cooling efficiency and produces a defective cycle of rising local temperatures. The problem is normally avoided by setting the temperature of the cooling system below the IT requirements [14]. The initial step to enhance efficiency is to place effective aisles containment. This is one of the most efficient and less costly strategies to enhance energy efficiency for a data center. The containment enables the physical partition of the air streams, so recirculation or by-pass problem is eliminated. Thus, air at higher temperatures can be provided which results in increased cooling efficiency. To obtain a better airflow distribution, it is also beneficial to localize the terminal cooling equipment nearer to the source. Thus the air-cooled system can

3 Process Description

be classified in room-based cooling, in-row cooling, rack-based cooling [3]. The room row or rack cooling solutions give the same amount of cooling capacity despite being characterized by a different air distribution method. Different cooling efficiency and capital cost the basis of their characterization. It is convenient in in-row cooling and rack-based cooling as they enable shorter airflow path decreasing fan power requirement which eventually increases the efficiency. Besides, they also contribute to the reduction or removal of recirculation phenomena. The different solutions can accommodate different power density. For rack-based cooling systems, the power density is up to 50 kW per rack [15]. On the contrary, rack-based, and in-row cooling requires higher capital costs than the room-based system as they have more cooling units and piping installed [3].

The in-row cooling solution can be attained by putting the terminal cooling equipment between the racks or overhead. The rack-based cooling system may have a closed or open configuration. In the closed design, the servers and terminal cooling equipment are placed within the closed rack enclosure which fully separates the airflow from the rest of the data center [15]. The open design on the other hand, as suggested by Almoli et al. [16] is categorized by a rear door exchanger which assists with a room-based solution in the task of cooling the IT instrument. The rear door can either be active or passive; when dedicated fans regulate the airflow through the back door it is active, and when server fans control the airflow via rear door it is passive. These solutions can be executed in the existing data center with the use of high-density racks, separating them from the room-based cooling system. The in-row cooling system is suggested for the prevailing data center with high-density server racks, from 5kW per rack and above [3].

3.2 Liquid-cooled systems

In the case of high-power density equipment of DCs, air-cooled systems might not be the best choice regarding efficiency and reliability. The liquid-cooled system has high-density power capacity and a broad variety of benefits which makes it able to solve the power requirement. The prime benefit as mentioned in [17] is the higher heat transfer capacity per unit making it able to perform with lower temperature variation between the CPU and the coolant. Furthermore, the system removes two low-efficiency phases of air-cooled systems, heat-sink to air, and air-to-coolant heat transfer. So, a reduction in the system thermal resistance and increment in energy efficiency can be achieved [18]. Higher inlet temperatures can substantially extinguish the requirement of active heat rejection equipment, therefore create the chance of heat reuse [3].

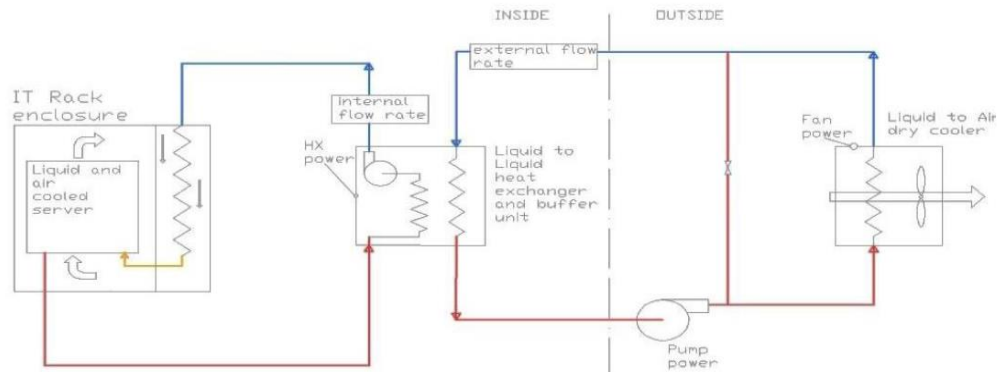

Figure 3.1: Schematic diagram of a liquid-cooled system [3].

A schematic diagram of a typical liquid-cooled system is represented in Figure 3.1. The liquid-cooled system can be built by using micro-channels flow and cold-plate heat exchangers where there will be direct contact with certain parts like CPUs and DIMMs, as described by Zimmermann et al. [19]. In [20, 21] various experimental tests were carried out on the IBM chiller-less data center test facility, with a 15kW fully packed rack, where various-level cooling was obtained via integration of liquid cooling and recirculation air. The cabinet was modeled to accommodate an air-to-liquid heat exchanger to cool the exhaust air from the servers. Flowing through the air-to-liquid heat exchanger the coolant gets in the cabinet and then circulates through the servers finishing the cooling process. The servers were configured to withstand the inflow coolant temperature as high as 45°C. After that, the hot water flows through a liquid-to-liquid heat exchanger extracting the heat to the external loop. The partition between internal and external loop makes it possible to use the water for the internal loop even during the winters season, using a glycol mixture for the external loop. The coolant flows from the heat exchanger to the dry cooler where the heat is rejected. In this setup, differing from the common data center, the cooling system has only three cooling devices comprising of the external dry cooler fans, the external pump, and the internal pump. The test was carried on this facility for 22 hours in a relatively hot summer day.

During the test, the cooling consumption was found only 3.5% [20, 21] of the rack power absorption having an average IT load of 13.16 kW and an average cooling power of 0.442 kW. The average cooling power for a full year could be predicted to be below 3.5% as the test was carried on a hot summer day. The liquid-cooled system is also convenient for significant fan energy saving and a lower noise level. The negative point of the liquid-cooled system is the introduction of liquid within the data center and the possible harm that failure can bring about.

3.3 Description of heat pump process

Heat pump technology gives an effective and long-lasting solution for both heating and cooling applications. A conventional heat pump is a system working on the compression refrigeration cycle powered by either mechanical energy or electricity [22]. In data center cooling for both air-cooled and liquid-cooled process heat pump is an essential part that regulates the cooling

3 Process Description

medium's temperature. Typical refrigerants used in heat pumps are ammonia and chlorinated or fluorinated hydrocarbons [22].

In the refrigeration cycle, the refrigerant circulates due to temperature and pressure difference between the components. The four main components of a refrigeration cycle are the compressor, condenser, expansion valve, and evaporator. Figure 3.2 depicts the mechanical compression refrigeration cycle of a traditional heat pump. The red lines represent high pressure and temperature and the blue line indicates low pressure and temperature of the refrigerant. The cooling effect is produced by the cold liquid refrigerant in the evaporator. A mixture of vapor and liquid phased refrigerant goes into the evaporator where the vaporization of liquid provides the cooling effect before leaving the evaporator. The vapor refrigerant is sucked by the compressor where it gains high pressure and becomes superheated. The output from the compressor then enters the condenser. In the condenser, the vapor refrigerant is cooled and condensed to a saturated liquid. Heat is released from the refrigerant to the ambient. [23, 24]

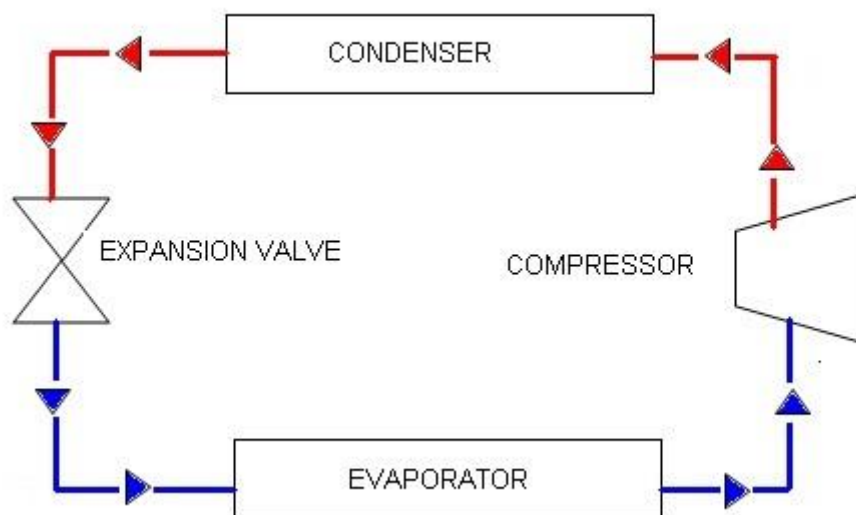

Figure 3.2: Schematic diagram of a heat pump's mechanical compression cycle [23].

The liquid refrigerant then enters the expansion device typically an expansion valve where it is expanded to lower pressure. The liquid refrigerant is partially vaporized due to the expansion process giving a cooling effect in the refrigeration cycle [23, 24]

The efficiency of a heat pump is measured by the coefficient of performance (COP). It is the ratio of the heat delivered or supplied at high temperature to the required power. Equation 3.1 illustrates the COP of the heat pump [22].

3 Process Description

$$COP = \frac{Q_C}{W} \quad (3.1)$$

$$W = Q_C - Q_E \quad (3.2)$$

In Equation 3.2 Q_C is the amount of heat output from the condenser, Q_E is the amount of heat input from the evaporator, and W is the power required in the compressor. When there is no heat loss the work added in the refrigeration cycle is equal to the difference between heat output and heat input [22].

4 Material and energy balance calculation

This chapter gives detail about the relevant material and energy calculation in Aspen HYSYS.

4.1 Simulation setup in Aspen HYSYS.

For calculation and simulation first, the simulation was set up in the Aspen HYSYS. Version 10 of Aspen HYSYS was used for simulation. In the component lists two pure components described. The components are pure water and pure Refrig-22(R-22). R-22 was selected as the refrigerant medium and water which will be supplied for the cooling process in the data center was selected. After that, in the fluid packages, Peng-Robinson (PR) package was selected which is the most common and efficient package for HYSYS simulation. The default parameters for the package was used by Aspen HYSYS. Then the units of the heat pump which are evaporator, condenser, compressor, and expansion valve, were defined for the simulation with relevant streams.

4.2 The energy required calculation from Aspen HYSYS

4.2.1 Total energy requirement calculation

One of the important tasks of the thesis is to perform the calculation in Aspen HYSYS. Two alternatives were selected for the simulation in the Aspen HYSYS. The setup condition for the alternatives is shown in Table 4.1 and Table 4.2.

Table 4.1: Aspen HYSYS input condition for alternative 1

Name	Water 1	Water 6
Temperature (°C)	65	70
Pressure (kPa)	101	101
Fluid package	Peng-Robinson	

Table 4.2: Aspen HYSYS input condition for alternative 2

Name	Water 1	Water 6
Temperature (°C)	65	80
Pressure (kPa)	101	101
Fluid package	Peng-Robinson	

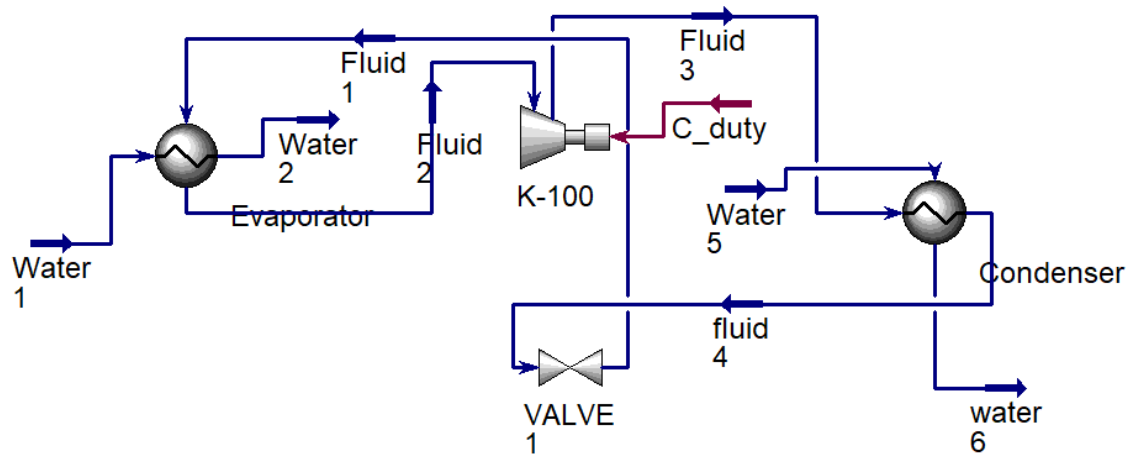

Figure 4.1: Model representation of the DC heat recovery process via heat pump in Aspen HYSYS

Figure 4.1 represents the model of the DC heat recovery process with the help of a heat pump in Aspen HYSYS. Water 1 is the cooling water from the data center and water 6 is water supplied to the district heating network. The result of the simulation was obtained in a very short time as the simulation in Aspen HYSYS is very quick and efficient. The simulation results for the two alternatives are presented in Table 4.3 and Table 4.4.

Table 4.3: Results of material and energy balance achieved from Aspen HYSYS for alternative 1

Name	Water 1	Fluid 1	Water 2	Fluid 2	Fluid 3	Water 5	Water 6	Fluid 4
Vapour Fraction	0	0.2564	0	1	1	0	0	0
Temperature (°C)	65	51.24	55	51.24	88.84	40	70	74.25
Pressure (kPa)	101	2000	101	2000	3280	101	101	3280
Molar flow (kgmole/h)	55.51	4.369	55.51	4.369	4.369	20.94	20.94	4.369
Mass flow (kg/h)	1000	377.8	1000	377.8	377.8	377.1	377.1	377.8

4 Material and energy balance calculation

Liquid volume flow (m³/h)	1.002	0.308	1.002	0.308	0.308	0.3779	0.3779	0.308
Heat flow (kJ/h)	- 1.572e +07	- 2.131e +06	- 1.576e +07	- 2.088e +06	- 2.082e +06	- 5.968e +06	- 5.919e +06	- 2.131e +06

Table 4.4: Results of material and energy balance achieved from Aspen HYSYS for alternative 2

Name	Water 1	Fluid 1	Water 2	Fluid 2	Fluid 3	Water 5	Water 6	Fluid 4
Vapour Fraction	0	0.406	0	1	1	0	0	0
Temperature (°C)	65	51.24	55	51.24	104.7	40	80	84.33
Pressure (kPa)	101	2000	101	2000	4000	101	101	4000
Molar flow (kgmole/h)	55.51	5.419	55.51	5.419	5.419	17.02	17.02	5.419
Mass flow (kg/h)	1000	468.6	1000	468.6	468.6	306.6	306.6	468.6
Liquid volume flow (m³/h)	1.002	0.3820	1.002	0.3820	0.3820	0.3072	0.3072	0.3820
Heat flow (kJ/h)	- 1.572e +07	- 2.633e +06	- 1.576e +07	- 2.590e +06	- 2.580e +06	- 4.851e +06	- 4.798e +06	- 2.633e +06

4.2.2 Calculation of COP for heat pump

For alternative 1

Evaporation temperature from the simulation is found 51.24°C

Condensation temperature from the simulation is found 74.25°C

From the simulation the amount of heat output from the condenser, $Q_C = 48950$ kJ/h

From the simulation power required in the compressor, $W = 5651$ kJ/h

$$COP = \frac{Q_C}{W} = \frac{48950}{5651} = 8.66$$

For alternative 2

Evaporation temperature from the simulation is found 51.24°C

Condensation temperature from the simulation is found 84.33°C

From the simulation the amount of heat output from the condenser, $Q_C = 53130$ kJ/h

From the simulation power required in the compressor, $W = 9829$ kJ/h

$$COP = \frac{Q_C}{W} = \frac{53130}{9829} = 5.4$$

So, when the cooling water from the data center is 65°C and the supply water to district heating is 70°C the COP is found 8.66. On the other hand, when the cooling water from the data center is 65°C and the supply water to district heating is 80°C the COP is found 5.4

5 Cost calculation

This chapter represents the cost calculation related to the heat recovery process.

5.1 Energy cost calculation

For the energy cost calculation, simple assumptions are made. The price of electricity is estimated to be 0.1 EUR/kWh, and the district heat price was specified to 0.05 EUR/kWh.

So, the formula for the estimated economic potential is presented in equation 5.1.

$$\begin{aligned} & \text{Economic potential} \\ &= \frac{0.05 \frac{\text{EUR}}{\text{kWh}} \cdot \text{Recovered energy} - 0.1 \frac{\text{EUR}}{\text{kWh}} \cdot \text{Electricity consumption}}{\text{COP}} \quad (5.1) \end{aligned}$$

Oltmanns et al. [2] have found that in 2018 the Telia data center in Helsinki, Finland supplied 200GWh/a in the nearby city of Espoo. So, taking this recovered heat value as a reference to the economy for a large data center facility can be calculated.

$$\text{Economic potential for Data Center} = \frac{0.05 \frac{\text{EUR}}{\text{kWh}} \cdot 200\text{GWh} - (0.1 \frac{\text{EUR}}{\text{kWh}} \cdot \frac{200\text{GWh}}{\text{COP}})}{\text{COP}}$$

$$\text{For alternative 1, economic potential} = \frac{0.05 \frac{\text{EUR}}{\text{kWh}} \cdot 200\text{GWh} - (0.1 \frac{\text{EUR}}{\text{kWh}} \cdot \frac{200\text{GWh}}{8.66})}{8.66} = 0.89 \text{ MEUR}$$

$$\text{For alternative 2, economic potential} = \frac{0.05 \frac{\text{EUR}}{\text{kWh}} \cdot 200\text{GWh} - (0.1 \frac{\text{EUR}}{\text{kWh}} \cdot \frac{200\text{GWh}}{5.4})}{5.4} = 1.17 \text{ MEUR}$$

For the case of omitting heat pump, all the 200GW energy can be utilized to district heating network, which is worth of value 10 MEUR, as per kW district heat price is 0.05 EUR.

5.2 Investment cost calculation

The investment cost is mostly dependent on the installation cost of the heat pump facility. Other costs can be negligible for the heat recovery solution. The heat pump cost is very critical to determine. According to [25] the installed cost for a 2 kW pump is 552.4 EUR. Thus, for a 24 MW capacity data center, the cost of the heat pump will be equal to 6.6 MEUR. Hence for a large amount of heat recovery from DC, it can be estimated that investment of heat pump cost is high enough.

5.3 Evaluation of pipeline cost

Pipeline cost is very much dependent on the distance between the data center heat recovery facility to the district heating network. Furthermore, the environment and climate will play a vital role in determining the materials of the pipeline. So, the cost of the pipeline is variable depending on the condition. However, it can be optimized that the heat pump cost will be relatively larger than the pipeline cost.

6 Discussion

6.1 Based on Aspen HYSYS calculation

The waste heat recovered from data centers needs to be connected to the district heating network. As the quality of the heat is low, a heat pump can be very useful in the situation. The heat pump will increase the temperature of the heat by the refrigeration process. The cooling effect of refrigerant will increase temperature. For the two alternatives evaporation temperature is the same 51.24°C. However, condensation temperature is varied in two cases. For one alternative it is 74.25°C giving a COP value of the heat pump 8.66 while the other alternative produces the COP value of 5.4 with a condensation temperature of 84.33°C. This shows that when the heat pump will supply high-temperature water to the district heating network it will generate a low COP and vice versa.

6.2 Economic potential analysis

In the case of economic optimization, three alternatives were evaluated. The first one is without a heat pump all the recovered 200 GW can be utilized which will be worth 10 MEUR. The alternative with relatively low COP will produce a higher economic potential of 1.17 MEUR and higher COP will give a lower economic value of worth 0.89 MEUR. The comparison of the economic potential for different heat recovery scenarios is represented in Figure 6.1.

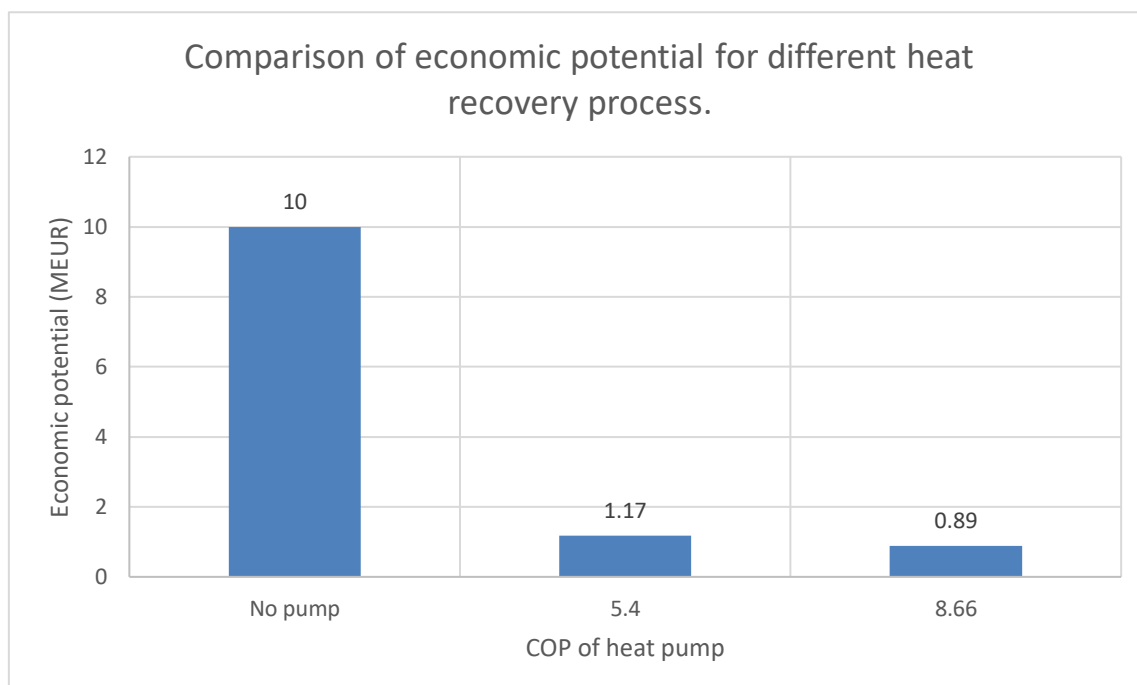

Figure 6.1: COP of pump versus economic potential value

6 Discussion

Finally, if the heat recovery process can be run from waste heat of the data center for 10 years, all the three alternatives will be economical. The heat pump installation cost estimated to be 6.6 MEUR. Hence, the 10 year-long run heat recovery project will give a positive net present value. The value will be for no heat pump, heat pump of COP 5.4, and heat pump of COP 8.66 respectively 93.4 MEUR, 5.1 MEUR, and 2.3 MEUR. For all the cases other costs like pipeline invest and operational cost are not considered, as the reasonable estimation is not possible of some uncertainties.

7 Recommendation for future work

The thesis work was carried on based on the literature study and theoretical work. For the exact analysis, there need some accurate temperature specifications which should be given by the data center and heat recovery unit or companies. For instance, the cooling temperature required for a typical data center should be specified. Again, the recovered heat which will be supplied to a present district heating network or heat supply company the temperature requirement is also precise. For the success of the thesis or project in the future, these numbers should be collected. Because of the pandemic situation going on around the world, despite trying to connect with two data centers the work could not be finished. But The work will give a significant resource for future work. Moreover, some other commercial simulation tools like Provision, ProMax, or Aspen Plus can be used to simulate the process similarly. The variation in different simulation can also be analyzed as a part of future work.

8 Conclusion

The depletion of fossil fuel energy resources and demanding energy consumption of the world has pushed scientists and researchers to expand renewable energy resources. Data centers play a vital role in producing excess or unutilized heat, which is a momentous and significant source of renewable energy. Moreover, the effect of global warming is also needed to be reduced. So, to make the data center more energy efficient waste heat recovery technology is emerging worldwide. The thesis deals with the heat recovery technology study. The thesis started with the literature study of different heat recovery technology. Cooling principle of different data centers typically air-cooled and water-cooled systems are also studied to find the typical cooling temperature.

The recovered heat from a data center is needed to be connected to a district heating network for the proper utilization. However, the heat from the data center is of low quality should be improved. A heat pump can serve the purpose of improving heat quality. Simulation and economical optimization at different conditions in Aspen HYSYS were carried out. Three cases were evaluated to utilize the waste heat. One case was without a heat pump in which water will leave the DC at 65°C and enter the district heating network at 70°C. The second alternative is a little increase in the temperature in the heat pump. The cooling water temperature from the DC is 65°C and the DH supply temperature is 80°C. In the third scenario, the cooling water temperature is 65°C and the DH supply temperature is 80°C. R-22 refrigerant was used in the simulation tool Aspen HYSYS with Peng-Robinson fluid package. The COP for the two heat pump alternatives was calculated 8.66 and 5.4. For the economic potential calculation of a 200GWh/a recovered heat data center, the value for the first alternative without heat pump is worth 10 MEUR, for the second alternative it is 0.89 MEUR and for the third case, it is 1.17 MEUR. The most economical alternative was without heat pump and the heat pump with the lowest COP gives second economic value. The sensitivity calculations were performed as the analysis is dependent on the temperature specifications. Precise temperature requirements from the DC and DH company are required to find the exact economic potential. Furthermore, district heating prices, electricity costs, heat pump costs, etc. are estimated to find the economic value for the case. Pipeline cost depends on the climate, length of the connection, and environmental condition which makes it difficult to make a suitable estimation. All the scenarios found to be economically beneficial. So it can be concluded that the waste heat recovery from a data center in utilizing the district heating facility will produce a significant economical profit. Utilizing the waste heat from data centers, will create a positive impact on the global warming situation and also serve the purpose of expanding the renewable energy source.

References

- [1] H. Geng, *Data center handbook*. John Wiley & Sons, 2014.
- [2] J. Oltmanns, D. Sauerwein, F. Dammal, P. Stephan, and C. Kuhn, "Potential for waste heat utilization of hot-water-cooled data centers: A case study," *Energy Science & Engineering*, 2020.
- [3] A. Capozzoli and G. Primiceri, "Cooling systems in data centers: state of art and emerging technologies," *Energy Procedia*, vol. 83, pp. 484-493, 2015.
- [4] K. Ebrahimi, G. F. Jones, and A. S. Fleischer, "A review of data center cooling technology, operating conditions and the corresponding low-grade waste heat recovery opportunities," *Renewable and Sustainable Energy Reviews*, vol. 31, pp. 622-638, 2014.
- [5] E. Oró, R. Allepuz, I. Martorell, and J. Salom, "Design and economic analysis of liquid cooled data centres for waste heat recovery: A case study for an indoor swimming pool," *Sustainable cities and society*, vol. 36, pp. 185-203, 2018.
- [6] ASHRAE, "Thermal guidelines for data processing environments—expanded data center classes and usage guidance," *Whitepaper prepared by ASHRAE technical committee (TC)*, vol. 9, 2011.
- [7] C. D. Patel, "A vision of energy aware computing from chips to data centers," in *The international symposium on micro-mechanical engineering*, 2003.
- [8] T. Brunschwiler, B. Smith, E. Ruetsche, and B. Michel, "Toward zero-emission data centers through direct reuse of thermal energy," *IBM Journal of Research and Development*, vol. 53, no. 3, pp. 11: 1-11: 13, 2009.
- [9] C. S. Sharma, S. Zimmermann, M. K. Tiwari, B. Michel, and D. Poulikakos, "Optimal thermal operation of liquid-cooled electronic chips," *International journal of heat and mass transfer*, vol. 55, no. 7-8, pp. 1957-1969, 2012.
- [10] L. Bellia, A. Capozzoli, P. Mazzei, and F. Minichiello, "A comparison of HVAC systems for artwork conservation," *International Journal of Refrigeration*, vol. 30, no. 8, pp. 1439-1451, 2007.
- [11] R. R. Schmidt, E. E. Cruz, and M. Iyengar, "Challenges of data center thermal management," *IBM Journal of Research and Development*, vol. 49, no. 4.5, pp. 709-723, 2005.
- [12] A. Capozzoli, M. Chinnici, M. Perino, and G. Serale, "Review on performance metrics for energy efficiency in data center: The role of thermal management," in *International Workshop on Energy Efficient Data Centers*, 2014: Springer, pp. 135-151.
- [13] A. Capozzoli, G. Serale, L. Liuzzo, and M. Chinnici, "Thermal metrics for data centers: A critical review," *Energy Procedia*, vol. 62, pp. 391-400, 2014.
- [14] J. Niemann, K. Brown, and V. Avelar, "Impact of hot and cold aisle containment on data center temperature and efficiency," *Schneider Electric Data Center Science Center, White Paper*, vol. 135, pp. 1-14, 2011.
- [15] K. Dunlap and N. Rasmussen, "Choosing between room, row, and rack-based cooling for data centers," *APC White Paper*, vol. 130, 2012.
- [16] A. Almoli, A. Thompson, N. Kapur, J. Summers, H. Thompson, and G. Hannah, "Computational fluid dynamic investigation of liquid rack cooling in data centres," *Applied energy*, vol. 89, no. 1, pp. 150-155, 2012.
- [17] Y. Q. Chi *et al.*, "Case study of a data centre using enclosed, immersed, direct liquid-cooled servers," in *2014 Semiconductor Thermal Measurement and Management Symposium (SEMI-THERM)*, 2014: IEEE, pp. 164-173.

References

- [18] M. Ohadi, S. Dessiatoun, K. Choo, M. Pecht, and J. V. Lawler, "A comparison analysis of air, liquid, and two-phase cooling of data centers," in *2012 28th Annual IEEE Semiconductor Thermal Measurement and Management Symposium (SEMI-THERM)*, 2012: IEEE, pp. 58-63.
- [19] S. Zimmermann, I. Meijer, M. K. Tiwari, S. Paredes, B. Michel, and D. Poulikakos, "Aquasar: A hot water cooled data center with direct energy reuse," *Energy*, vol. 43, no. 1, pp. 237-245, 2012.
- [20] M. Iyengar *et al.*, "Server liquid cooling with chiller-less data center design to enable significant energy savings," in *2012 28th annual IEEE semiconductor thermal measurement and management symposium (SEMI-THERM)*, 2012: IEEE, pp. 212-223.
- [21] M. Iyengar *et al.*, "Extreme energy efficiency using water cooled servers inside a chiller-less data center," in *13th InterSociety Conference on Thermal and Thermomechanical Phenomena in Electronic Systems*, 2012: IEEE, pp. 137-149.
- [22] L. E. Øi and I. Y. Tirados, "Heat Pump Efficiencies simulated in Aspen HYSYS and Aspen Plus," 2015.
- [23] Simple, Science, and Technology. (2011, 15.05.2020). *Refrigeration Cycle* [Online]. Available: <http://simple-engineering.blogspot.com/2011/01/refriger%20nvbfc%20dxz%C3%A5ation-cycle.html>.
- [24] R. Smith, *Chemical process: design and integration*. John Wiley & Sons, 2005.
- [25] H. Nishihata, R. Kempener, G. Simbolotti, and G. Tosato, "Heat Pumps—Technology Brief," *International Energy Agency (IEA)—Energy Technology Systems Analysis Programme (ETSAP)/International Renewable Energy Agency (IRENA): Paris, France*, p. 24, 2013.

Appendices

Appendix A Master thesis task description

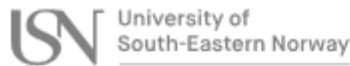

Faculty of Technology, Natural Sciences and Maritime Sciences, Campus Porsgrunn

FMH606 Master's Thesis

Title: Utilization of excess heat from data centers

USN supervisor: Lars Erik Øi

External partner: Green Mountain or Skien Datasenter Utvikling

Task background:

Data centers are delivering facilities to locate large computers for storing data including data access. The large computers are cooled by air (or possibly cooling water). The excess heat is normally regarded as lost energy. In principle, the excess heat can be utilized. One way to increase the potential for utilization is to increase the temperature on the cooling air or cooling water outlet. One possibility for utilization is district heating.

Task description:

1. Literature search on cooling principles in computers. Of special interest is to find maximum or optimum temperature on cooling air or cooling water.
2. Process description of cooling processes for a large data center. One case should be for traditional cooling technology, and another should be a case with a high outlet temperature.
3. Calculation of a material and energy balance of the cooling process for at least one large data center. Also calculation of the economic potential for specific energy recovery solutions.
4. Evaluations of possible ways to utilize waste heat from a data center. The possibility of district heating should be evaluated. Possibilities including heat pumps and power production should also be evaluated.
5. Simulations and economical optimization at different conditions in ASPEN HYSYS.

Student category: PT or EET students

Practical arrangements:

The work will be carried out mainly at the University of South-eastern Norway.

Supervision:

As a general rule, the student is entitled to 15-20 hours of supervision. This includes the necessary time for the supervisor to prepare for supervision meetings (reading material to be discussed, etc).

Address: Kjølnes ring 56, NO-3918 Porsgrunn, Norway. Phone: 35 57 50 00. Fax: 35 55 75 47.

Signatures:

Supervisor (date and signature): 28/1-20 

Student (write clearly in all capitalized letters): MOHAMMAD SHARFUDDIN

Student (date and signature): 28/1-2020 

Simulation of heat recovery from data centers using heat pumps

Mohammad Sharfuddin¹ Lars Erik Øi^{*1}

¹University of South-Eastern Norway, N-3901 Porsgrunn, Norway

Keywords: data center, district heating, heat recovery, heat pump, Aspen HYSYS

Abstract

Large amounts of digital data requires to be stored and for that data centers are built around the globe. Electric power is the main energy input and heat is the main energy output from these data centers. This work is about the utilization of the excess heat which is the by-product of data center operation. To connect the heat from data centers to a district heating network, a heat pump might be necessary to increase the temperature of the heat. The economic potential for different conditions and different heat recovery solutions are evaluated. In Table 1 a suggested heat chain from a data center to a district heat system is indicated with traditional and optimistic temperatures.

Simulations and economical optimization at different conditions in Aspen HYSYS were carried out. Especially three alternatives were evaluated. The first is an alternative without a heat pump in which the cooling water leaves the data center at 80 °C and enters the district heat network at 70 °C. The second is an alternative with a slight temperature increase in the heat pump. The cooling water temperature from the data center is 65 °C and the temperature to the district heat system is 70 °C. The third is an alternative with a higher temperature increase in the heat pump. The cooling water temperature from the data center is 65 °C and the temperature to the district heat system is 80 °C. The COP (Coefficient of Performance) in a heat pump for these alternatives were calculated using the refrigerant R-22 in the simulation program Aspen HYSYS. The estimated economic potential for each alternative was calculated by estimated values on electricity cost and district heat price. In one alternative, the electricity cost was specified to 0.1 EUR/kWh, and the district heat price was specified to 0.05 EUR/kWh. For the alternatives using heat pumps, the capital cost was estimated assuming that the heat pump investment was dominating [1, 2].

Table 1: Heat chain from computer cooling to water-based heating system

Heat delivery system	Traditional Temperature	Optimistic Temperature	Specification Temperature
Computer	60	90	-
Air cooling	40	80	-
Water secondary cooling loop	30	70	70
Heat pump (Evaporation & condensation)	20-80	Skip	51-74 & 84-74
Transport pipe	70	50	50
Water based heat delivery/return	60-50	40-30	40-30

The evaluation of traditional, optimistic and specification temperature for computer cooling to water-based heating system is represented in Table 1. The table portrays the three system with numbers. In a sense, it is the comparison as well as the summary of the three different type of water-based heating system.

The COP for the two heat pump alternatives were calculated to be 8.7 and 5.4, respectively. The economy for a large data center facility with recovered waste heat of 200 GWh/year was calculated over a period of 10 years. For the specified conditions, the net present value was calculated to be large and positive for all the alternatives. As expected, the most economical alternative was without a heat pump, and the most economical heat pump was the one with the lowest COP. Sensitivity calculations were performed to show dependencies of temperatures, district heating price, electricity cost, heat pump cost, COP and pipeline cost. Pipeline cost is very much dependent on the length and the local conditions for which it was not possible to make a reasonable estimation.

The calculations show that there is a large potential in using waste heat from data centers for district heating.

References:

- [1] J. Oltmanns, D. Sauerwein, F. Dammel, P. Stephan, and C. Kuhn, "Potential for waste heat utilization of hot-water-cooled data centers: A case study," *Energy Science & Engineering*, 2020.
- [2] ASHRAE, "Water-cooled servers, Common Designs, Components and Processes" ASHRAE Technical Committee 9.9, Atlanta, 2019.

{ ADDIN }