

"This is the peer reviewed version of the following article:

Sandberg, M. , Kokkula, S. and Muller, G. (2019), Transitioning from technical 2D drawings to 3D models: a case study at defense systems. *INCOSE International Symposium*, 29: 879-894.

which has been published in final form doi:[10.1002/j.2334-5837.2019.00641.x](https://doi.org/10.1002/j.2334-5837.2019.00641.x)***This article may be used for non-commercial purposes in accordance with Wiley Terms and Conditions for Use of Self-Archived Versions."***



Transitioning from technical 2D drawings to 3D models: a case study at defense systems

Martin Sandberg
Kongsberg Defence & Aerospace
martysand91@gmail.com

Satyanarayana Kokkula
University of South-Eastern Norway
Satyanarayana.Kokkula@usn.no

Gerrit Muller
University of South-Eastern Norway
gerrit.muller@gmail.com

Copyright © 2019 by Martin Sandberg. Permission granted to INCOSE to publish and use.

Abstract. Companies in the defense and aerospace industry are experiencing long time-to-market and high costs related to the development of new systems. Companies use traditional design elements such as technical 2D drawings and manual work along the development chain. Owing to today's software capabilities, a change to more automated processes is possible, where the use of 3D models as governing documents through the entire development process holds a natural part.

This paper studies a 3D model-based definition (MBD) approach to the design development work at Kongsberg Defence & Aerospace. Using a pilot project, we researched the current design processes and the effect an MBD approach would have. We found that an MBD approach would reduce the time-to-market and cost, since it eliminates the need for a technical 2D drawing and streamlines the development work. In addition, it reduces project risk by enabling early validation of the design.

Introduction

Domain. This paper focuses on the defense and aerospace industry. Several system classes exist within this industry, ranging from small volume and costly systems such as submarines and fighter jets that require multiple years of development and manufacturing, to the comparatively less complex, cheaper, and larger volume systems such as remote weapon stations (RWS). This study will focus on the design development processes related to RWS systems. An RWS is a platform-mounted system that can be installed on vehicles, ships, and man-portable stand-alone towers, see Figure 1. It allows the operator to use and control the weapon from a safe environment. The system can operate light, medium, and heavy machine guns. Customers ordering RWS systems use a variety of vehicles and weapons, which requires flexibility in the design. The industry seeks design processes that reduce time-to-market and cost, and to be more agile and effective. The industry sees automated design and manufacturing as a necessary future direction to achieve this.

Company. Kongsberg Defence & Aerospace (KDA) is a subdivision of the technology group KONGSBERG. KDA is a well-known supplier within the defense domain. KDA develops systems for command and control, surveillance, communication, remote weapon stations, missiles, and composite structures. The product portfolio is comprehensive, where the area of use ranges from underwater to surface, land, and air to space. The division that is involved with remote weapon stations is the focus of this study. KDA has delivered more than 18,000 RWS systems to 18 different nations and is a world-leading supplier of such systems. At the end of 2017, KDA had 2421 employees and the annual revenue was MNOK 6333 (KONGSBERG, 2017).



Figure 1. A remote weapon station alone (I) and mounted on top of a vehicle (II).

Problem. The competition to win contracts within the defense industry is fierce. Several companies compete in the same domain, and the decisive factors are often time-to-market and price. As of today, KDA is designing RWSs using SolidWorks 3D modelling software. Engineers perform the design process in two steps. They first create a 3D model. Then they translate the 3D model into technical 2D drawings. The process of handing over the technical 2D drawings is ineffective in terms of both time-to-market and cost, according to the management and engineers at KDA. The time to produce and approve technical 2D drawings can range from one day to one week, depending on the complexity of the part. The 2D drawings must completely represent the 3D physical model in order to provide the manufacturer complete information on the component. Overall, this requires multiple views, sections, and details.

This translation from 3D to 2D becomes even more costly as concurrent or subsequent changes to the 3D model require manual updates to the 2D drawings as well. If one should use a fully digital design tool, where the 3D model is the governing element, this extra manual step does not exist. The focus would be solely on the 3D model. This should also eliminate the errors that occur when the 3D and 2D models are not properly synchronized.

The existing unified CAD format, standard for exchange of product model data (STEP), is too simple and cannot transfer design properties that are essential for the manufacturing process from the original 3D model. These properties are required in the workflow and a richer format of the 3D model is therefore necessary.

Goal. KDA wants to be more competitive by reducing the time and cost of developing new systems. This study aims to formulate an MBD methodology. An effective agile design development process would reduce the time-to-market and cost of their systems, hence improving their overall competitiveness. To realize this, we propose a system that will streamline the overall design process, eliminate manual duplication of work, and enable automated design validation.

Solution. The proposed solution uses an MBD approach as its foundation, where the technical documentation handover resides in the 3D model. This is sensible since the 3D model is the artifact that the engineers produce first. We study the current situation and examine what material the mechanical engineers should include in the handover.

Research questions. In this study, we ask the following questions:

- What competences and tools do KDA and its mechanical manufacturing suppliers need to use the MBD technique?
- What investments does KDA need to make for the transition to an MBD approach?
- What cost and time benefits may KDA expect from an MBD approach?

We address the stated questions by researching the current design processes and developing a new outline of the design process in accordance with MBD. We interview internal and external stakeholders to analyze their design-process needs. We study drawbacks with the current processes and identify time and cost drivers. By using system modelling and user interviews, we evaluate the new proposed process.

Case. The RWS sub-assembly that we use for this study is the azimuth manual release (Figure 2). Its function is to enable the operator to manually rotate the RWS along the azimuth axis when the servo system is disabled.



Figure 2. The sub-assembly related to the case.

Research method

Systems engineering domain. We used the methodologies of systems thinking to analyze the implementation process. Systems thinking is a preferable method to use when performing deep analysis and focuses on several aspects of the system; the big picture view, dynamics, soft factors, patterns, and life-cycle (Walden et al., 2015). We included several stakeholders in the study to analyze the majority of the value chain. This helped us to keep the big picture view and to have several aspects and scenarios in focus during the project.

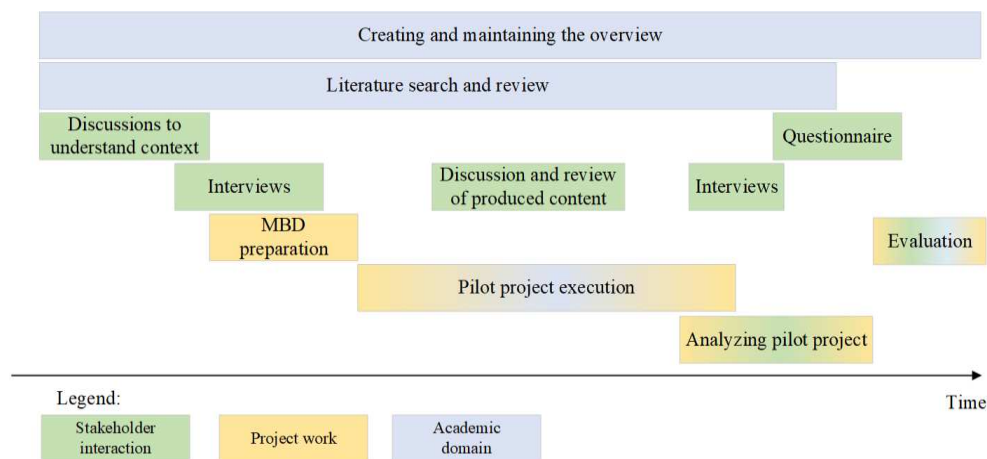

Figure 3. The research method of the project.

Initial discussions. We held baseline conversations to understand the context and to present our approach to the employees at KDA. The conversation was of a door-to-door nature and considered as informal.

Interviews. We performed interviews and presentations with both internal and external stakeholders to understand the problem, current processes, and needs. This included field visits to mechanical manufacturers and RWS assembly facilities. We conducted interviews during the entire time span of

the project to target specific elements and to obtain information when the engineers were both new to and accustomed to the MBD approach.

Discussions and reviews. We included process reviews with the employees to enable feedback on the conducted work. The process reviews functioned as a means of evaluation and validation of the theoretical processes we formulated.

MBD preparation. We organized an MBD preparation phase to ensure that all necessary software programs and licenses were present. The preparation made the execution phase effective and enabled us to focus solely on the pilot project.

Pilot project. To narrow the scope and to be able to fully understand and analyze the MBD approach, we selected, together with KDA, a sub-assembly of an RWS to function as a pilot project. The mechanical design process is the same for all components and assemblies, so our findings should be relevant for designing a full RWS system.

Analysis. We analyzed the pilot project progress and result. We based the analysis of the project work on feedback from stakeholders.

Questionnaire. The engineers contributed feedback by answering a questionnaire. The respondents attended a presentation dealing with the result of the pilot project before answering the questionnaire. The presentation highlighted the new process with fully defined 3D models using the MBD approach. The questionnaire included 10 questions, with both multiple-choice answers (using the Likert scale) and open questions. The Likert scale is an ordinal level of measurement where the response types have a ranking order. It is not suitable to analyze in terms of mean and standard deviation (Jamieson, 2004). This is because we cannot consider the intervals between the response type groups as equal. Therefore, we use net promoter score (NPS) and overall impression when analyzing the result. NPS is a strict yet effective way to measure loyalty, future actions, and behavior of a group (Reichheld, 2003). An $NPS > 0$ is per definition good. An $NPS \leq 0$ indicates that the overall satisfaction level is low. In these cases, the System Engineer should dig deeper to understand the underlying factors. The calculation includes subtraction of the neutral and disagreeing responses (detractors) from the positive, strongly agreeing responses (promoters).

The distribution between multiple choice and open questions allows for a broader collection of data, ranging from an informal, free format to a formal, standardized format (Muller, 2013).

Evaluation. We used interviews and questionnaires as a mean to evaluate the project. The evaluation incorporates all parts of the project including the project work, academia and research related theories, and the stakeholders' impressions. We did this to obtain a bird's eye perspective to cover as much as possible and to be able to pinpoint specific critical elements.

State-of-the-art

The digital era and automation. Industry 4.0 is a German initiative aimed at implementing automation and data transfer to the manufacturing industry; to create smart factories. The term Industry 4.0 is a hot topic nowadays, and a framework that deals with the shift that the industry must make to be able to meet future demands (Lasi et al., 2014). The framework involves increasing flexibility, reducing the time spent on development stages (time-to-market), and including the ecological and environmental aspects of the processes (not solely focusing on economics).

Why is the design model important? The first aspect to consider is cost. The new generation of design models allows full automation, and one can assume that this shift implies large investment costs. The implementation process does indeed cost money, but the management and decision makers in several companies that have performed it witness that it is money well spent (Widman et al., 2016). This is because digitization enables strategic change. A digital model gives users the possibility of en-

gaging in projects and competing for orders that previously were out of bounds. New business opportunities can arise following such an implementation because the company becomes more flexible and dynamic.

Lundqvist et al. (2016) states that digital tools can reduce time to market significantly since they could incorporate the validation and review process as an integrated step linked to the concept modelling process. All employees would have access to the updated models and all related information at any given time. In addition, the simulations and calculations could take place at an early phase since realistic and fully defined 3D models are present early in the process. There is also room for extra simulation iterations, ensuring quality and performance. Digital design processes enable quick and easy sharing of information and technology platforms between different departments within companies. Marion et al. (2015) claims that this would, in theory, reduce both cost and time spent; a statement indicating that there is much to gain if one can achieve interfaces between the design tools and the IT system.

Value of systems engineering. The development of systems has become far more complicated than it previously was. Increasing changes and complexity that today hold a natural presence in system development, demand structured work and a holistic mindset from the systems engineer. Systems engineering helps to reduce risk related to the development of new complex systems. This is important since risk is often associated with cost. Walden et al. (2015) claims that there is a big difference between life cycle cost and committed costs (Figure 4). The figure illustrates that when the engineers have completed the design phase, which averages 15% of the total life cycle costs, 85% of the costs are already committed. This highlights the importance of a robust and comprehensive approach when developing new systems. Figure 4 also highlights that early verification and validation of designs are key success factors when it comes to managing cost. To detect and adjust errors early in the design process is crucial since the cost to extract defects later in the process increases significantly.

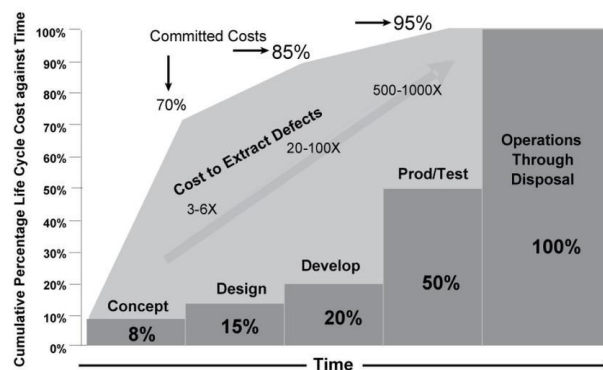

Figure 4. Committed life cycle cost against time (Walden et al., 2015).

Implementation of design tools. To increase performance related to product quality, reduced cost, and shorter time-to-market, research suggests that companies should focus on and improve the design-related processes positioned early in the development process (Lehto et al., 2011). In general, there is a need for a full implementation of a design tool if it shall contribute in a positive manner (Booker, 2012). However, partial and small-scale implementation provides insight of the concept, and whether one should continue with a big-scale implementation process or not. This induces the urgency of a comprehensive analysis and preparation for the implementation to receive a positive result.

To enable automated processing, steps such as feeding data to machining and measurement machines using the technology and standards available today, the format must be rich. In these cases, the existing standard format, STEP files, would not be enough. To utilize the power of automation, these applications are dependent on the active use of fully defined 3D models in the receiver domain.

System context: current state in the company

Stakeholders. As a first effort to understand the system of interest and its current processes, we formulated a stakeholder diagram (Figure 5). The stakeholder diagram contains both internal and external stakeholders and a rationale of how they are affected and/or how they affect the system. The focus of our study was on the mechanical engineering processes, but to reach the top objective of our research, improving KDAs competitive ability, it was necessary to include key actors and their needs. The MBD approach is a comprehensive method and requires all involved departments to work together to be effective.

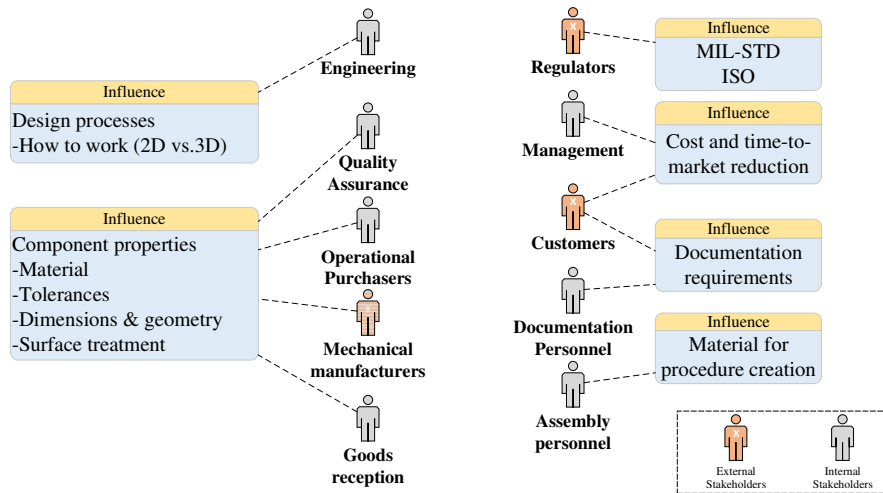

Figure 5. Stakeholders of the design and development process and their influence with the system.

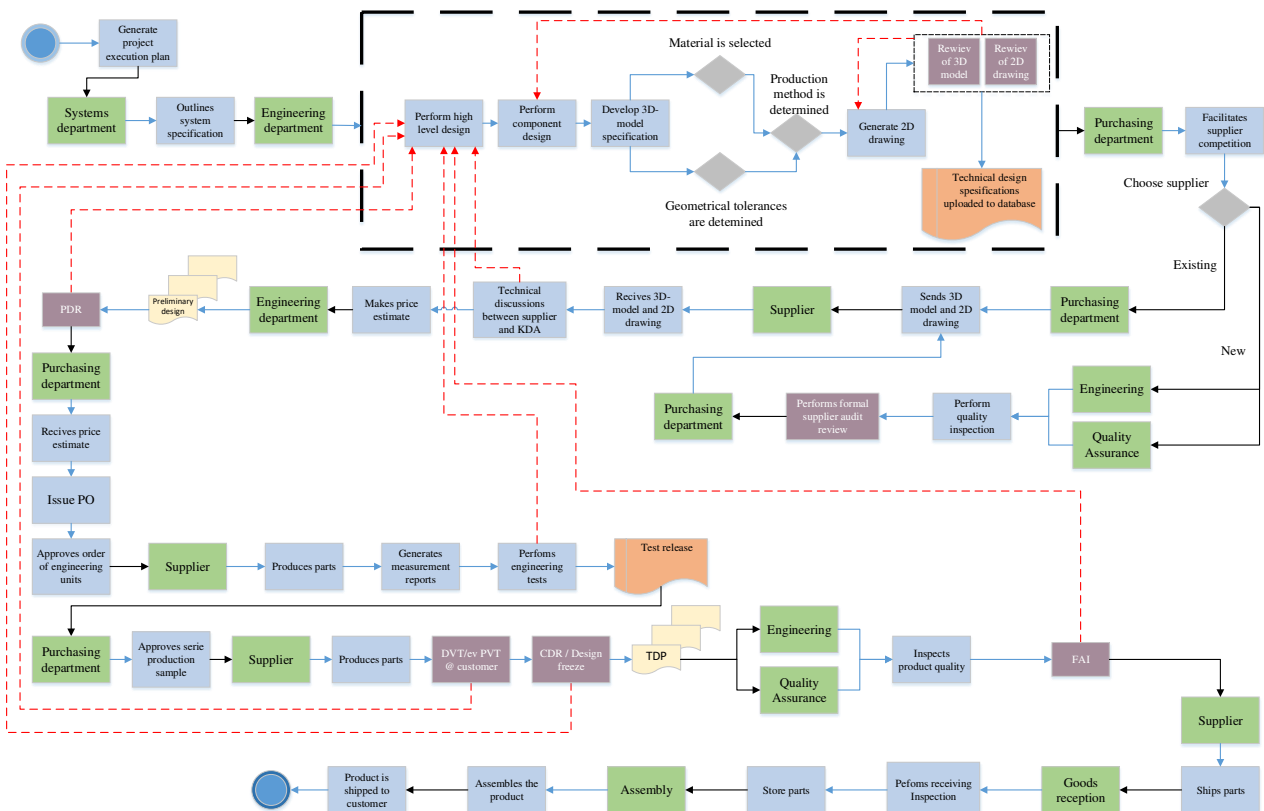

Figure 6. Process flow diagram describing the design and development for mechanical components.

Process flow. We mapped the current design and development of mechanical components processes at KDA (Figure 6). This increased our understanding of the routing and what steps are dependent upon each other as it stands today. As seen in the figure, the design process from order to delivery is

comprehensive and includes several actors and elements. The process flow diagram was an iterative and living model, and we performed regular reviews of it together with employees at KDA. For the purpose of this study, our focus was on the actions taking place inside the dotted rectangle on the top of the figure.

Technical information flow. We created a technical information flow diagram (Figure 7) to analyze and understand what kind of technical documentation the different stakeholders use today. The technical information flow illustrates that the technical 2D drawings have a limited area of use; engineers create them, and the operational purchasers include them in the purchase orders to mechanical manufacturers. The mechanical manufacturers are dependent on receiving detailed design properties, and the only component able to illustrate this in the current workflow is the 2D drawing. For the rest of the workflow, less rich formats, such as assembly drawings and the current capacity of the 3D models are adequate.

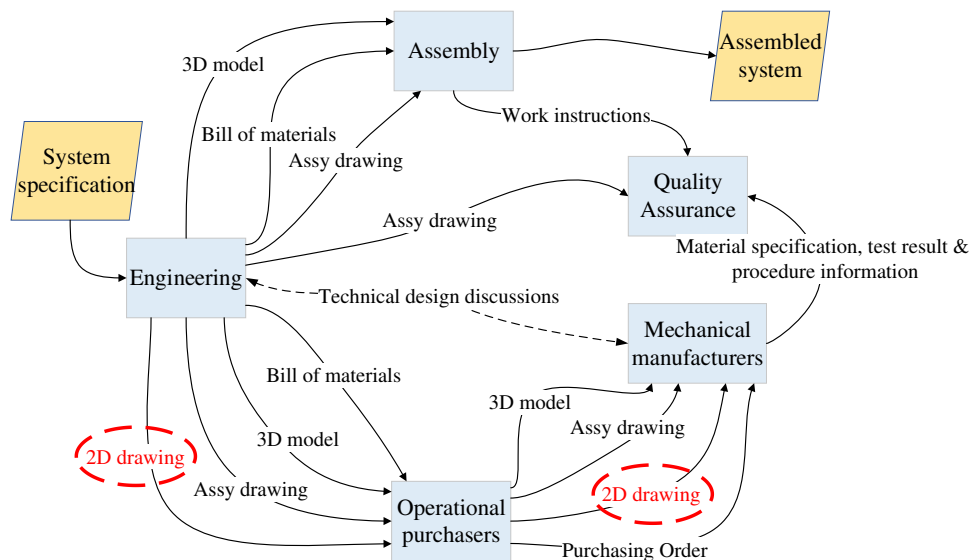

Figure 7. KDA's current technical information flow in industrial practice.

Work instructions. Today KDA uses photographs in combination with text to illustrate the assembly sequence to their operators. According to KDA, this can cause misinterpretation since people tend to understand text in different ways across the globe. An assembly operator in Norway could understand the work instruction differently from an assembly operator stationed in the United States. It is difficult to formulate text that is specific enough and unable to be misinterpreted in a local language or in the English language.

Re-iteration of the problem. KDA sees challenges and drawbacks with the current design process. The engineers are actively using 3D models when performing mechanical design. However, the handover artifact is a technical 2D drawing. We have formulated a new MBD process that would reduce non-value adding and time-consuming work.

Process review

The digital trend that we see today is here to stay, and if KDA wants to achieve a competitive position in the future, it is necessary to evolve with the trends. Automation is where development processes are now moving. One step on KDA's road toward automation and a digital work environment is the implementation of MBD. The objective of MBD is to reduce the time spent on design processes by shifting from traditional 2D drawings and going completely digital instead. The idea is that the 3D model is leading in every step of the design and manufacturing process (Cicconi et al., 2017). The engineers detail the design by adding annotations in the form of dimensions, tolerances and other remarks to the 3D model. This allows the 3D model to structure all the data regarding the properties

of the components and store them in one location. This is a big step forward compared to the current STEP format, since STEP files suffers from missing information.

Using MBD, the engineers can export the annotated 3D model as a native file, a 3D PDF. A portable document format (PDF) is a file format used for presenting documents that include text and images. The format is independent of software, hardware, and operating systems (Adobe, 2005). SolidWorks, which is the 3D modeling tool that KDA uses, has its own version of this as well, called an eDrawings file. Engineers can choose to generate either the SolidWorks standard eDrawings file or a 3D PDF. The low level of richness of the two is the same, i.e. receivers cannot change the content, as would be the case for source formats. Receivers can add comments in the form of text and lines that works as feedback to the constructors. In general, rich files belong in the engineering domain (designers, constructors) to ensure the quality of the design process and to control traceability and changes. Frozen files belong in the receiver domain (suppliers, mechanical manufacturers) where it is not possible to make actual changes to the models.

A native 3D PDF offers an insurance for the future compatibility of the information. PDFs are standard and not directly linked to a modeling software, which makes the users software-independent. One can argue that an eDrawings file adds value if SolidWorks is the computer-aided design software used by a company. On the other hand, it can disable the incorporation of other design tools that could serve as useful, since other tools could be unable to communicate with or open the eDrawings file.

These files can be accessed using desktop computers, iPads, or tablets, providing great flexibility (SolidWorks, 2017). Engineers and manufacturers can examine the model without the use of the 3D modeling software, since the eDrawings and 3D PDF files enable the possibility to rotate, show/hide specific components, and split views. The engineers can link other technical information that is required for manufacturing, support, and life-cycle management to these files (Alemanni et al., 2011).

Alemanni et al (2011) states that, if all customers and suppliers work with these files, then it would eliminate the need for translations between 3D and 2D, and the usual paperwork. This lets engineers fully focus on the design and development of new systems.

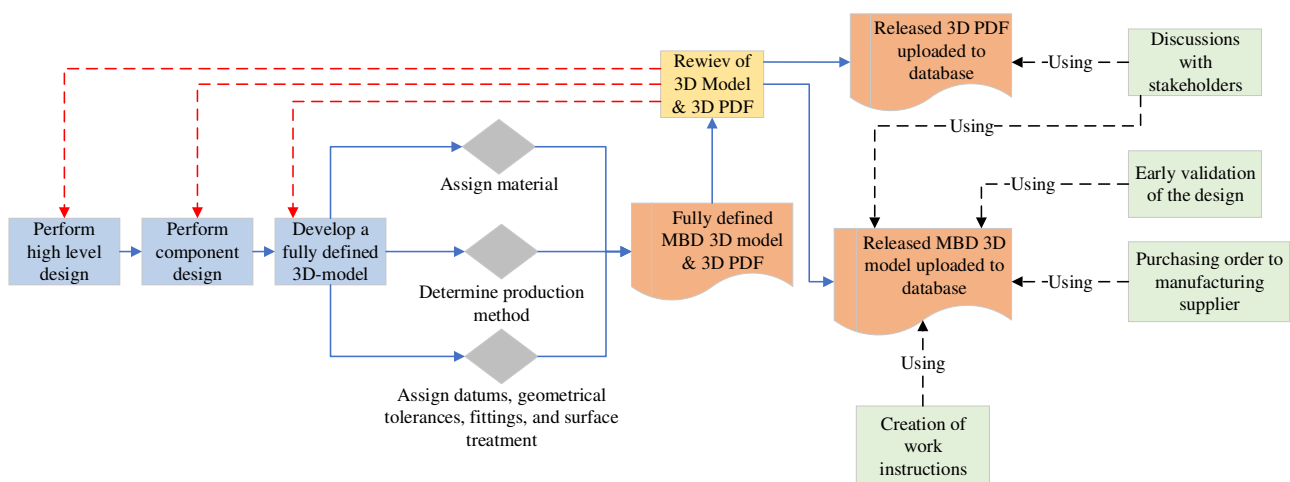

Figure 8. The envisioned mechanical development process.

Engineers can attach file notations and comments directly to a visualization of the model by using SolidWorks eDrawings or Acrobat Reader, This emphasizes one of the benefits that was exclusively provided by the 2D drawings in the past (SolidWorks, 2017). Engineers can perform design reviews and validation at an earlier stage with the 3D PDF file as a basis, since this format allows the examination of views, sections, and needed components separately. This is an important aspect since

errors that occur early in the design process are easier to fix, and the cost associated with this is significantly lower in comparison to fixing them in later phases of the development process (Walden et al., 2015).

The MBD approach is beneficial since it solves several of the drawbacks that standard 2D drawing process is struggling with. When creating technical 2D drawings for detailed and complex parts, engineers spend most of their time making sure every feature is fully dimensioned and every view fit on the sheet. MBD solves this automatically since this approach allows engineers to assign all technical information straight to the 3D model. The engineers' functional idea of the product can be difficult to express accurately on a piece of paper. This can be problematic when the product is in the workshop of the manufacturer. The inclusion of MBD files in the purchase order would help the mechanical manufacturers in their work. KDA and their mechanical manufacturers would be able to hold technical discussions related to the component and the detailed design at an earlier stage. The mechanical manufacturers are experts within their field and would be a great help to the engineers at KDA with their insights on different design solutions that are connected to lower manufacturing costs.

Active use of the 3D models when creating work instructions could reduce the misinterpretation that text brings. Figures and models function as a universal language that is easy to understand. Coloring, highlighting, and hiding specific components of the assembly is simple to do in 3D modeling software. This would make the work instruction robust and understandable by almost anyone.

The proposed process enables early review and validation of the design and includes a fully defined 3D model in purchase orders. Further, it allows technical discussions with stakeholders without the use of a 3D modeling software and emphasizing automation. These actions are taking place at an early stage of the design process, which according to Letho (2011), is where companies should put their improvement focus to increase the performance connected to quality, cost, and time-to-market.

Results

Technical documentation. We created new 3D models according to the MBD approach. Figure 9 illustrates the models related to the pilot project. The figure contains the azimuth manual release full assembly (III), an exploded view of the full assembly (V), and the base plate with tolerances, datums, and other technical information important to the design, assigned to the model (IV).

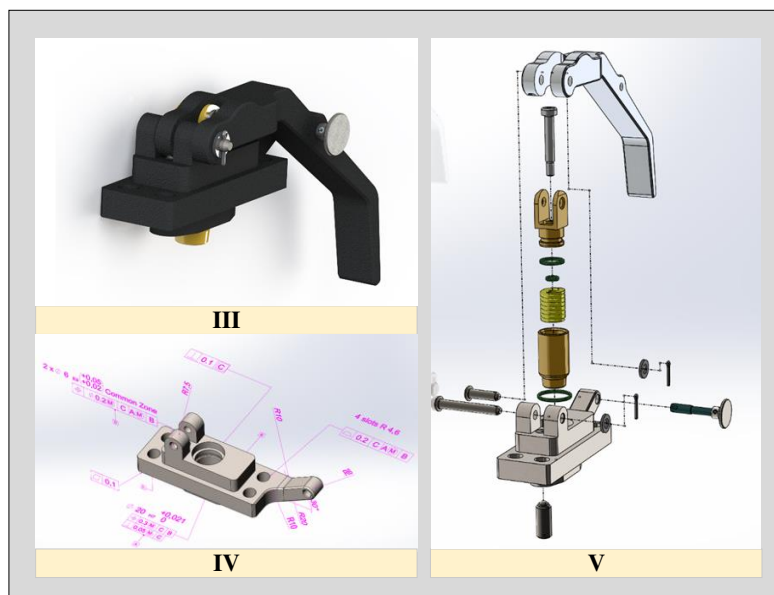

Figure 9. Illustration of the pilot project parts.

We created a template and generated a 3D PDF (Figure 10) of the base plate. The purpose of the 3D PDF is so that stakeholders who do not possess a SolidWorks license can examine the model. The 3D PDF includes the complete model with the important tolerances, technical manufacturing requirements, and a section where the users can submit comments. We created two pre-defined views of the component (top view and side view) that illustrate the most critical tolerances related to the model separately. The viewers can also rotate the model as desired to perform detailed examination. We generated the model and 3D PDF from the SolidWorks 2015 edition. Newer versions of the software include additional functionality in terms of traceability and revisions. This would make the solution more robust in terms of quality.

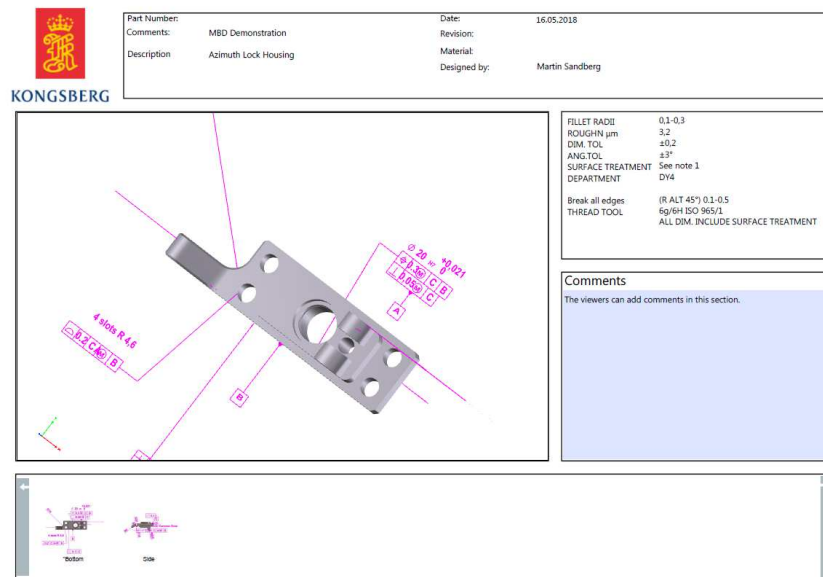

Figure 10. The 3D PDF generated by SolidWorks.

Mechanical manufacturers. We found that the exclusion of the technical 2D drawings would not generate major changes in the development process. During our interviews with the mechanical manufacturers, we discovered that they have limited use for the technical 2D drawings. They are ready to use the 3D model actively when programming their CNC machines. When the mechanical manufacturers later perform the component measuring process, the measuring machine is ready to use the MBD 3D models as a reference and does not require any manual input of reference data. The only occasion where they see a need for a technical 2D drawing today is when the component has low complexity and they manufacture it using a manual lathe. This finding points out that the mechanical manufacturers are, in general, ready for a transition to the MBD approach, and they possess the needed competencies. The mechanical manufacturers also stated that a fully defined 3D model would increase their understanding of the components.

When performing the research, we found that the STEP file is unable to fully represent tolerances. A STEP file is only able to understand and represent nominal tolerances. This creates issues when the mechanical manufacturers are to use the STEP file for the measurement process. In addition, it is impractical since the conversion of model formats between different CAD software is incapable of capturing specific model properties. If KDA and its mechanical manufacturers apply the automated MBD approach, then there is a need of a full SolidWorks version of the 3D model. This requires that the mechanical manufacturers use and have competence in SolidWorks as their CAD tool.

Work instructions. During our post-interviews with the assembly personnel, we found that they were positive toward a solution that emphasizes a digital format. Using the MBD approach, they would get a head start since MBD would give them fully defined 3D models at an earlier stage. MBD makes it possible to use these 3D models when creating documentation with the help of SolidWorks Composer, instead of photographs in combination with text that is the standard today. SolidWorks

Composer automatically synchronizes the documentation so that it corresponds with the latest revision in the case of a design change. Furthermore, the assembly personnel stated that work instructions completely built up by the 3D model would be a step forward in terms of providing an understanding of the system. The responsible personnel can assign different colors to the subcomponents of the assembly; clearly illustrating which part is the subject in the different assembly steps. This coloring maneuver, in combination with hiding irrelevant parts of the assembly, would increase the effectiveness of the work instructions and reduce the amount of text required. The fact that MBD makes the work instructions easier to understand reduces the risk that failures occur in production.

Engineering evaluation. Figure 11 illustrates the result of the questionnaire that the engineers at KDA responded to. We used a 5-point Likert scale to extract promoters and detractors, which enabled us to analyze the result using NPS. To consider a statement as good, the NPS must be > 0 .

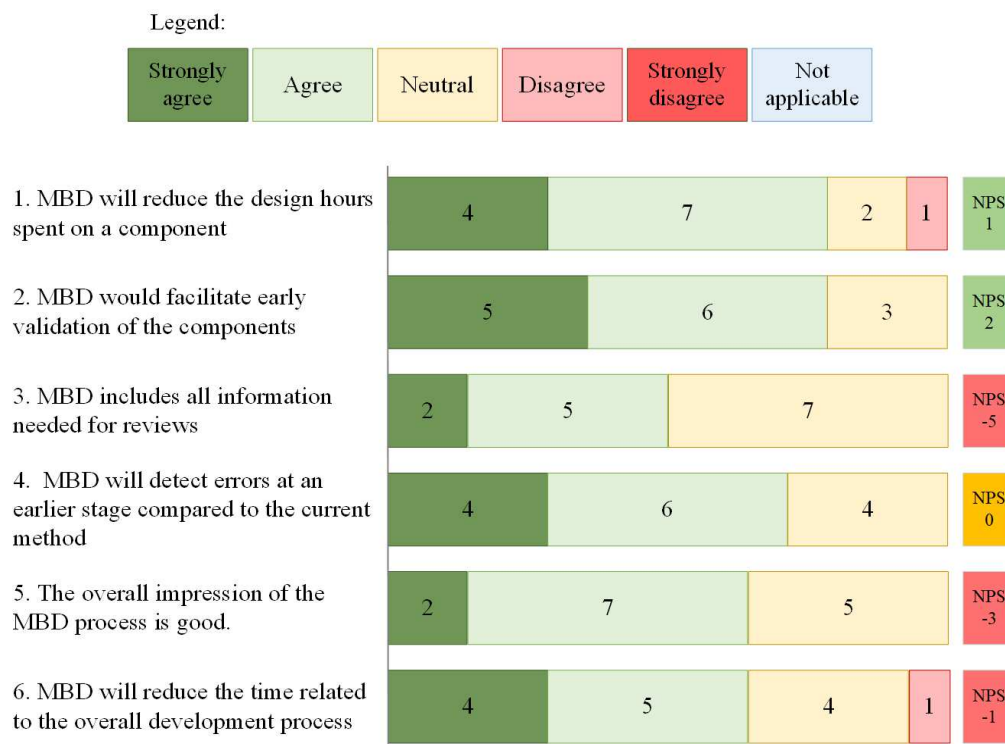

Figure 11. Questionnaire related to the MBD process.

The outcome of the questionnaire demonstrates that the engineers have mixed feelings and opinions regarding the MBD method. A positive aspect is the low portion of respondents answering “disagree” and “strongly disagree”. This indicates that the engineers are not strongly and fundamentally against the implementation of the MBD method. However, such a top-level analysis of the result is not adequate on its own. The NPS tells another story. There are only three of the six questions that have $NPS > 0$. This result points toward the need for additional efforts from KDA’s side to be able to implement the MBD method in an effective and structured manner. NPS suggests that the engineers only fully agree with two of the statements:

- MBD will reduce the time spent on a component.
- MBD would facilitate early validation of the components.

The statement relating to early detections of errors has an $NPS=0$, which is neither good nor bad. However, the respondents did only just select “strongly agree”, “agree”, and “neutral” as responses, which indicates that none of them have disagreeing opinions related to the statement. Overall, the proportion of “neutral” opinions is rather high. We expect that the reason behind this is that the engineers do not feel comfortable enough to have a strong opinion towards a method they have not seen in full-scale operation.

When asked to express their opinions regarding the benefits (Table 1a) and concerns (Table 1b) of using the method, the engineers highlighted several important comments.

Table 1a. The engineers' perspective regarding benefits of the MBD method.

Aspect	Benefits
Illustration and overview	<ul style="list-style-type: none"> - Illustrates components in an orderly and understandable manner to manufacturers and customers. - Provides better overview and understanding of the assemblies in the review process using 3D models. This should reduce the sources of errors related to design. - Provides a better understanding of the design among the engineering team. A 3D model can tell a greater story related to design decisions, which could boost the control of the functionality of the components and assemblies.
Quality	<ul style="list-style-type: none"> - Facilitates for early validation, which should imply the discovery of possible errors at an earlier stage. - Engineers can spend more of their time assuring a good design, instead of creating documentation. - Engineers can start conversations with the mechanical manufacturers at an earlier stage, which can increase the manufacturability of the components.
Cost and time	<ul style="list-style-type: none"> - Reduces time related to create technical documentation. This is especially good when dealing with complex designs. - Enables the operations and production departments to be involved early in the process. They can use fully defined 3D models when creating work instructions.

Table 1b. The engineers' concerns related to the MBD method.

Aspect	Concerns
Traceability and usability	<ul style="list-style-type: none"> - There can emerge issues related to revision traceability when mechanical manufacturers use fully defined 3D models. - The exchange of 3D model content with manufacturers due to software dependent models. - How well deals the method with changes on the models, and how to visualize them?
Process	<ul style="list-style-type: none"> - Training and adapting to the new process could be time consuming. - There is a need for a test in a larger scale for it to validate the method. - Fear of that the implementation is too big to handle in one sequence, and that the use of the one step at a time principle is necessary.
Quality	<ul style="list-style-type: none"> - The method must be able to address relations between tolerances in assemblies to avoid component collision.

A big benefit the engineers mentioned related to the method was that it brings a great overview and understanding to the review process. This would reduce the sources of errors linked to the design. This is a very important benefit, since Walden et al. (2015) highlight the big difference regarding cost to extract defects early versus late in the design process. The engineers also claimed that the MBD method would reduce time related to generate technical documentation, since it eliminates the need for a technical 2D drawing. This would allow them to focus more of their time on the functionality of the design. This is one of the top objectives of this study, and a cornerstone in the MBD philosophy. Finally, they mention that the method would allow them to discuss the design with mechanical

manufacturers at an earlier time. As stated earlier, the mechanical manufacturers are experts within their field of manufacturability and producibility. If the engineers could hear their opinions regarding design decisions earlier and adjust parts of the design accordingly, it would have a great impact on the time needed for manufacturing and the related cost.

The engineers expressed a need for a larger-scale test to validate and properly understand the method. This statement goes hand in hand with Booker's (2012) claim that a full implementation is necessary to validate the method regarding benefit and value. Further, they mentioned concerns related to the revision management of 3D models. To mitigate this, the engineers must use the revision feature included in SolidWorks. This would help them in terms of keeping track and assuring the use of correct models. Finally, they mentioned an opinion that often arises when dealing with the implementation of new processes: fear of the new processes being too comprehensive and effort consuming to implement. KDA can perform actions to reduce this concern. A thorough presentation and illustration of the new process applied to a full RWS system would serve as useful to increase the engineers' understanding of the concept further.

When asked about alternative solutions, the engineers mentioned STEP models combined with technical 2D drawings and the current process. We discuss the use of STEP models earlier in this paper. The main drawback with this solution is that the format is not rich enough. A STEP model is unable to represent tolerances and other design properties, thus eliminating the possibility for automated processes and independence from technical 2D drawings. We performed this study because the current process is ineffective, hence ruling out that option as a step forward.

Cost estimate. KDA needs several SolidWorks MBD licenses to start using the MBD approach. This is a cost they must incur to be MBD compatible. MBD is a plug-in to SolidWorks and a license costs NOK 19k plus an annual subscription fee of NOK 5k/year. In addition to the direct investment cost, there is cost related to the organizational implementation process that KDA must perform. KDA would reduce development time by eliminating the detailed 2D drawings; this would reduce cost as well. The time that MBD saves is worth more than the direct costs it incurs since engineers could spend their time working on other value-adding activities related to the design development. Therefore, MBD would boost the effectiveness of their work.

Cost versus value. A question that is common when the implementation of a new process is up for discussion is cost versus value. To be justifiable, a new process should add more value than it takes effort to implement and maintain. Value is hard to measure since it often consists of both hard and soft elements. One way to quantify value is to analyze in what degree the new process contributes to reduced risks. The most prominent risks associated with the current design process at KDA are late discovery of errors, mismatch between assemblies due to late validation, and mismatch of the technical 2D drawings and 3D models due to revision changes. We consider the occurrence of these aspects as critical since they impact KDAs overall goal to reduce time-to-market for new systems.

Since the new proposed process is based on the same competence as is current today, the need for courses and on-the-job training for the engineers is minimal. We expect that the cost related to the new process, most of it consisting of SolidWorks MBD licenses, is minor compared to the added value the new process will bring to KDA. This is based on the assertion that the MBD method will reduce the engineering hours required to design new systems due to a more effective work process, and that early validation of designs will reduce the late discovery of errors. With new working processes comes a time of transition. However, the change to including dimensions, geometrical tolerances, and datums to the 3D model instead of to technical 2D drawings, would not be problematic to perform.

Given this, we suggest that the value added is greater than the cost. We expect a clear benefit following an implementation of MBD.

Validity of the results. The MBD method is a comprehensive method to analyze and implement. A complicating fact is that it touches most of the design chain, which means that it is dependent on multiple stakeholders.

Alemanni et al. (2011) verifies our claim that an adoption of MBD by all parties in the design chain would save the time-consuming work of translating 3D models into technical 2D drawings. This reduces the workload of the engineers and let them solely focus on the design and development of new systems; an aspect that the engineers requested. We confirm this by our process mapping and evaluation with the engineers and other stakeholders to the design process.

Recommendations

In general, MBD complies with the predominant industry standards ISO, ASME, MIL, and DIN. We recommend that KDA perform further studies with the aim of identifying an effective manner of designing their technical documentation and the traceability of it to fulfill the requirements related to the standards.

Our findings imply that the value the MBD method would bring to the company is greater than the required effort to implement it. Widman et al. (2016) claim that an implementation of a digital design tool such as the MBD method is an investment well spent. Nevertheless, without a full implementation of the method and an analysis of it, we cannot validate such claims. Therefore, we see a need for a large-scale study, performed on a whole RWS system, to validate our results. An implementation of a process with this magnitude is complex with shifting elements, and as Booker's (2012) claims, there is a need for a full implementation for proper validation. Factors that do not affect small-scale projects can build momentum and increase regarding influence when transferred into a larger context.

Finally, we recommend KDA to create an architecture for its tool chain and processes. This architecture should establish a basis regarding which formats KDA should use for the information transfer.

Conclusion

The goal of this study was to analyze KDA and their suppliers regarding an implementation of MBD in terms of what competences and tools they need, what investments they must make, and what time and cost benefits they may expect. We did this by applying the MBD method to a sub-assembly of an RWS. We identified stakeholders, required technical documentation, and studied the current design and development for the mechanical components process to analyze cost and time-to-market drivers. Our research indicates that the MBD method could serve usefully in terms of cost and time-to-market reduction. The MBD method enables early validation and eliminates the need for technical 2D drawings. Due to this, MBD adds additional value since it reduces project risk. The effective way of work should reduce the engineering hours, as well; an aspect highly linked to cost. KDA would need to invest in new MBD licenses to utilize the method.

The process enables partial automation since mechanical manufacturers can use the rich and fully defined 3D model when programming CNC and measurement machines. However, working efficiently requires a rich 3D model. This entails that the mechanical manufacturers possess a SolidWorks license and competence in using the Software. The engineering domain required competences related to the MBD method are the same as the current process; the difference lies in when the engineer applies the data to the 3D model. Our proposed solution will reduce time-to-market and cost by streamlining KDAs overall design process, eliminating manual duplication of work, and enabling automated manufacturing.

Future research

There is a need for further analysis of what formats companies should include in the tool chain. The MBD method makes it possible to fill the 3D models with data in a unified and reusable format; elements that are of utmost importance of the design processes regarding time-to-market. The existing unified 3D model standard (STEP) does not incorporate rich data since the software transforms the content to a solid, or surface, model losing the feature tree. The feature tree is a necessity for creating a solid foundation for the implementation of MBD.

It is necessary to perform more research on how much time and cost savings engineering companies could expect from the MBD method. Given the short timeframe of this project, we could not obtain any hard data related to this. A full-scale case study performed over a longer period when data is available should be able to identify these aspects.

Acknowledgements

We would like to thank KDA, especially Ola Jacob Iversen for giving us the opportunity to perform the master thesis project with them.

Finally, we would like to thank Aleksander Kristoffersen, the industry Supervisor at KDA. Aleksander served as an excellent help when it came to identify the current way of work and to discuss the practical aspects of the case.

References

- Adobe. 2005. PDF reference : Adobe portable document format, version 1.6. Adobe portable document format, version 1.6. Peachpit Press.
- Alemanni, M., Destefanis, F. & Vezzetti, E. 2011. Model-based definition design in the product lifecycle management scenario. *The International Journal of Advanced Manufacturing Technology*, 52, 1-14.
- Booker, J. 2012. A survey-based methodology for prioritising the industrial implementation qualities of design tools. *Journal of Engineering Design*, 23, 507-525.
- Cicconi, P., Raffaelli, R. & Germani, M. 2017. An approach to support model based definition by PMI annotations. *Computer-Aided Design and Applications*, 14, 526-534.
- Jamieson, S. 2004. Likert scales: how to (ab)use them. *Medical Education*, 38, 1217-1218.
- KONGSBERG. 2017. Annual report and sustainability report [Online]. www.kongsberg.com. Available:
https://kongsberg.com/~media/KOG/Files/Investor/Annual%20reports/2017/KOG-A%CC%8Arsrapport-GB-interaktiv-web_ny.ashx?la=en [Accessed 16.04.2018].
- Lasi, H., Fettke, P., Kemper, H.-G., Feld, T. & Hoffmann, M. 2014. Industry 4.0. *The International Journal of Wirtschaftsinformatik*, 6, 239-242.
- Lehto, J., Harkonen, J., Haapasalo, H., Belt, P., Mottonen, M. & Kuvaja, P. 2011. Benefits of DfX in Requirements Engineering. *Technology and Investment*, Vol. 2 No. 1, 27-37.
- Muller, G. 2013. Systems Engineering Research Methods. *Procedia Computer Science*, 16, 1092-1101.
- Reichheld, F. F. 2003. The one number you need to grow. (the influence of customer word-of-mouth)(Cover Story). *Harvard Business Review*, 81, 46.
- Solidworks, D. S. 2017. SOLIDWORKS Technical Communications - Adding Innovation to your technical communication deliverables [Online]. Available:
http://www.solidworks.com/sw/docs/3DS_2017_SWK_TechnicalCommunications_Datasheet.pdf [Accessed 01.12.2017].
- Walden, D. D., Roedler, G. J., Forsberg, K., Hamelin, R. D., Shortell, T. M. & INCOSE 2015. *Systems engineering handbook : a guide for system life cycle processes and activities*, Hoboken, N.J, Wiley.

Widman, R., Hemphälä, J. & Ritzén, S. 2016. Investigating Model-Based Definition Implementation: A Case Study on Cross-Functionality through Product Lifecycle Management. KTH Royal Institute of Technology.

Biography



Martin Sandberg, born in Sweden, received his Master of Science in Systems Engineering with Industrial Economics from the University of South-Eastern Norway in 2018. He is currently employed as a Systems Engineer for Kongsberg Defence & Aerospace in Kongsberg, Norway.



Gerrit Muller, originally from the Netherlands, received his Master's degree in physics from the University of Amsterdam in 1979. He worked from 1980 until 1997 at Philips Medical Systems as system architect, followed by two years at ASML as manager systems engineering, returning to Philips (Research) in 1999. Since 2003, he has worked as senior research fellow at the Embedded Systems Institute in Eindhoven, focusing on developing system architecture methods and the education of new system architects, receiving his doctorate in 2004. In January 2008, he became full professor of systems engineering at University of South-Eastern Norway in Kongsberg, Norway. He continues to work as senior research fellow at the Embedded Systems Innovations by TNO in Eindhoven in a part-time position.

All information (System Architecture articles, course material, curriculum vitae) can be found at: Gaudí systems architecting <http://www.gaudisite.nl/>



Satyanarayana (Satya) Kokkula received his Master's degree in Applied Mechanics from IIT Delhi (Indian Institute of Technology, Delhi) in 2000. For one year (2001-2002), he worked as an Assistant Systems Engineer at TATA Consultancy Services Pune, India. In 2005, he received his PhD from the Norwegian University of Science and Technology (NTNU), Trondheim, Norway. After finishing PhD, he joined FMC Kongsberg Subsea AS as a Specialist Engineer in Structural Analysis from 2006 to 2016. In August 2017, he joined the University of South-Eastern Norway as an Associate Professor of Systems Engineering.