

FMH606 Master's Thesis 2020

Electrical Power Engineering

Design of a Low-Voltage High-Power DC Power Supply for Microbial Electrochemical Synthesis

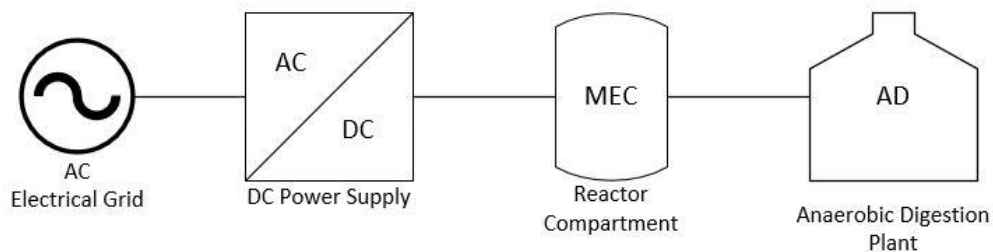

Vilde Sundling

Course: FMH606 Master's Thesis, 2020

Title: Design of a Low-Voltage High-Power DC Power Supply for Microbial Electrochemical Synthesis

Number of pages: 63 (61 + appendices)

Keywords: DC Power Supply, Unregulated Power Supply, Switching Power Supply, Low voltage, High power, Power loss, Efficiency, Commercial Power Supply

Student: Vilde Sundling
Supervisor: Kjetil Svendsen
External partner: Research/MES group at USN
Availability: Open

Summary:

This Master's Thesis is established to design an optimal low-voltage high-power DC power supply which can feed a biochemical system consisting of a microbial electrolysis cell, which further is connected to an existing anaerobic digestion plant. The complete system is called a bioelectrochemical system, where the purpose is to increase the amount of methane by reducing the amount of carbon dioxide in the biochemical system.

The objectives for the thesis are mainly to design a power supply that can be used for a laboratory scale setup. In addition, a minor evaluation of the scalability for a larger pilot setup will be performed, as well as an investigation of the availability of commercial power supplies suitable for a laboratory scale system.

There have been performed several methods to obtain the goal of the thesis, including a literature review, and modelling and simulation of different power supply models in Simulink.

The thesis concludes that a switch mode DC power supply would be a proper choice to implement in the bioelectrochemical system due to a high efficiency around 90 %, and with great regulation opportunities. More precisely, the design of the half-bridge DC-DC converter with electrical isolation, which had a series configuration, will be the recommended choice for an optimal low-voltage high-power DC power supply which can be connected to the biochemical system.

Preface

This Master's Thesis is a result of the final project regarding the Master of Science in Electrical Power Engineering at the University of South-Eastern Norway in Porsgrunn. The thesis is written in the final semester in spring 2020.

I would like to thank my supervisor Kjetil Svendsen for valuable guidance and support during the semester.

Porsgrunn, 15.05.2020

Vilde Sundling

Contents

Preface	3
Contents.....	4
Nomenclature	6
1 Introduction	7
1.1 Background	7
1.2 Overview of the Thesis.....	8
1.2.1 <i>Task Description</i>	8
1.2.2 <i>Methods</i>	8
1.3 Objectives.....	8
1.4 Limitations.....	8
1.5 Report Structure	9
2 System Description.....	10
2.1 Overview of the Complete System.....	10
2.2 Specifications Regarding the Power Supply to the MEC	10
3 Theory	12
3.1 Unregulated DC Power Supply	12
3.1.1 <i>Transformer + Rectifier</i>	12
3.2 Switching DC Power Supplies.....	12
3.2.1 <i>Step-Down (Buck) DC-DC Converter</i>	12
3.2.2 <i>Half-Bridge DC-DC Converter with Electrical Isolation</i>	13
3.2.3 <i>PWM Control of Switching DC Power Supplies</i>	14
3.2.4 <i>Switch Utilization in DC-DC Converters</i>	15
4 Modelling and Simulation of a DC Power Supply.....	17
4.1 Introduction	17
4.2 Common Components for the Power Supply Models in Simulink	17
4.2.1 <i>Diode</i>	17
4.2.2 <i>Transformer</i>	18
4.2.3 <i>Switch</i>	19
4.3 Three-Phase Diode Rectifier Connected Directly	20
4.3.1 <i>Model Setup</i>	20
4.3.2 <i>Working Principle of the Rectifier Model</i>	22
4.3.3 <i>Generated Output Values from Simulation</i>	23
4.3.4 <i>Power Loss and Efficiency of the Rectifier Model</i>	24
4.3.5 <i>Variation in AC Supply Voltage to the Power Supply</i>	27
4.3.6 <i>Discussion</i>	28
4.4 Three-Phase Diode Rectifier Sectioned and Connected in Series	28
4.4.1 <i>Model Setup</i>	28
4.4.2 <i>Working Principle of the Rectifier Model</i>	29
4.4.3 <i>Generated Output Values from Simulation</i>	29
4.4.4 <i>Power Loss and Efficiency of the Rectifier</i>	30
4.4.5 <i>Variation in AC Supply Voltage to the Power Supply</i>	32
4.4.6 <i>Discussion</i>	33
4.5 Half-Bridge DC-DC Converter - Sectioned and Connected in Series	34
4.5.1 <i>Model Setup</i>	34
4.5.2 <i>Working Principle of the Half-Bridge Converter Model</i>	36

4.5.3 Generated Output Values from Simulation 38

4.5.4 Power Loss and Efficiency of the Half-Bridge Converter 39

4.5.5 Variation in AC Supply Voltage to the Power Supply..... 41

4.5.6 Discussion 41

4.6 Half-Bridge DC-DC Converter with Electrical Isolation - Sectioned and Connected in Series 43

4.6.1 Model Setup..... 43

4.6.2 Working Principle of the Half-Bridge Converter Model..... 45

4.6.3 Generated Output Values from Simulation 48

4.6.4 Power Loss and Efficiency of the Half-Bridge Converter 49

4.6.5 Variation in AC Supply Voltage to the Power Supply..... 51

4.6.6 Discussion 52

5 Commercial DC Power Supplies Suitable for a Laboratory Scale System 53

5.1 Research of Availability Regarding Different Output Values 53

5.2 DC Power Supply Examples for Output Values of 24 V and 100 A..... 54

5.2.1 Mean Well RSP-2400-24..... 54

5.2.2 Artesyn LCM3000Q-T..... 55

5.3 Discussion 55

6 Discussion 56

6.1 Main Discussion..... 56

6.2 Evaluating the Scalability for a 100 kW Pilot Setup 57

7 Conclusion 58

7.1 Main Conclusion 58

7.2 Further Work 59

References 60

Appendices 62

Nomenclature

Abbreviation	Explanation
AC	Alternating current
AD	Anaerobic digestion
CH ₄	Methane
CO ₂	Carbon dioxide
DC	Direct current
Lab	Laboratory
MEC	Microbial electrolysis cell
MES	Microbial electrochemical synthesis
PWM	Pulse-width modulation
USN	University of South-Eastern Norway

Symbol	Unit	Explanation
A	m ²	Area
D	%	Duty ratio/cycle
I	A	Current
η	%	Efficiency
P	W	Power
R	Ω	Resistance
V	V	Voltage

1 Introduction

This chapter gives an introduction to the Master's thesis, and contains background information for why the thesis was established, an overview of the thesis and its aim, objectives, limitations and how the report is structured.

1.1 Background

To reduce the use of fossil oil and gas it is beneficial to locate other solutions that can be used as fuel or other building blocks for new products. Hydrogen and methane are examples of valuable products that can be used to generate electricity.

One way to obtain hydrogen and methane are through biomass production which is further processed in bioelectrochemical systems (BES). BES is divided into several concepts, and a microbial electrolysis cell (MEC) is used in this case. An external voltage is then applied to the circuit to produce the valuable products, in this case to increase valuable methane output and reduce harmful carbon dioxide output. A more specific technology that treats the particular topic, where carbon dioxide (CO_2) can be reduced to methane (CH_4), is a microbial electrochemical synthesis (MES) which is a power to gas technology. [1] [2] [3]

The research group for the biochemistry field at the Department of Process, Energy and Environmental Technology at the University of South-Eastern Norway (USN) has conducted experiments where the goal was to obtain a biogas upgrading of biogas produced by treatment plants to increase the content of methane. It was obtained in such way that biogas CO_2 was reduced to methane through a methane-producing microbial electrolysis cell (MEC).

Before the upgrading of the biogas content, the gas composition was 65 % CH_4 and 35 % CO_2 . Therefore, the research group wants to upgrade the content of methane further, and an optimal solution can achieve a gas composition of 90 % CH_4 and 10 % CO_2 according to the research group. It means that the optimal solution is to increase the content of CH_4 by 25 % and to decrease the content of CO_2 by 25 %.

To obtain an optimal solution for the biogas upgrading, it is preferable to have an optimal power supply which can provide the biochemical system (consisting of a MEC in a reactor compartment which is connected to an anaerobic digestion (AD) plant) with power such that the system can perform as desired. Together it is called a bioelectrochemical system.

Therefore, this master's thesis is established to design an optimal DC power supply to the biochemical system.

1.2 Overview of the Thesis

1.2.1 Task Description

The aim of the thesis is to design an optimal low-voltage high-power DC power supply to a microbial electrolysis cell which is connected to an existing anaerobic digestion plant. The DC power supply should be designed such that it fulfills the requirement for the bioelectrochemical system in the laboratory at the University of South-Eastern Norway.

The main focus is to design a DC power supply that can be used in a laboratory scale setup. Furthermore, the scalability of a larger pilot scale setup will be evaluated from the found solution for a laboratory setup.

In addition to the design and evaluation of different power supply setups, it is of interest to investigate whether any commercial power supplies would be suitable for a laboratory scale setup.

1.2.2 Methods

Several methods are performed to obtain the goal of the thesis. Literature review is one method which is performed to get an overview of different types of DC power supplies and to understand their function. Modelling and simulation are other methods which are performed to obtain simulation results which can be utilized for the design of the power supply. The MATLAB-based graphical program Simulink is used to model and simulate the system.

1.3 Objectives

To fulfill the aim of the thesis, the following objectives will be performed:

- Literature research into the most common types of power supply solutions
- Modelling and simulation of different power supply solutions
- Design of a power supply that can be used for a laboratory setup
- Investigate critical building blocks for the laboratory scale power supply
- Investigate availability of commercial power supplies suitable for this application
- Evaluate the scalability of the found solution for a 100 kW pilot setup
- Estimate the energy efficiency for different solutions, such as at different voltage levels

The original problem description is given in Appendix A.

1.4 Limitations

Several limitations will be presented in the items below to restrict the content in the thesis. The limitations are:

- The thesis will only focus on power supply solutions in the bioelectrochemical system
- The thesis will not look further into the bio- and chemical part of the system
- The thesis will focus on having 2 V per cell with regard to the range of 1-3 V

1.5 Report Structure

The Master's thesis consists of seven chapters which will be presented below:

Chapter 1: Introduction – Presents the background and overview of the thesis, as well as objectives and limitations.

Chapter 2: System description – Presents the description of the complete system regarding the DC power supply and relevant data regarding the design of the power supply.

Chapter 3: Theory – Presents the relevant theory regarding the thesis.

Chapter 4: Modelling and simulation of a DC power supply – Presents the modelling and simulation of different types of DC power supplies. Each subchapter of the power supply models consists of a model setup, working principle, generated output values, power loss and efficiency, variation in AC supply voltage, and a discussion of the models.

Chapter 5: - Presents a research of the availability of commercial DC power supplies suitable for a laboratory scale system.

Chapter 6: Discussion – Presents the main discussion of the thesis, as well as an evaluation of a 100 kW pilot setup.

Chapter 7: Conclusion – Presents the main conclusion of the thesis, as well as suggestions to further work.

2 System Description

This chapter contains a description of the complete system which the DC power supply is connected to, as well as specifications regarding different setups in case of the size for each setup.

2.1 Overview of the Complete System

An overview of the complete system regarding the thesis can be seen in Figure 2.1. The figure shows that the DC power supply will be provided by an electrical grid with an AC voltage, where the AC voltage further will be converted to a DC voltage within the power supply. The AC voltage from the mains/supply voltage will be set to be 400 V AC (line voltage), but other standard line voltages may be evaluated in further work. The DC power supply will further provide the microbial electrolysis cell (MEC) with a current and a voltage which will be defined by specifications from the research team regarding the need of supply to the MEC. However, the MEC will be placed in a single reactor compartment with multiple electrodes, where the MEC is further connected to an existing anaerobic digestion (AD) plant.

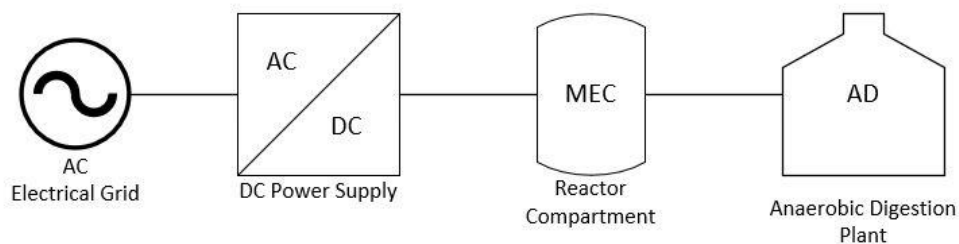

Figure 2.1: Overview of the complete system

2.2 Specifications Regarding the Power Supply to the MEC

The client for this thesis, which is the research group for the biochemistry field at USN, has given some indications for what the power supply should provide to the biochemical system, consisting of the MEC and AD, such that the biochemical system could perform as desired. There are three different setups regarding the size of the system, which can be categorized in a small scale system, a laboratory (lab) scale system, and a pilot scale system. The three setups with its respective values can be seen in Table 1, where the respective values are input values or values regarding the biochemical system, which is voltage, current density, anode area, current and power. It means that the input values of the voltage, current and power into the biochemical system similarly is the output values of the DC power supply. It is to be noted that the values are DC values, and that the power supply itself is connected directly to the system with the respective values given in Table 1. The biochemical system should have an input of a constant DC voltage such that the system will perform properly and have a predictable power supply to the system.

2 System Description

However, as the research group has conducted some experiments, they have also estimated how the methane production will increase by different current and setup. For the values given for the laboratory scale in Table 1, the methane production is estimated to increase by 5 %. For the values given for the pilot scale in the table, the methane production is estimated to increase by 10 %.

Table 1: Shows different values which were defined by the research group regarding each setup type for the bioelectrochemical system

Setup	Voltage [V]	Current density [A/m ²]	Anode area [m ²]	Current [A]	Power [W]
Small scale	1-3	2.5	0.003	$7.5 * 10^{-3}$	$(7.5 - 22.5) * 10^{-3}$
Lab scale	1-3	2.5	400	1000	1000-3000
Pilot scale	1-3	2.5	20000	50000	50000-150000

One problem the research group seemed to have is due to production of biofilm on the electrodes during the experiments, where the group has discussed that the system may need two voltage levels during the operating process. It indicates one voltage level in the start-up phase and a higher voltage level in the operating phase. This is an additional requirement from the group, and will be commented but is not the main focus in the thesis.

3 Theory

This chapter contains relevant theory regarding the thesis, which includes theory of unregulated DC power supplies and switching DC power supplies.

3.1 Unregulated DC Power Supply

Unregulated DC power supply is referred to as a power supply or converter where the output voltage is given directly by the circuit and the supplied voltage. This subchapter contains a simple power supply model.

3.1.1 Transformer + Rectifier

A circuit with a transformer and a rectifier is a simple converter topology of a DC power supply. Figure 3.1 shows an illustration of the converter topology. The figure illustrates that the converter will be supplied from the AC mains which is sent through a transformer to either step down or step up the voltage. The transformer is further connected to a rectifier bridge which will convert the AC voltage to a DC voltage which gives the output of the converter. [4]

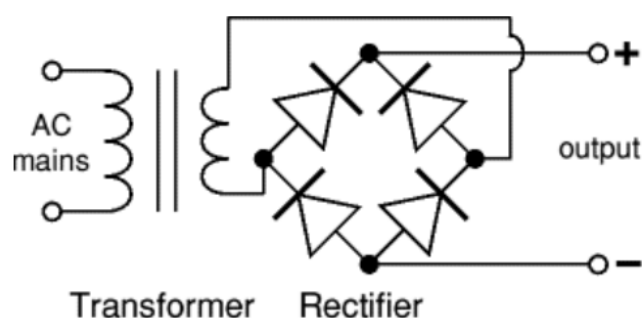

Figure 3.1: Illustration of an unregulated DC power supply including a transformer and a rectifier [4]

3.2 Switching DC Power Supplies

Switching DC power supply is referred to as a switch-mode DC-DC converter. This subchapter contains relevant DC-DC converters for the thesis, as well as PWM control and switch utilization regarding a switching power supply.

3.2.1 Step-Down (Buck) DC-DC Converter

A step-down converter, also called a buck converter, is referred to as a basic converter topology, where the purpose is to step down and produce a lower output voltage than the input voltage to the converter. The buck converter is a DC-DC converter since it steps down a DC input voltage to a DC output voltage. Figure 3.2 shows the topology of a buck converter, where it can be seen that the output circuit has a low-pass filter consisting of an inductor and a

capacitor. This is due to that the output voltage usually will alternate between zero and V_d . However, the voltage will then be filtered and damped by the low-pass filter. In addition, also the switching frequency ripple in the output voltage will be filtered and eliminated by choosing the corner frequency of the low-pass filter to be significantly lower than the switching frequency. [5]

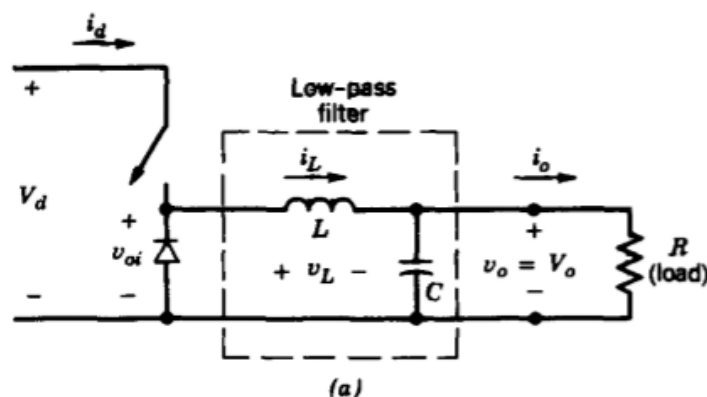

Figure 3.2: Step-down (buck) converter topology [5]

The average output voltage can be calculated in terms of the input voltage and the duty ratio of the switch, and is then given by

$$V_o = DV_d \quad (3.1)$$

where V_o is the DC output voltage, V_d is the DC input voltage, and D is the duty ratio of the switch.

The buck converter is often derived into other converter topologies depending on the purpose of the converter, and one of its main application areas are in DC power supplies. [5]

3.2.2 Half-Bridge DC-DC Converter with Electrical Isolation

A half-bridge DC-DC converter is derived from a step-down (buck) converter and has some essential modifications as seen in Figure 3.3. The half-bridge converter can, unlike the buck converter, either produce an output voltage which is higher or lower than the input voltage. It is still a conversion between a DC input voltage and a DC output voltage, while the DC input voltage may be unregulated and the DC output should be at a controlled voltage level.

One application area for a half-bridge converter is in DC power supplies, which may be connected to the mains where the AC voltage will be rectified and give an unregulated DC input to the converter. As seen in Figure 3.3, the half-bridge converter has a transformer in the circuit which is due to electrical isolation. DC power supplies may require having the output electrically isolated from the input/the mains, which is due to component protection and safety for the personnel regarding the output side of the converter. [5]

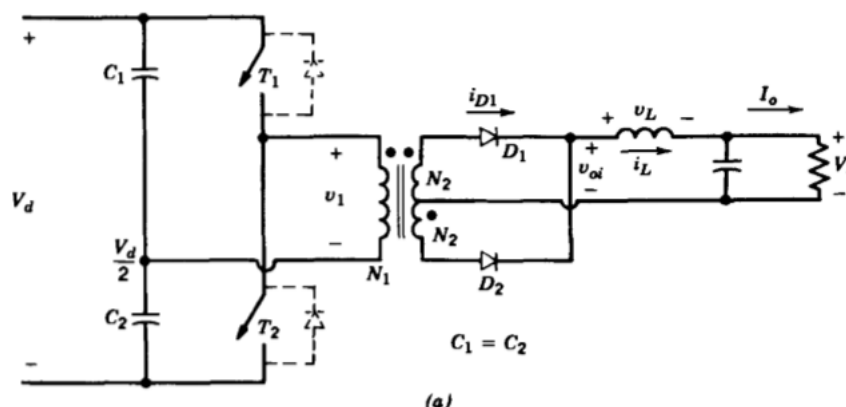

Figure 3.3: Half-bridge DC-DC converter topology with electrical isolation [5]

The average output voltage can be calculated in terms of the input voltage, the duty ratio of the switches and the transformer winding turns ratio, and is then given by

$$V_o = \frac{N_2}{N_1} D V_d \quad (3.2)$$

where V_o is the DC output voltage, V_d is the DC input voltage, D is the duty ratio of the switches, N_1 is connected to the primary winding, and N_2 is connected to the secondary winding. [5]

3.2.3 PWM Control of Switching DC Power Supplies

To control the DC output voltage of a switching DC power supply to obtain a desired voltage level, a method called pulse-width modulation (PWM) is generally used. The PWM method involves to control and adjust the duration time of a switch (or switches) in a power supply to control the output voltage level. The duration time of a switch is referred to as the duty ratio or duty cycle when the switch is ON compared to the switching time period. It is to be noted that the PWM method includes that the switching occurs at a constant frequency, which refers to a constant switching time period (where $T_s = t_{on} + t_{off}$).

The PWM signal needs to be generated, and this is performed by a comparison of a control voltage signal with a repetitive waveform like a sawtooth waveform. It is the sawtooth waveform that establishes the switching frequency. Figure 3.4 shows how the PWM signal (called switch control signal in the figure) is generated with the comparison of the sawtooth voltage, v_{st} , and the control voltage signal, $v_{control}$. [5]

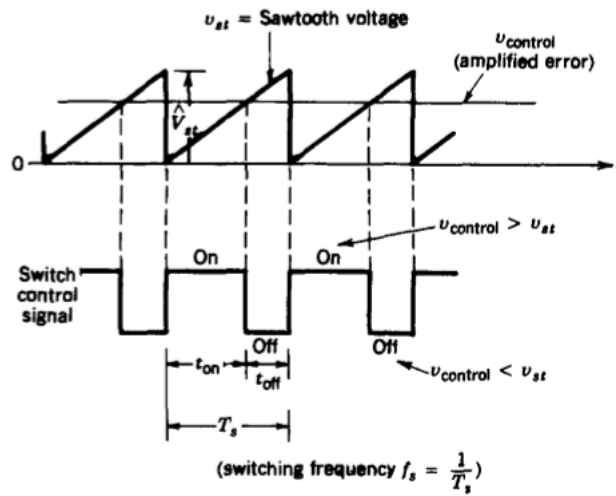

Figure 3.4: Generated pulse-width modulation (PWM) signal from a sawtooth wave compared with a control voltage [5]

3.2.4 Switch Utilization in DC-DC Converters

Switch utilization is important to see how a switch is utilized during a time period of switching. Figure 3.5 shows the switch utilization of several DC-DC converters comparing the switch utilization factor against the duty ratio, D .

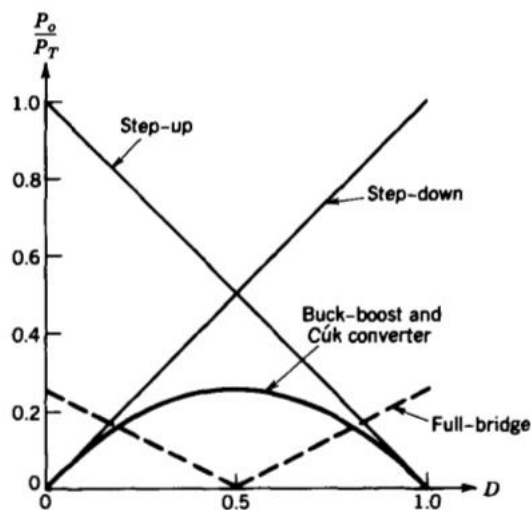

Figure 3.5: Switch utilization in DC-DC converters [5]

The switch utilization factor is given by

$$K_{sw} = \frac{P_o}{P_T} \quad (3.3)$$

where K_{sw} is the switch utilization factor, P_o is the rated output power, and P_T is the rated switch power.

It can be shown from Figure 3.5 that the switch utilization in a step-down (buck) converter is significantly high if the duty ratio has a long on time period, and similarly that the switch utilization is significantly low if the duty ratio has a short on time period. The half-bridge converter will be compared for the same line as for the step-down in the figure. [5]

4 Modelling and Simulation of a DC Power Supply

This chapter contains modelling and simulation of different types of DC power supply models. It includes two three-phase diode rectifiers with different configuration, a simpler version of a half-bridge DC-DC converter, and a half-bridge DC-DC converter with electrical isolation.

Each of the subchapters, which contain the different power supply models, are divided into the model setup, their working principle, generated output values from simulation, power loss and efficiency of the model, variation in the mains/AC supply voltage, and a discussion of the model in the end of each subchapter.

4.1 Introduction

Modelling and simulation are an important part of the thesis to make an optimal design of a power supply. Different solutions will be built, tested, and simulated in the MATLAB-based graphical program Simulink, as mentioned in subchapter 1.2.2. The models are based on power electronic components and other electrical components, and to manage these components in Simulink, two libraries called Simscape and Simscape Electrical were installed for this purpose.

The next subsections will consider different solutions of a power supply and it will be discussed whether the solution will be beneficial or not with the desired biochemical system. It is to be noted that the different solutions of a power supply will be modelled and simulated for a laboratory scale setup, and are based on the values for a lab scale in Table 1.

The Simulink models will be based on different DC converter models which are described in the theory in chapter 3.

4.2 Common Components for the Power Supply Models in Simulink

There are several components in the Power Supply models in Simulink which are common and will use the same values regarding the component if nothing else is given in this chapter. All the mentioned components in this subchapter can be found in the Simulink library: Simscape Electrical.

4.2.1 Diode

The diode component which is applied in several power supply circuits in this chapter can be seen in Figure 4.1. The diode is a semiconductor device where a DC voltage source is connected in series with a resistor and a switch, where its internal voltage and current will control whether the diode will conduct or turn off.

Default values of the diode component in Simulink will be used, which correspond to an internal resistance, R_{on} , of 0.001 ohms and a forward voltage, V_f , of 0.8 V. [6]

4 Modelling and Simulation of a DC Power Supply

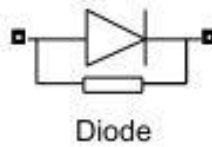

Figure 4.1: Simulink component of the applied diode

4.2.2 Transformer

The three-phase linear transformer component which is applied in the diode rectifier circuits in this chapter can be seen in Figure 4.2. The transformer consists of three single-phase, two-winding linear transformers, and has 12 terminals. [7]

Component values for the transformer in the rectifier circuits are not default values, but the majority of the values are the same. The rated power equals 10 MVA, the frequency equals 50 Hz, and the magnetizing branch has a resistance of $200 \cdot 10^6$ pu and a reactance of $200 \cdot 10^6$ pu. The resistance and reactance values of the windings are set to zero as it is added connected resistors on the outside of the transformer. Winding voltages will be defined in the subchapters of the diode rectifier circuits.

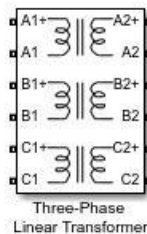

Figure 4.2: Simulink component of the applied three-phase linear transformer

Further, the three windings linear transformer component which is applied in the half-bridge DC-DC converter with electrical isolation circuit in this chapter can be seen in Figure 4.3. The transformer consists of three windings which are coupled and wound on the same core. [8]

Component values for the transformer are default values which is automatically generated to correspond to manually applied winding voltages. The voltage of winding 1 equals 200 V, while the voltage of winding 2 and 3 equals 40 V. The frequency is also changed to 50 Hz.

4 Modelling and Simulation of a DC Power Supply

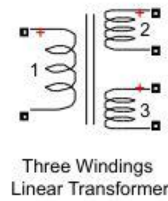

Figure 4.3: Simulink component of the applied three windings linear transformer

4.2.3 Switch

The MOSFET switch component which is applied in the half-bridge DC-DC converter circuits in this chapter can be seen in Figure 4.4. The switch is a metal-oxide semiconductor field-effect transistor (MOSFET) device where the switch is connected in series with a resistor and in parallel with an internal diode. It is an ideal switch component.

Default values of the switch component in Simulink will be used, which corresponds to an internal resistance, R_{on} , of 0.1 ohms, an internal diode resistance, R_d , of 0.01 ohms, and an internal diode forward voltage, V_f , of 0 V. [9]

It is to be mentioned that the switches in the circuits will be measured for conduction losses, while the switching losses will not be taken into account due to lack of methods for how to measure it in Simulink.

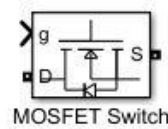

Figure 4.4: Simulink component of the applied MOSFET switch

4.3 Three-Phase Diode Rectifier Connected Directly

The first power supply model which is modelled and analyzed in Simulink is a three-phase diode rectifier which is connected directly to the desired biochemical system. Based on Table 1 for a laboratory scale system, the desired input values for the biochemical system have a voltage of 1-3 V and a current of 1000 A. The values which will be used as desired output values in the simulation of the diode rectifier have a voltage of 2V and a current of 1000 A, which gives the output power of the power supply to be 2000 W.

For this power supply model, it is the transformer that will be adjusted, due to its voltage ratio, such that the output voltage will gain its desired value, as well as the current and the power will gain its values.

4.3.1 Model Setup

The model setup for the three-phase rectifier model in Simulink can be seen in Figure 4.5. It consists of a three-phase AC voltage source, a three-phase transformer with connected resistors (which will later represent the losses in the transformer), a diode bridge used as a rectifier, a resistor as the cable, and a resistor at the end as the load.

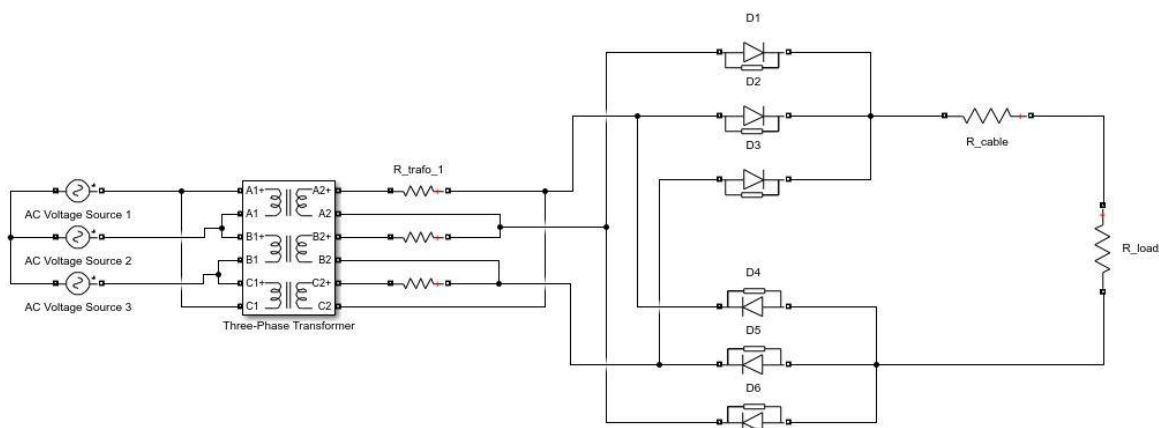

Figure 4.5: Three-phase diode rectifier model in Simulink

The complete model setup with measurements of voltage, current and power of all the components in the circuit can be seen in Figure 4.6.

4 Modelling and Simulation of a DC Power Supply

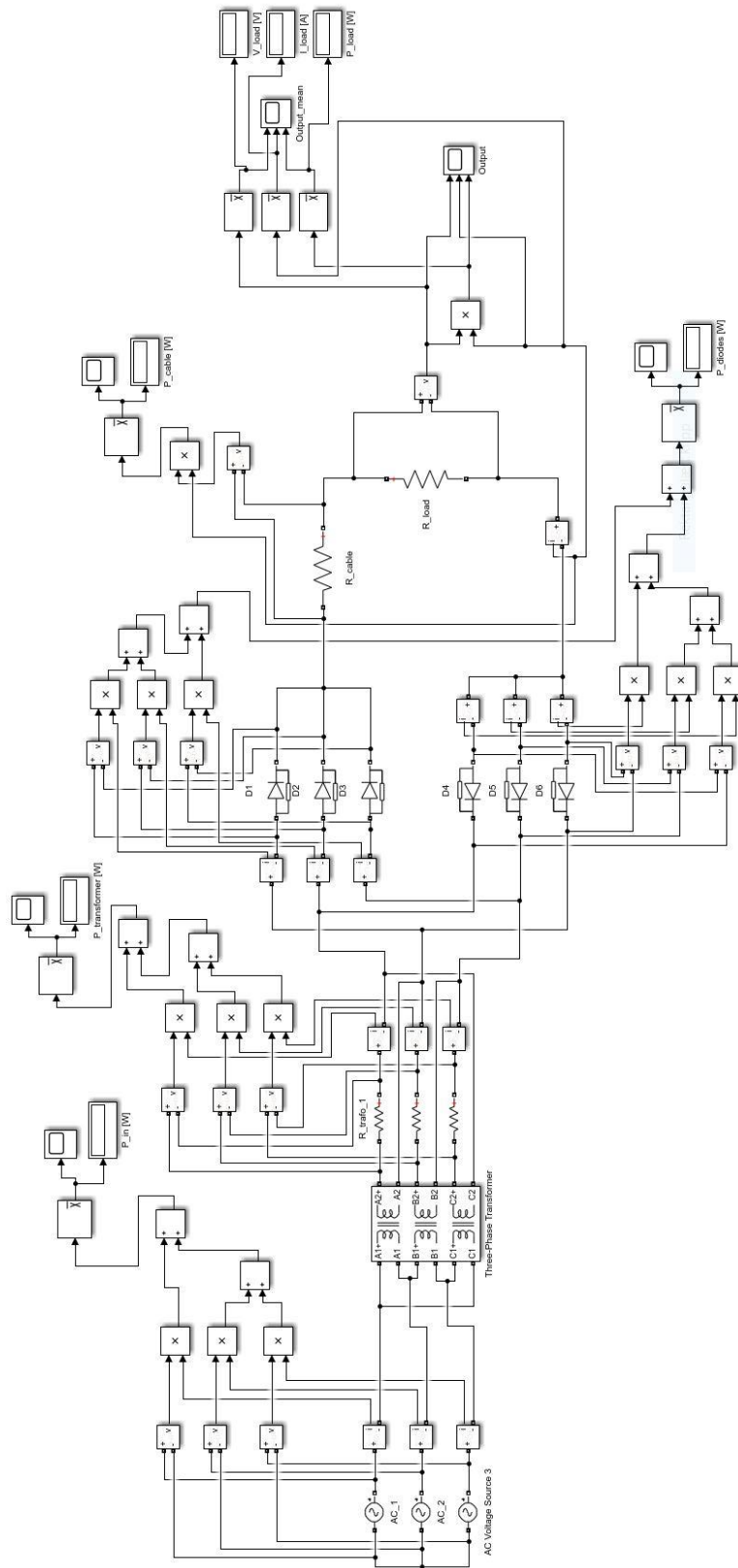

Figure 4.6: Complete model setup for the diode rectifier including measurements of the components in Simulink

4 Modelling and Simulation of a DC Power Supply

4.3.2 Working Principle of the Rectifier Model

The aim of this rectifier model is to rectify the incoming AC supply voltage such that the output of the circuit will be a DC voltage at a desired voltage level which will be connected to the biochemical system.

The incoming AC supply voltage, which can be seen in Figure 4.7, is a three-phase voltage supply where each of the voltage sources have a phase shift of 120 degrees. AC voltage source 1 is at 0 degrees, the second voltage source has a phase shift of 120 degrees and the third voltage source has a phase shift of 240 degrees. Each of the voltage sources has a phase voltage of 230 V, which is due to that the line voltage is set to be 400 V and the voltage sources is connected in a star configuration.

The AC voltage sources will supply the transformer, where the transformer further transforms the voltage to a lower level such that it will fit to the desired output values. The transformer is a three-phase transformer with 12 terminals and is constructed in such way that it consist of three single-phase, two-winding transformers, which can be seen in Figure 4.7. Three resistors are connected to the transformer, where these resistors belong to the resistance values of the transformer and will later represent the losses in the transformer.

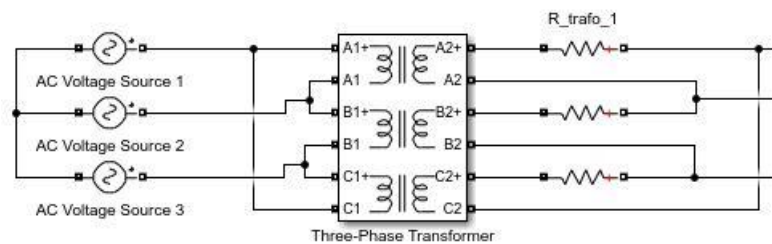

Figure 4.7: Left part of the rectifier model, here with the three-phase AC voltage supply and the transformer connected with resistors

When the transformer has transformed the voltage to a lower level, the AC voltage will be sent through a diode bridge as seen in Figure 4.8. The diode bridge is a three-phase rectifier consisting of 6 diodes which converts the AC voltage to DC voltage.

Between the diode bridge and the load it will be a power cable which will transfer the DC voltage (and the current) to the load. The power cable is referred to as R_{cable} in the circuit. At the end of the circuit there is a load, referred to as R_{load} , which is the part where the power supply will be connected with the biochemical system to supply voltage and current.

4 Modelling and Simulation of a DC Power Supply

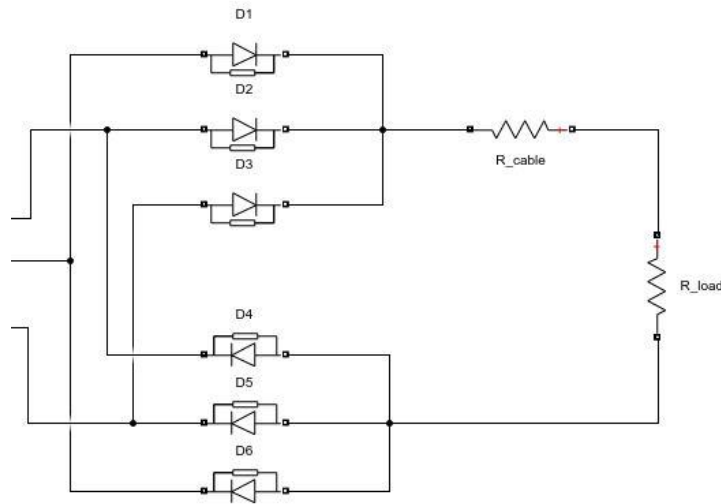

Figure 4.8: Right part of the rectifier model, here with the diode bridge, the resistor which belongs to the cable and the resistor which belongs to the load

4.3.3 Generated Output Values from Simulation

The rectifier model has desired output values of 2 V and 1000 A, as specified in Table 1 for the laboratory scale setup. The generated output values from the simulation of the rectifier model in Simulink can be seen in Figure 4.9. The measured mean values have an output voltage, V_{load} , of 2 V, an output current, I_{load} , of 1000 A, and an output power, P_{load} , of 2001 W.

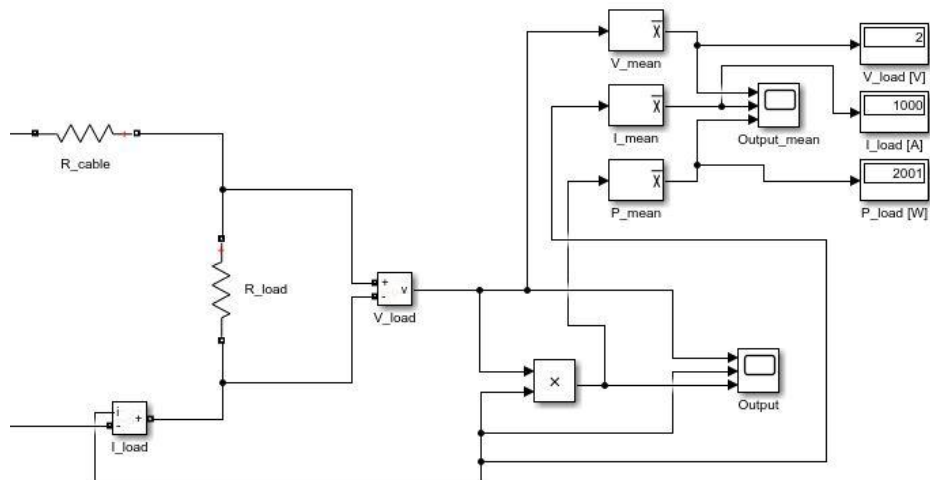

Figure 4.9: Generated output/load values of the directly connected rectifier model, here for output voltage, output current and output power

4 Modelling and Simulation of a DC Power Supply

The voltage was measured across the load resistor by a voltage measurement, while the current was measured in series with the load resistor by a current measurement. By multiplying the voltage and current signals, the output power could also be measured. This was performed using the power law equation given by

$$P = V * I \quad (4.1)$$

where P is power, V is voltage and I is current.

4.3.4 Power Loss and Efficiency of the Rectifier Model

To calculate the power loss and the efficiency of the rectifier model, the power which is conducted in the different components in the circuit is necessary to be measured. Power input to the circuit is the power conducted from the three-phase AC voltage sources, while the output power is referred to as the power conducted at the load. The other components in the circuit which conducts power, like the transformer, diodes, and cable resistor, will be referred to as conducted power which is lost (power loss) from the input to the output of the circuit.

Figure 4.10 a) shows how the power was measured for the input power of the AC voltage sources. The voltage was measured across each of the voltage sources, while the current was measured in series with the voltage sources. Using Equation (4.1), voltage and current were multiplied to get power for each of the voltage sources, and the three power signals were added and sent through a mean block to get the mean total input power of the sources. The total input power, P_{in} , equals 6812 W.

Figure 4.10 b) shows how the power was measured for the transformer regarding the resistors connected to the transformer. The power was measured with the same technique as for the input power, here with voltage measurements across a resistor and current measurements in series with the resistor. The total power for the transformer, $P_{transformer}$, then equals 630.5 W.

4 Modelling and Simulation of a DC Power Supply

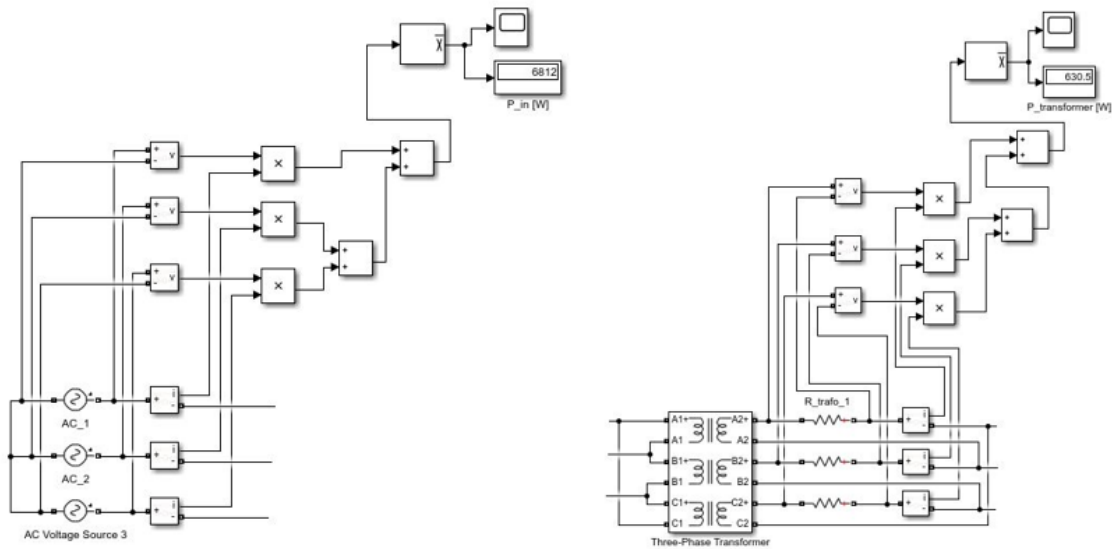

Figure 4.10: a) Shows the power measurement and the generated power for the AC voltage sources

b) Shows the power measurement and the generated power for the transformer

Figure 4.11 a) shows how the power was measured for the diode bridge. It is to be mentioned that the figure only shows three out of six diodes in the circuit, and that the total power of the diodes here includes all the six diodes. The power was measured with the same technique as for the input power, here with voltage measurements across a diode and current measurements in series with a diode. The total power for the diode bridge, P_{diodes} , then equals 3491 W.

Figure 4.11 b) shows how the power was measured for the cable which is placed between the diode bridge and the load. The power was measured with the same technique as for the input power, here with voltage measurement across the cable resistor and current measurement in series with the resistor. The total power for the cable, P_{cable} , then equals 688.5 W.

4 Modelling and Simulation of a DC Power Supply

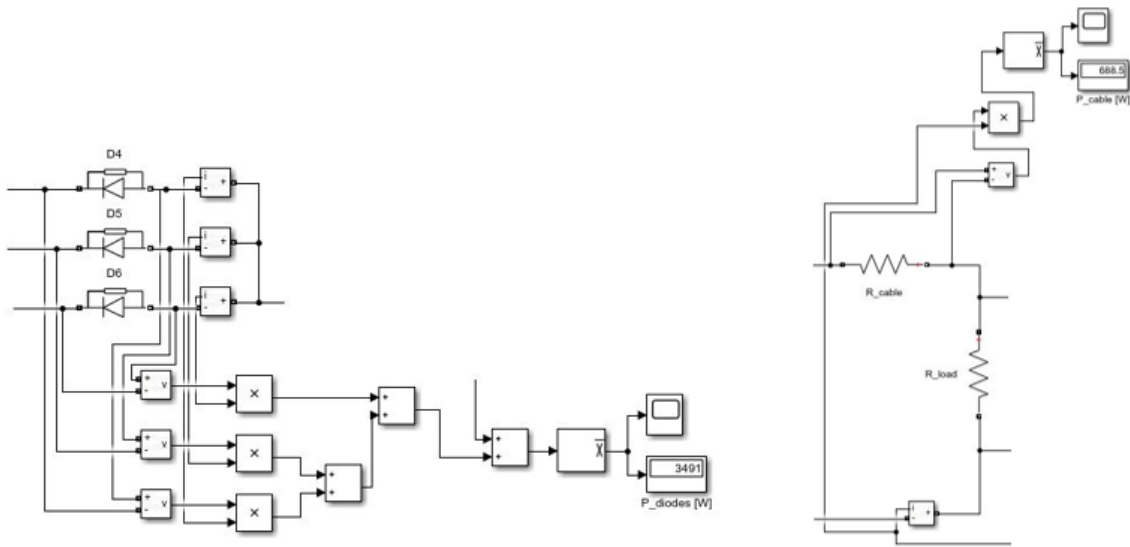

Figure 4.11: a) Shows the power measurement and the generated power for the diode bridge

b) Shows the power measurement and the generated power for the cable

The power loss in the rectifier model is then given by

$$P_{loss} = P_{transformer} + P_{diodes} + P_{cable} \quad (4.2)$$

where P_{loss} is the power loss, $P_{transformer}$ is the power from the transformer, P_{diodes} is the power from the diodes and P_{cable} is the power from the cable.

Using Equation (4.2) the power loss is then equal to 4810 W or approximately 4.8 kW.

At the end it is interesting to look at the efficiency of the rectifier model, which is given by

$$\eta = \frac{P_{load}}{P_{in}} \quad (4.3)$$

where η is the efficiency, P_{load} is the output power and P_{in} is the input power.

Using Equation (4.3), where the output power is equal to 2001 W and the input power is equal to 6812 W, the efficiency of the rectifier model is equal to 29.4 %.

4 Modelling and Simulation of a DC Power Supply

A summary of the simulated and calculated power, loss and efficiency values in this part can be seen in Table 2.

Table 2: Shows the input power, the output/load power, power loss and efficiency of the diode rectifier model

P_{in} [W]	P_{load} [W]	P_{loss} [W]	Efficiency, η [%]
6812	2001	4810	29.4

4.3.5 Variation in AC Supply Voltage to the Power Supply

Variations in the AC supply voltage may affect the DC output of the power supply. It is desired to have a controlled DC output from the power supply such that it would not affect the supplied system if it would be variations in the AC supply voltage.

To observe and understand what will happen to the DC output values at the load if the AC supply voltage increases or decreases according to the nominal input voltage, the voltage of the AC voltage sources will be changed from the nominal voltage which is 230 V. The test will be to increase the AC voltage sources by 10 % to observe how the DC output responds to the change.

With an increase of 10 % of the AC voltage, the new value will be 253 V for each of the voltage sources. By modifying the AC voltage sources in the Simulink model with the new voltage value, the results of the DC outputs both before and after the change can be seen in Table 3.

Table 3: Shows the results in DC outputs of the rectifier model both before and after changing the value of the AC supply voltage

AC voltage source [V]	V_{load} [V]	I_{load} [A]	P_{load} [W]
230	2	1000	2001
253	2.263	1131	2562

With an increase of 10 %, it can be seen that the DC output voltage changed with 0.263 V, the output current changed with 131 A, and the output power changed with 561 W. It will correspond to an increase in percentage of 13.2 %, 13.1 % and 28 % respectively.

4.3.6 Discussion

The diode rectifier circuit itself is a simple model of a power supply mainly consisting of a transformer to transform the voltage to a lower level and a diode bridge which will rectify the AC voltage to a DC voltage. It is easy to adjust the component values such that it will give desired output values for the power supply.

One thing to notify is that the efficiency of the rectifier is quite low, here with an efficiency of 29.4 %. As there may be higher losses in case of a high current, it is related to the low efficiency of the rectifier. Therefore, it will be interesting to model and simulate the same circuit of a rectifier but with a decrease in the current in case of less losses. This may be performed by sectioning the rectifier and connect it in series, which will decrease the current and increase the voltage.

Another thing to notify is the test with the variation in the AC supply voltage and how the DC output values corresponded to the change in input voltage. It showed an increase of 13 % in the voltage output, here with an increase of 10 % in the AC supply voltage. It shows that the DC outputs will be affected if there will be changes in the supply voltage, which is not desired due to that the DC outputs should have a quite constant DC voltage regarding the connection to the supplied system.

4.4 Three-Phase Diode Rectifier Sectioned and Connected in Series

The second power supply model which is modelled and simulated in Simulink is a three-phase diode rectifier which is sectioned and connected in series. It is similar to the Simulink circuit of the first diode rectifier in subchapter 4.3 but with modifications as the load (output resistor/the MES) in principle will be connected in series (only the value of the resistor will be changed in the Simulink model), while the other rectifier was connected directly. This is due to that the first rectifier had a relatively poor efficiency, such that the purpose of the sectioned rectifier in this subchapter is to increase the efficiency of the circuit.

The load/the MES will be sectioned with 10 cells in series, such that the output voltage will increase and the output current will decrease. Based on the desired output values for the first rectifier model in subchapter 4.3, the sectioned rectifier will have desired output values with a voltage of 20 V and a current of 100 A, which gives the output power of the power supply to be 2000 W. The voltage is now ten times higher and the current is ten times lower than the rectifier which was connected directly.

For this power supply model, it is the transformer that will be adjusted, due to its voltage ratio, such that the output voltage will gain its desired value, as well as the current and the power will gain its values.

4.4.1 Model Setup

The model setup for the three-phase rectifier model in Simulink can be seen in Figure 4.12. As mentioned, it has the same setup as for the first rectifier model and consist of a three-phase AC voltage source, a three-phase transformer with connected resistors (which will later represent

4 Modelling and Simulation of a DC Power Supply

the losses in the transformer), a diode bridge used as a rectifier, a resistor as the cable, and a resistor at the end as the load.

The complete model setup with measurements of voltage, current and power in the circuit can be seen in Figure 4.6.

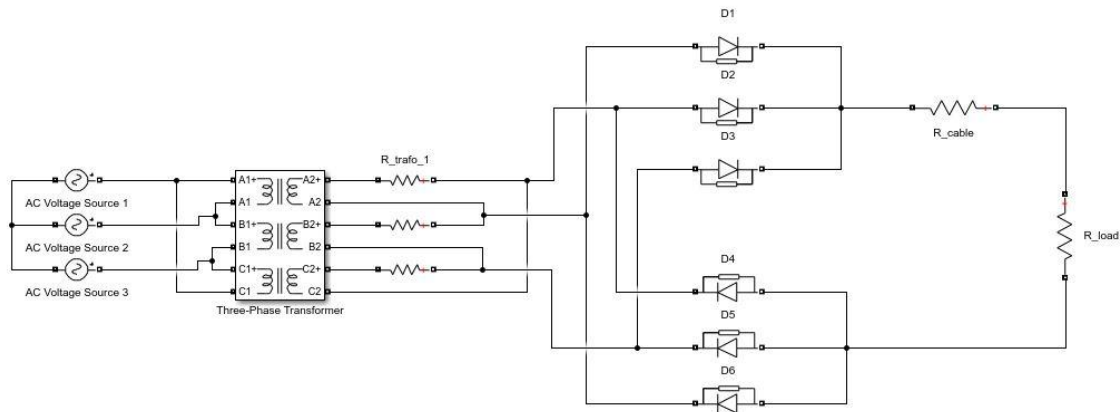

Figure 4.12: Three-phase diode rectifier model in Simulink

4.4.2 Working Principle of the Rectifier Model

The diode rectifier which is sectioned and connected in series in this part has the same working principle as for the rectifier which was connected directly. Therefore, the working principle of the rectifier model can be seen in subchapter 4.3.2.

4.4.3 Generated Output Values from Simulation

The rectifier model has desired output values of 20 V and 100 A. The generated output values from the simulation of the rectifier model in Simulink can be seen in Figure 4.13. The measured mean values have an output voltage, V_{load} , of 20 V, an output current, I_{load} , of 100 A, and an output power, P_{load} , of 2004 W.

It is to mentioned that the output values were measured in the same way as described for the output values in subchapter 4.3.3, and the power was measured by using the principle of Equation (4.1).

4 Modelling and Simulation of a DC Power Supply

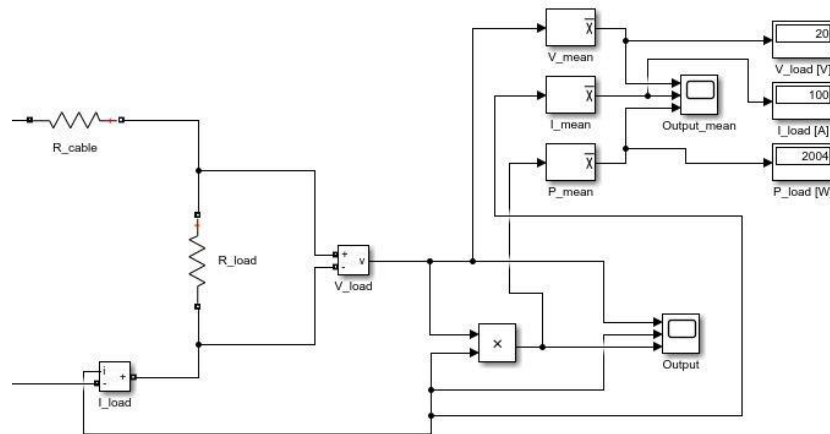

Figure 4.13: Generated output/load values of the sectioned rectifier model, here for output voltage, output current and output power

4.4.4 Power Loss and Efficiency of the Rectifier

To calculate the power loss and the efficiency of the rectifier model, the power which is conducted in the different components in the circuit is necessary to be measured. As for the first rectifier model, the input power is referred to as the power generated in the AC voltage sources, the output power is referred to as the power generated in the load, and the power loss is power which is generated and lost through the transformer, diodes and cable.

It is to be mentioned that the power in the different components was measured in the same way as described for the components in subchapter 4.3.4, and by using the principle of Equation (4.1).

Figure 4.14 a) shows how the power was measured for the input power of the AC voltage sources. The total input power, P_{in} , then equals 2324 W.

Figure 4.14 b) shows how the power was measured for the transformer regarding the resistors connected to the transformer. The total power of the transformer, $P_{transformer}$, then equals 132.7 W.

4 Modelling and Simulation of a DC Power Supply

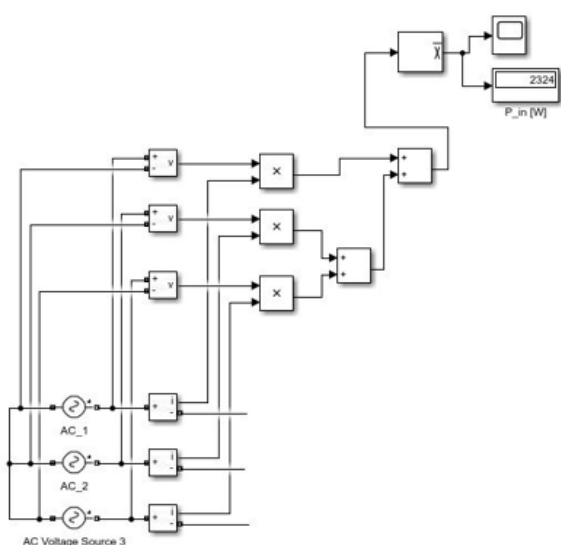
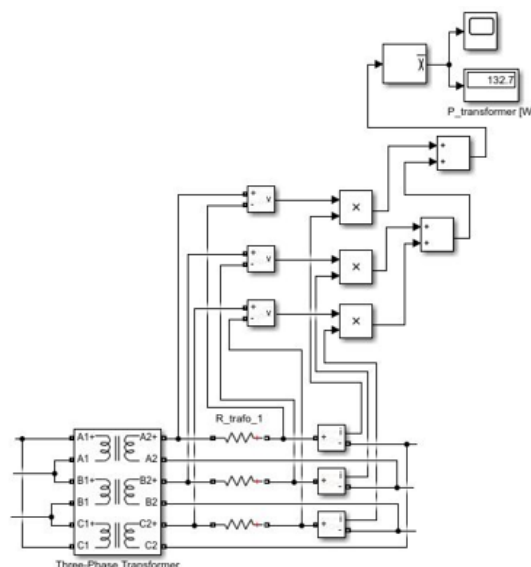

Figure 4.14: a) Shows the power measurement and the generated power for the AC voltage sources



b) Shows the power measurement and the generated power for the transformer

Figure 4.15 a) shows how the power was measured for the diode bridge. The total power for all the six diodes, P_{diodes} , then equals 179.9 W.

Figure 4.15 b) shows how the power was measured for the cable which is placed between the diode bridge and the load. The total power for the cable, P_{cable} , then equals approximately 6.9 W.

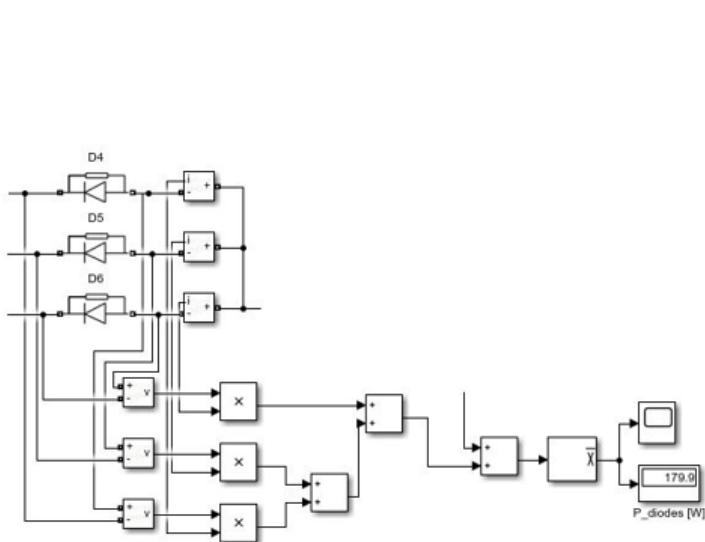
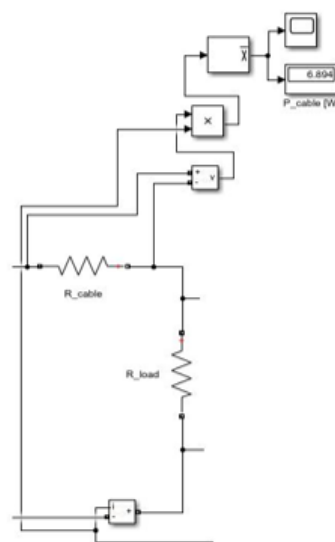

Figure 4.15 a) Shows the power measurement and the generated power for the diode bridge



b) Shows the power measurement and the generated power for the cable

4 Modelling and Simulation of a DC Power Supply

The power loss in the rectifier model is then calculated by using Equation (4.2) which includes the power that is lost through the transformer, diodes and cable. By using Equation (4.2), the power loss is then equal to 319.5 W.

When it comes to the efficiency of the rectifier model, Equation (4.3) will be used to calculate the efficiency. With an input power of 2324 W and an output/load power of 2004 W, the efficiency of the rectifier model is equal to 86.2 %.

A summary of the simulated and calculated power, loss and efficiency values in this part can be seen in Table 4.

Table 4: Shows the input power, the output/load power, power loss and efficiency of the diode rectifier model

P_{in} [W]	P_{load} [W]	P_{loss} [W]	Efficiency, η [%]
2324	2004	319.5	86.2

4.4.5 Variation in AC Supply Voltage to the Power Supply

Variations in the AC supply voltage may affect the DC output of the power supply. Similarly, as for the first rectifier model, the purpose is to observe what will happen to the DC output values at the load if the AC supply voltage increases or decreases according to the nominal input voltage of 230 V. The AC voltage sources will be increased by 10 % to observe the response of the DC output values.

With an increase of 10 % of the AC voltage, each of the AC voltage sources will have a new value of 253 V. By modifying the AC voltage sources in the Simulink model with the new voltage value, the results of the DC outputs both before and after the change can be seen in Table 5.

Table 5: Shows the results in DC outputs of the rectifier model both before and after changing the value of the AC supply voltage

AC voltage source [V]	V_{load} [V]	I_{load} [A]	P_{load} [W]
230	20	100	2004
253	22.15	110.7	2457

With an increase of 10 %, it can be seen that the DC output voltage changed with 2.15 V, the output current changed with 10.7 A, and the output power changed with 453 W. It will correspond to an increase in percentage of 10.8 %, 10.7 % and 22.6 % respectively.

4.4.6 Discussion

Similarly to the first rectifier model in subchapter 4.3, the rectifier model where the load is sectioned and connected in series in this part is a simple model of a power supply, and mainly consisting of a transformer to regulate the voltage level and a diode bridge to rectify the AC voltage to a DC voltage. Likewise, as for the first rectifier model, it is easy to adjust the component values in the circuit to obtain desired output values for the power supply.

One thing to notify is that the efficiency increased to 86.2 % by sectioning and connecting the load of the diode rectifier model in series. The current was decreased by ten times the current in the first rectifier, such that it may have affected to less power loss in the circuit, which further affects the efficiency to increase. The purpose of this model is reached with its significantly higher efficiency from 29.4 % to 86.2 % regarding the first rectifier model connected directly and to the second rectifier model where the load was sectioned and connected in series.

Another thing to notify is the test with variations in the AC supply voltage in case of observing how the DC output values would respond to the change in input voltage. It showed an increase of 10.8 % in the voltage output, here with an increase of 10 % in the AC supply voltage. It shows that, likewise as for the first rectifier, that the DC outputs will be affected if there will be changes in the supply voltage, which is not desired as the purpose is to have a constant DC output of the power supply regarding the connection to the supplied system.

As the rectifier circuits have a problem with the DC output values due to possible variations in the AC supply voltage, it is interesting to develop a power supply which can regulate the voltage in the DC output to have a constant, desired value even though it may be variations in the AC supply voltage. This may be obtained by developing circuits with power electronic components which can be regulated.

Another thing to notify is that the research group had an additional requirement, seen in the system description in subchapter 2.2, that the power supply may need to supply two different voltage levels during the operating process. This may be obtained by introducing tapping on the transformer to modify the transformer winding ratio, whereas this may complicate the transformer design and will only provide discrete steps in output voltage level. This is another argument for developing a regulated power supply with power electronic components.

4.5 Half-Bridge DC-DC Converter - Sectioned and Connected in Series

The third power supply model which is modelled and simulated in Simulink is a half-bridge DC-DC converter which is sectioned and connected in series, and which has a rectified AC supply voltage as its DC input. It will be modelled without any kind of electrical isolation and is therefore a simpler version of a half-bridge converter. This will be commented in the discussion at the end of the subchapter.

Based on the significantly increase in efficiency with the change from a directly connected power supply and further to a sectioned and series connected power supply in subchapter 4.3 and 4.4, the next power supply models will continue to be sectioned and connected in series.

Therefore, the half-bridge converter model will be sectioned with 10 in series. The desired output values of the converter will have a voltage of 20 V and a current of 100 A, which gives the output power of the power supply to be 2000 W.

4.5.1 Model Setup

The model setup of the half-bridge DC-DC converter in Simulink can be seen in Figure 4.16. It consists of a three-phase AC voltage source, a diode bridge used as a rectifier, a sawtooth generator which generates a PWM signal, a capacitor as the DC input, two MOSFET switches, an inductor and a capacitor as a filter, and at the end a resistor as the load.

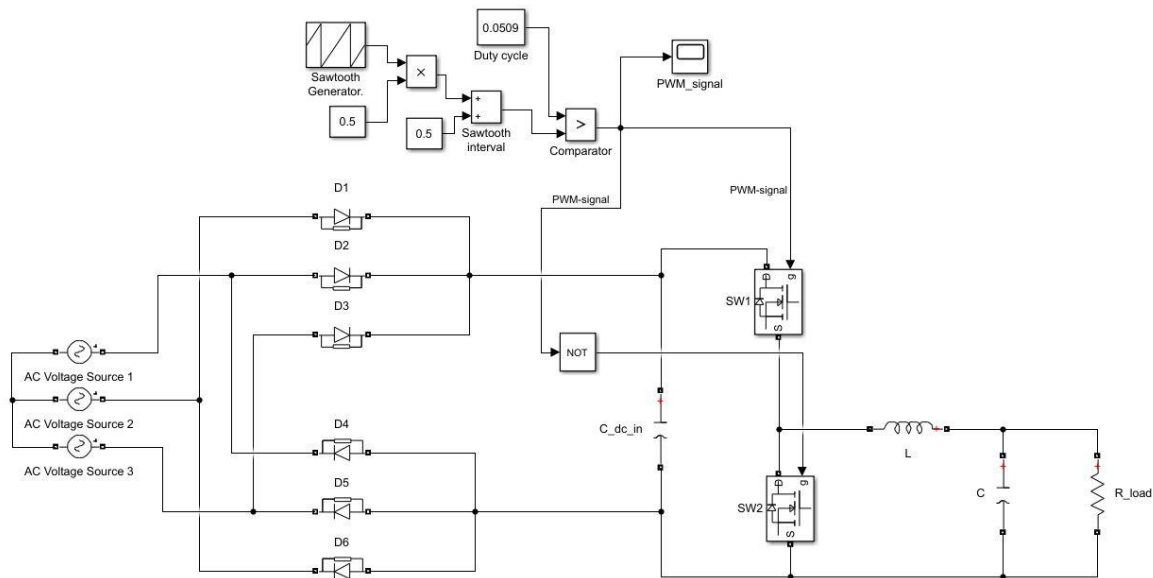

Figure 4.16: Half-bridge DC-DC converter model in Simulink with a rectified AC supply voltage as the DC input to the circuit

The complete model setup with measurements of voltage, current and power in the circuit can be seen in Figure 4.17.

4 Modelling and Simulation of a DC Power Supply

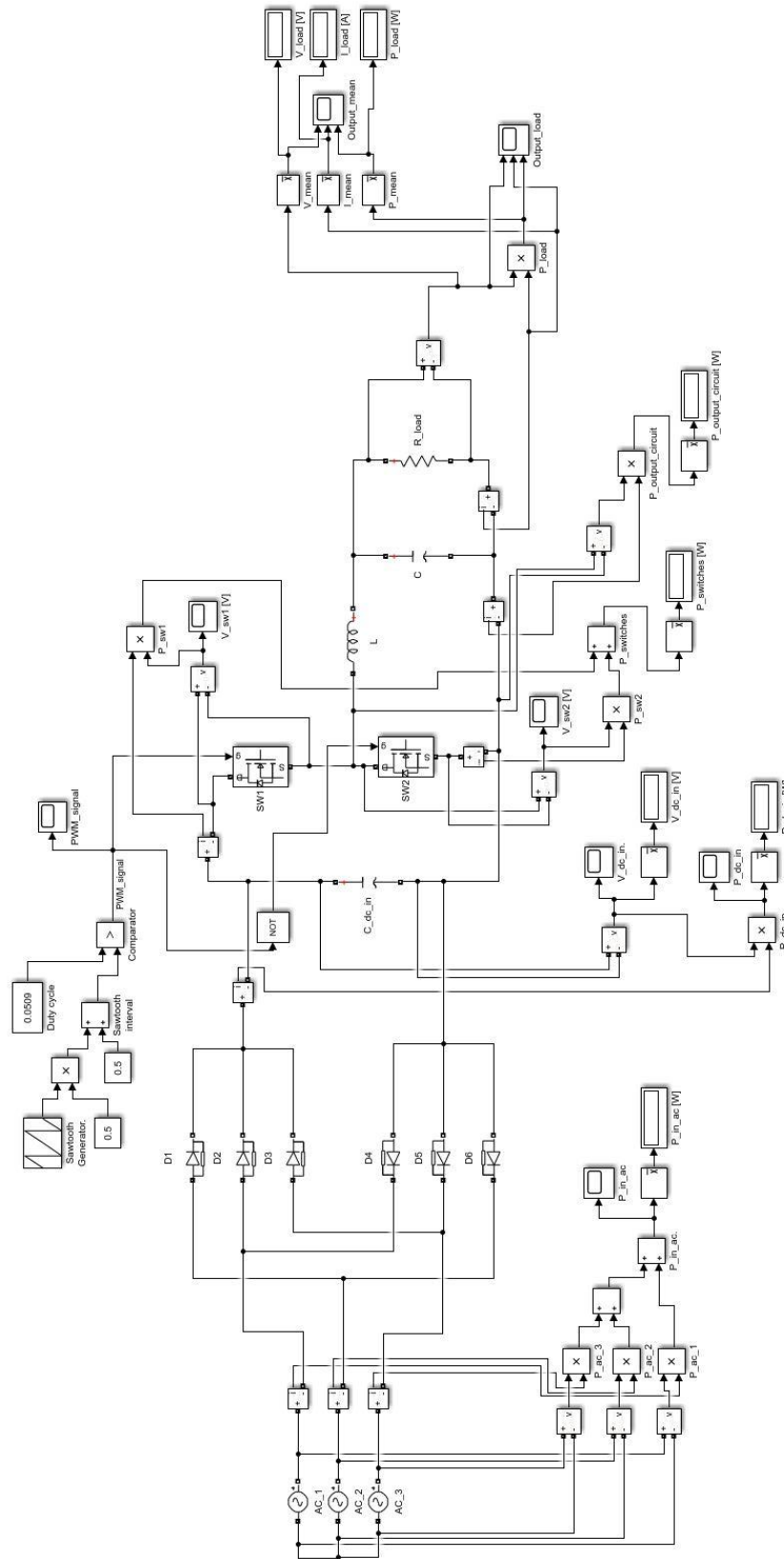

Figure 4.17: Complete model setup of the half-bridge converter in Simulink including measurements of the components in the circuit

4 Modelling and Simulation of a DC Power Supply

4.5.2 Working Principle of the Half-Bridge Converter Model

The aim of this half-bridge converter model is to rectify the incoming AC supply voltage such that it will generate a DC voltage input to the DC-DC converter, where the DC-DC converter further converts the DC voltage input to a desired DC output voltage level at the load. The output of the power supply will be connected to the biochemical system.

The incoming AC supply voltage, which can be seen in Figure 4.18, is a three-phase voltage supply where each of the voltage sources have a phase shift of 120 degrees. AC voltage source 1 is at 0 degrees, the second voltage source has a phase shift of 120 degrees and the third voltage source has a phase shift of 240 degrees. Each of the voltage sources has a phase voltage of 230 V, which is due to that the line voltage is set to be 400 V and the voltage sources is connected in a star configuration.

Figure 4.18 also consist of a diode bridge which is a three-phase rectifier consisting of six diodes. The diode bridge will convert the incoming AC voltage to a DC voltage, where the DC voltage is the voltage input of the DC-DC converter.

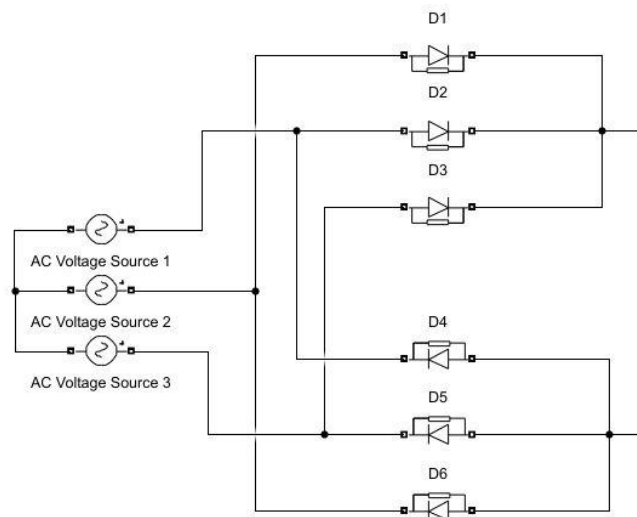

Figure 4.18: Three-phase AC voltage supply and the diode bridge/rectifier which is connected to the DC-DC converter

The incoming DC voltage to the DC-DC converter is transferred across the capacitor C_{dc-in} as seen in Figure 4.19, which is further connected to two MOSFET switches. As the aim of the half-bridge converter is to obtain desired output values at the load, the switches will be controlled by Pulse-width Modulation (PWM). Pulse Width Modulation is used to control the output voltage to a desired value by changing the duration time of the switches in the circuit, and by switching at a constant frequency.

To generate a PWM signal to the switches in the circuit, a sawtooth waveform is compared to a control voltage signal as seen in the upper left of Figure 4.19. The sawtooth waveform is generated by a sawtooth generator which has an interval from -1 to 1. However, with the modifications made in the circuit, the interval of the sawtooth generator will be from 0 to 1.

4 Modelling and Simulation of a DC Power Supply

The control voltage signal will be referred to as the duty cycle (or duty ratio) of the switches which has an interval from 0 to 1 (which refers to 0 to 100 % duty cycle).

The generated PWM signal will be sent to each switch gate from the comparator depending on whether the PWM signal is on or off. When the time period of the PWM signal is ON, which is referred to the duty cycle, the signal will be sent to switch 1 (SW1) and establish a voltage in the midpoint between the switches. When the time period of the PWM signal is OFF, the signal will be sent to switch 2 (SW2) via a “NOT” block. It will establish a negative voltage across switch 2, and the voltage in the midpoint between the switches will be zero.

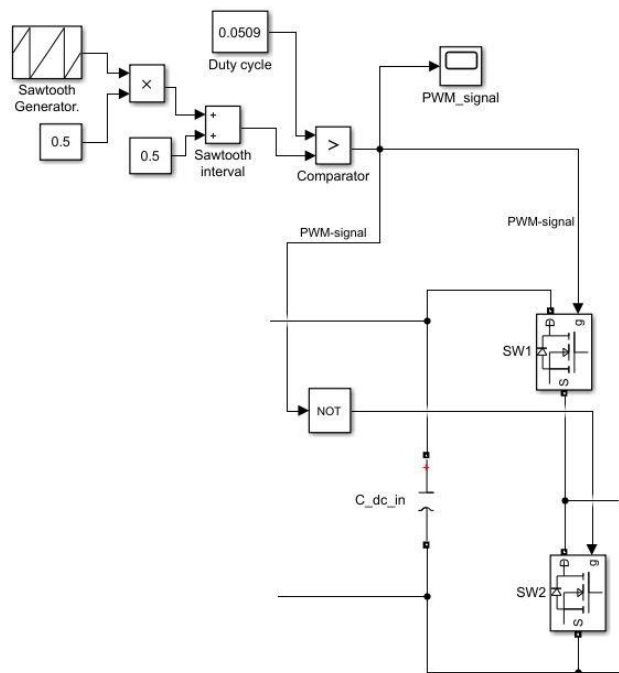

Figure 4.19: Shows how the PWM signal is generated and sent to the MOSFET switches

The circuit that is connected to the right side of the switches is the output circuit of the DC-DC converter, which can be seen in Figure 4.20. The DC voltage, which may have some ripple voltage left from the rectification, will be filtered by the inductor, L, and the capacitor, C, which works as a filter, such that the DC output voltage at the load, R_{load} , will become a smooth DC voltage.

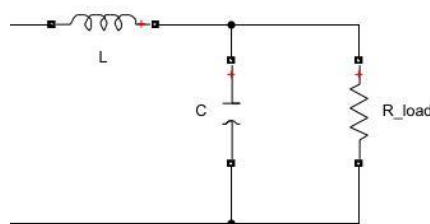

Figure 4.20: Output circuit of the DC-DC converter

4 Modelling and Simulation of a DC Power Supply

4.5.3 Generated Output Values from Simulation

The half-bridge converter model has desired output values of 20 V and 100 A. To obtain these values, the duty ratio, D , were adjusted to have a value of 0.0509, which contributes to that the PWM signal has a duty cycle (on time) of 5.1 % and that switch 1 only conduct in 5.1 % of every time period. The PWM signal with its respective duty cycle can be seen in Figure 4.21.

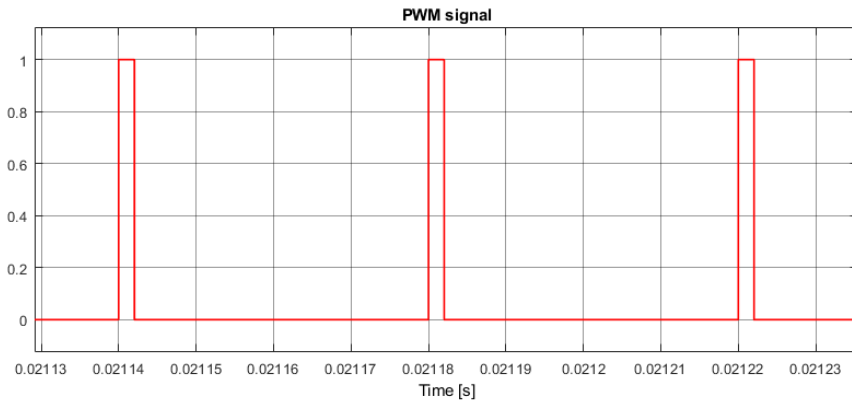

Figure 4.21: Generated PWM signal with a duty cycle of 5.1 %

The simulation time were set to be 0.1 second such that the output values would reach its steady state and get stabilized before the measuring. The generated output values from the simulation of the half-bridge model in Simulink can be seen in Figure 4.22, where the mean values of the output values were measured with an output voltage, V_{load} , of 20.04 V, an output current, I_{load} , of 100.2 A, and an output power, P_{load} , of 2006 W.

It is to be mentioned that the output values were measured in the same way as described for the output values in subchapter 4.3.3, and the power was measured by using the principle of Equation (4.1).

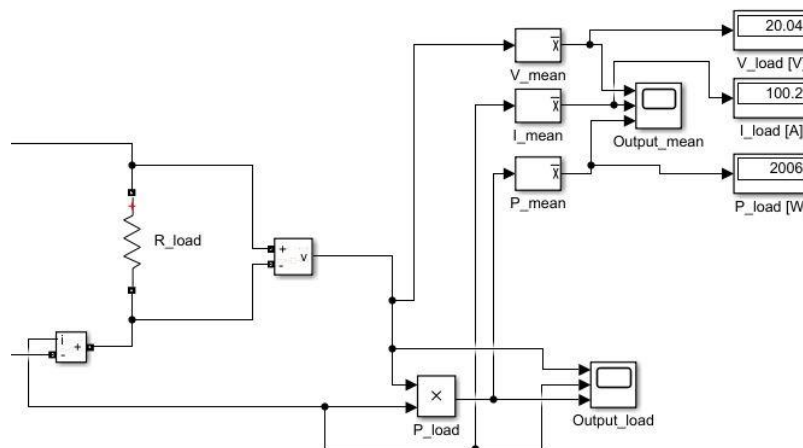

Figure 4.22: Generated output/load values of the half-bridge converter, here for output voltage, output current and output power

4 Modelling and Simulation of a DC Power Supply

4.5.4 Power Loss and Efficiency of the Half-Bridge Converter

To calculate the power loss and the efficiency of the half-bridge converter, the power which is conducted in the different components in the circuit will be measured. The input power is referred to as the power generated in the AC voltage sources, the output power is referred to as the power generated in the load, and the power loss is power which is generated and lost through the diode bridge, the switches and the output circuit.

It is to be mentioned that the power in the different components was measured in the same way as described for the power in subchapter 4.3.4, and by using the principle of Equation (4.1).

Figure 4.23 a) shows how the power was measured for the input power of the AC voltage sources. The total input power, P_{in-ac} , then equals 2032 W.

Further, Figure 4.23 b) shows how the remaining power was measured in the DC input to the DC-DC converter after the diode bridge. The power into the DC input, P_{dc-in} , then equals to 2023 W. However, the power which was generated in the diode bridge is then equal to the subtraction between the AC input power and the DC input power, and $P_{diode-bridge}$ then equals 9 W.

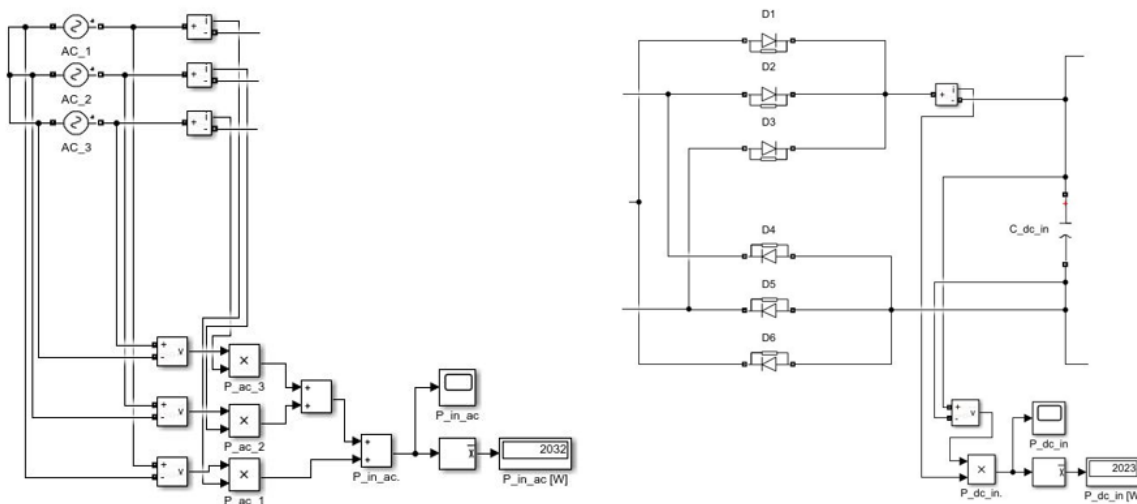

Figure 4.23: a) Shows the power measurement and the generated power for the AC sources

b) Shows the power measurement and the remaining power in the DC input after the diode bridge

Figure 4.24 a) shows how the power was measured for the two MOSFET switches in the circuit. The total power for the switches, $P_{switches}$, then equals 15.34 W.

Further, Figure 4.24 b) shows how the remaining power was measured before the output circuit. The power into the output circuit, $P_{output-circuit}$, then equals 2007.66 W. As the output/load power equals to 2006 W, it means that 1.66 W is lost between the switches and the load.

4 Modelling and Simulation of a DC Power Supply

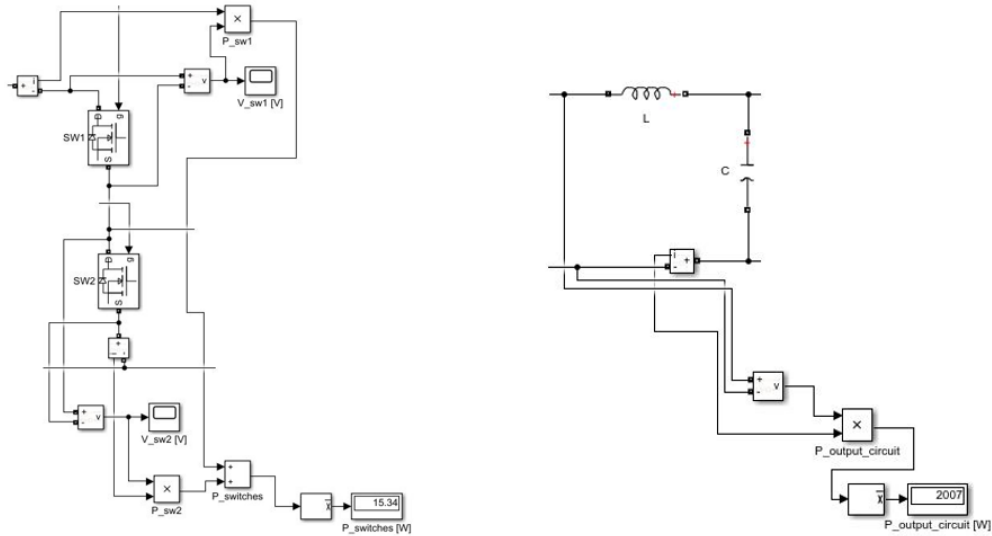

Figure 4.24: a) Shows the power measurement and the generated power for the switches

b) Shows the power measurement and the remaining power before the output circuit

The power loss in the half-bridge converter is then given by

$$P_{loss} = P_{diode_bridge} + P_{switches} + P_{output_circuit} \quad (4.4)$$

where P_{loss} is the power loss, P_{diode_bridge} is the power lost in the diode bridge, $P_{switches}$ is the power lost in the switches, and $P_{output_circuit}$ is the power lost in the output circuit.

By using Equation (4.4), the power loss then equals 26 W.

When it comes to the efficiency of the half-bridge converter model, the calculation will be based on Equation (4.3). With an input power (from the AC sources) of 2032 W and an output/load power of 2006 W, the efficiency of the half-bridge model is then equal to 98.7 %.

A summary of the simulated and calculated power, loss and efficiency values in this part can be seen in Table 6.

Table 6: Shows the input power (from the AC sources), the output/load power, power loss and efficiency of the half-bridge converter model

P_{in} [W]	P_{load} [W]	P_{loss} [W]	Efficiency, η [%]
2032	2006	26	98.7

4 Modelling and Simulation of a DC Power Supply

4.5.5 Variation in AC Supply Voltage to the Power Supply

Variations in the AC supply voltage may affect the DC output of the power supply. Similarly, as for the two rectifier models, the purpose is to observe what will happen to the DC output values at the load if the AC supply voltage increases or decreases according to the nominal input voltage of 230 V. The AC voltage sources will be increased by 10 %, which gives the new value for each of the AC sources to be 253 V.

By modifying the AC voltage sources in the Simulink model with the new voltage value, the results of the DC outputs both before and after the change can be seen in Table 7. It is to be noted that the duty cycle is not changed and is still 5.1 %.

Table 7: Shows the results in DC outputs of the half-bridge converter model both before and after changing the value of the AC supply voltage

AC voltage source [V]	V_{load} [V]	I_{load} [A]	P_{load} [W]
230	20.04	100.2	2006
253	22.05	110.2	2430

With an increase of 10 %, it can be seen that the DC output voltage changed with 2.01 V, the output current changed with 10 A, and the output power changed with 424 W. It will correspond to an increase in percentage of 10 %, 10 % and 21.1 % respectively.

The advantage of the half-bridge converter is that the duty cycle can be increased or decreased such that the output voltage corresponds to the change of duty cycle. By reducing and optimize the duty cycle, the output values can gain the desired output values, nevertheless the AC supply voltage will vary.

4.5.6 Discussion

Compared to the two diode rectifier models, the half-bridge converter model is a more complicated circuit since it consists of power electronic components like switches. The advantage of this setup is that the duration time of the switches can be changed by changing the duty cycle of the PWM signal, such that the switches can be controlled and that the change of the duty cycle will correspond to a change in the output values, whether the purpose is to increase or decrease the output values.

One thing to notify is that the efficiency of the half-bridge converter model, which was sectioned and connected in series, was very good and had an efficiency of 98.7 %. With this efficiency, the power loss through the circuit was only 26 W. It means that the converter is quite effective and a good choice if one only takes the efficiency and the power losses into account.

However, there is several things to discuss regarding the circuit, and the first problem may be regarding the switch utilization of the switches. This is due to that the duty cycle is equal to 5.1

4 Modelling and Simulation of a DC Power Supply

% and that switch 1 only conducts 5.1 % of a time period, which means that all the energy will be sent through switch 1 over a short time period. Besides that, it means that the switch needs to bear both the input voltage and the output current over a short time. It will be a need for a discussion whether the switch will manage to operate under these conditions or if it will affect the lifetime of the switch. According to Figure 3.5, it shows that for a buck converter (step down), which is more likely to be compared to the half-bridge circuit, that the duty cycle should be longer to get the most efficient switch utilization of the switches. It means that the switch utilization for the switches in the half-bridge converter is poor.

Another problem is that the half-bridge converter do not have any electrical isolation in the circuit, which means that the output circuit is not separated from the input circuit/mains, and that variations or faults in the supply voltage may affect or in worst case damage the components in the output circuit. Also, safety for personnel is a factor that counts when it comes to electrical isolation of the circuit.

Likewise, as for the two rectifier models, a variation in the AC supply voltage will affect the DC output values. When the AC voltage sources were increased with 10 %, also the output voltage of the converter changed with 10 %. It is not desired that the output values should change if the supply voltage change. An advantage of the half-bridge converter is that the duty cycle can be adjusted to compensate for the input variations, and this may be controlled by adding a PID controller such that it will control the duty cycle to give the correct output values independent of possible variations in the mains/supply voltage.

4.6 Half-Bridge DC-DC Converter with Electrical Isolation - Sectioned and Connected in Series

The fourth power supply model which is modelled and simulated in Simulink is based on the half-bridge DC-DC converter in subchapter 4.5 which is sectioned and connected in series, and which has a rectified AC supply voltage as its DC input. However, the converter model will now be improved with electrical isolation in the circuit by adding a transformer, which will electrically separate the input circuit/mains from the output circuit. Other improvements of the circuit will be performed as well as the electrical isolation.

The half-bridge converter model will be sectioned with 10 in series. The desired output values of the converter will have a voltage of 20 V and a current of 100 A, which gives the output power of the power supply to be 2000 W.

4.6.1 Model Setup

The model setup for the half-bridge DC-DC converter with electrical isolation in Simulink can be seen in Figure 4.25. It consists of a three-phase AC voltage source, a diode bridge used as a rectifier, a sawtooth generator which generates a PWM signal, a Flip-Flop block circuit which controls the switch signals, two capacitors as the DC input, two MOSFET switches, a linear transformer, two diodes in the outer circuit, an inductor and capacitor as a filter, and at the end a resistor as the load.

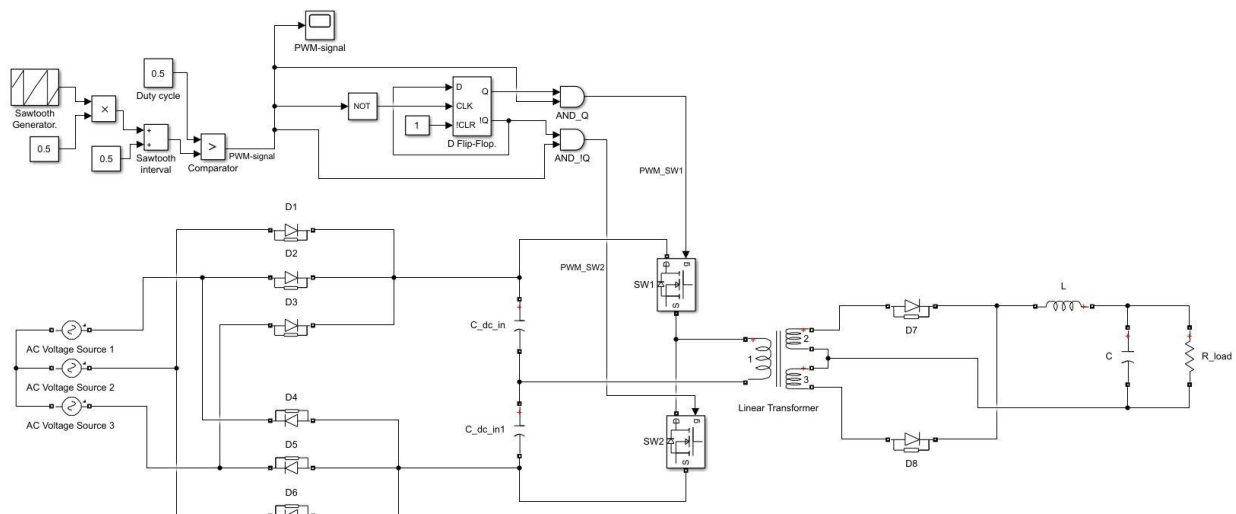

Figure 4.25: Half-bridge DC-DC converter model with electrical isolation in Simulink, here with a rectified AC supply voltage as the DC input to the circuit

The complete model setup with measurements of voltage, current and power of the components in the circuit can be seen in Figure 4.26.

4 Modelling and Simulation of a DC Power Supply

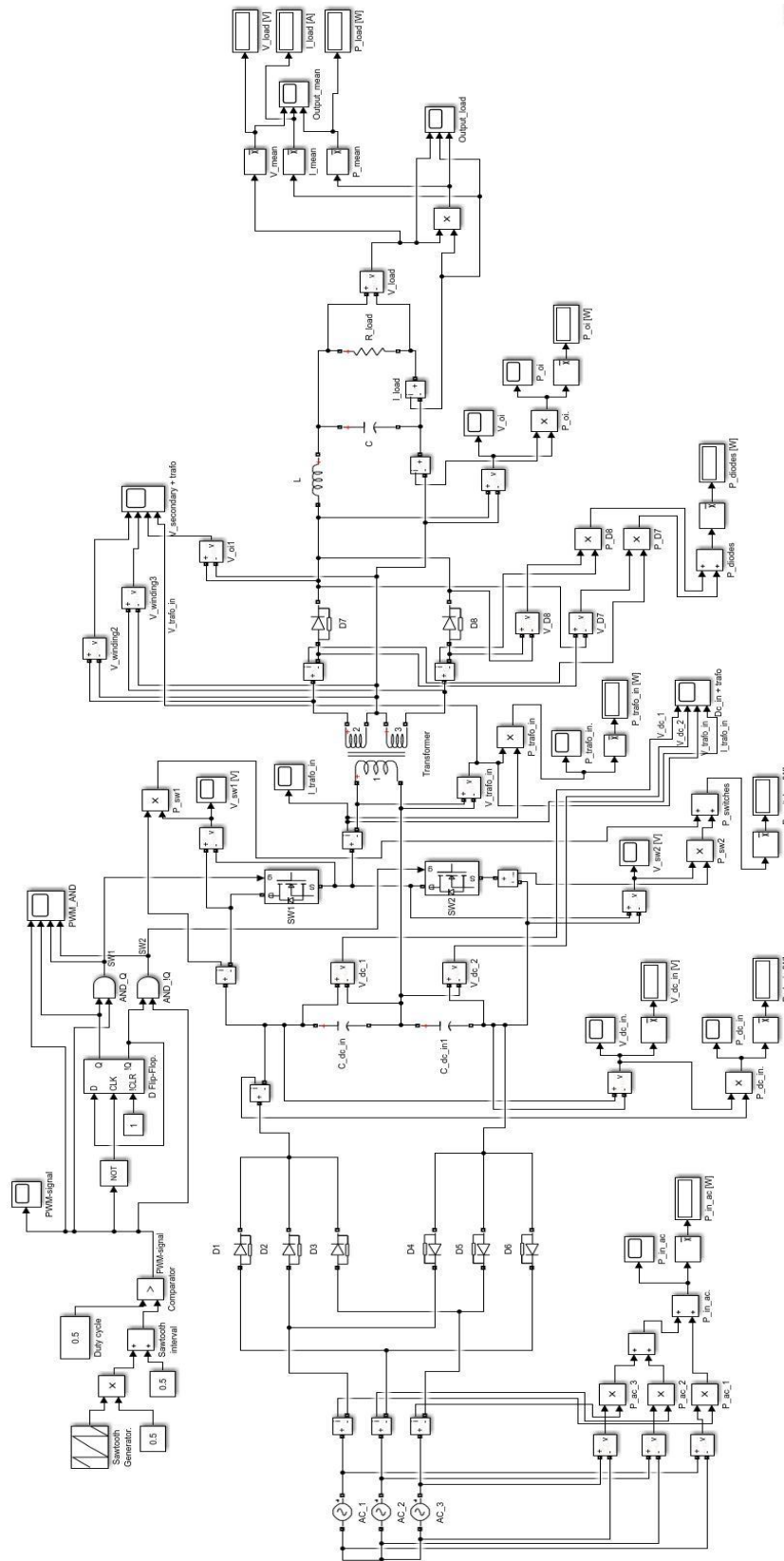

Figure 4.26: Complete model setup of the half-bridge converter with electrical isolation in Simulink including measurements of the components in the circuit

4.6.2 Working Principle of the Half-Bridge Converter Model

Similarly to the half-bridge model in subchapter 4.5.2, the aim of this half-bridge converter model with electrical isolation is to rectify the incoming AC supply voltage such that it will generate a DC voltage input to the DC-DC converter, where the DC-DC converter further converts the DC voltage input to a desired DC output voltage level at the load. The output of the power supply will be connected to the biochemical system.

The incoming AC supply voltage to the converter, as well as the diode bridge, can be seen in Figure 4.27. It has the same working principle and setup similarly to those in subchapter 4.5.2, where the diode bridge will rectify the incoming AC voltage to a DC voltage which is the input to the DC-DC converter.

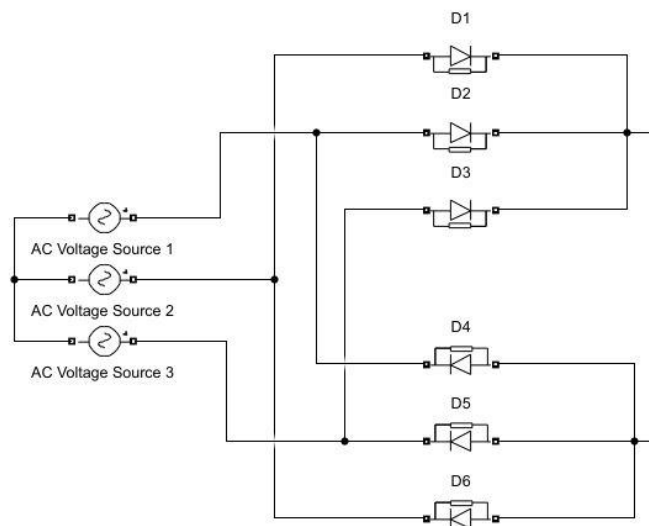

Figure 4.27: Three-phase AC voltage supply and the diode bridge/rectifier which is connected to the DC-DC converter

The part of the converter circuit which controls whether switch 1 or switch 2 will conduct or not can be seen in Figure 4.28 a). According to the description of how the PWM signal will be constructed, as seen in the left part of the figure, it will have the same working principle and sawtooth interval as the constructed PWM signal in the first half-bridge converter seen in subchapter 4.5.2.

However, compared to the first half-bridge converter model, the right part of Figure 4.28 a) is now an improved part from the other half-bridge model as this part now will control whether switch 1 and switch 2 will be on or off. This will be performed by a block called “D Flip-Flop” in Simulink which will control whether a signal will be sent through Q or !Q and out of the block. Through every time period when the PWM signal is OFF the signal will be led to the clock part (clk) of the block, and it will flip between Q and !Q every time period when the PWM signal is OFF. Both the switches are off under this period of flipping. Every time period

4 Modelling and Simulation of a DC Power Supply

when the PWM signal is ON with its respective duty cycle, the flip-flop block will send a signal either through Q or !Q and further to one of the respective AND ports. Switch 1 and switch 2 will have its respective ON time when the PWM signal is ON, but the switches will take turns to conduct every second ON time period.

The results from several generated PWM signals can be seen in Figure 4.28 b), which shows the regular PWM signal, the Q signal which is sent from the Flip-Flop block, the PWM signal which is sent to switch 1, and the PWM signal which is sent to switch 2. It shows, as described above, that the switches take turns to be on every second time period when the PWM signal is on, and that the Q signals flips between the switches.

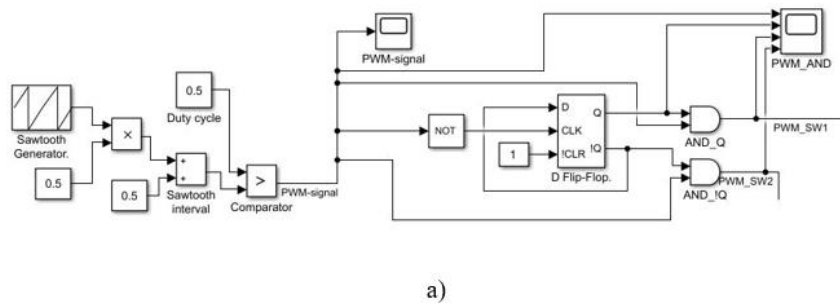

a)

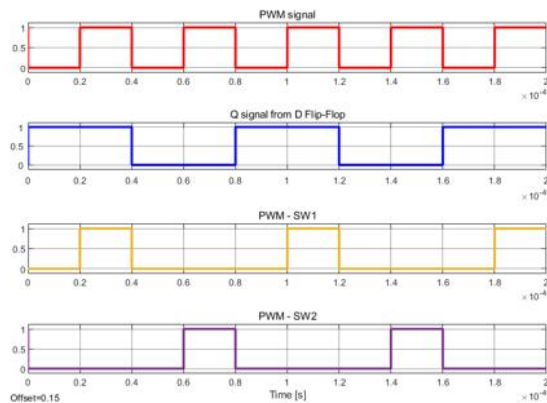

b)

Figure 4.28: a) Shows how the PWM signal is generated and how/when the PWM signal will be sent to the respective switches
 b) Generated PWM signal (red line), Q signal from the Flip-Flop block (blue line), PWM signal sent to switch 1 (yellow line), and PWM signal sent to switch 2 (purple line)

Further, Figure 4.29 shows the part of the circuit where the voltage is transformed to a lower voltage level through a transformer. The transformer is also the part of the circuit which will isolate the input- and output circuit electrically from each other, and is a three-winding linear transformer. The transformation itself depends on whether switch 1 or switch 2 are on. It is to be noted that the voltage on the lower side of the primary transformer winding will have the same value throughout the simulation because it is connected to the midpoint between the two capacitors that makes the DC input.

4 Modelling and Simulation of a DC Power Supply

If switch 1 is on it will give a positive voltage on the upper side of the primary transformer winding. When the transformation takes place, the upper secondary winding will have a positive voltage while the lower secondary winding will have a negative voltage. It means that the upper diode connected to the upper secondary winding will conduct because of a positive voltage, while the lower diode will close because of a negative voltage from the lower secondary winding.

If switch 2 is on it will give a negative voltage on the upper side of the primary transformer winding. The secondary windings will change to the opposite sign of the voltage compared to when switch 1 is on. Therefore, the upper secondary winding will have a negative voltage where the upper diode will close and will not conduct. The lower secondary winding will have a positive voltage which means that the lower diode will conduct.

As there is a risk for the transformer to saturate, switch 1 and switch 2 will conduct every second time such that it will not magnetize the transformer windings significantly.

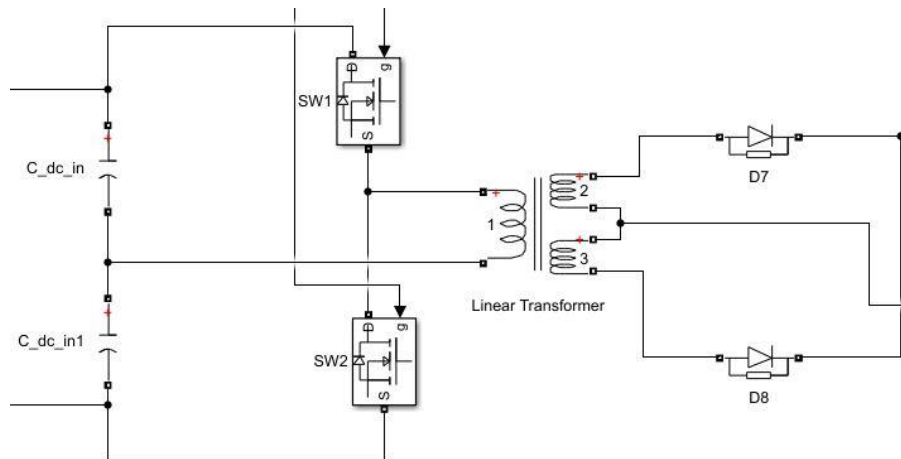

Figure 4.29: A part of the half-bridge circuit with the DC input, the two MOSFET switches, the linear transformer, and the two diodes connected to the transformer and the output circuit

After the voltage transformation, the DC voltage will be filtered before it reaches the load with the same working principle as for the first half-bridge converter model seen in subchapter 4.5.2, such that the DC voltage will become a smooth DC voltage at the load. The output circuit can be seen in Figure 4.30.

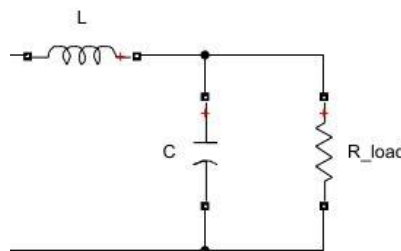

Figure 4.30: Output circuit of the DC-DC converter

4 Modelling and Simulation of a DC Power Supply

4.6.3 Generated Output Values from Simulation

The half-bridge converter model with electrical isolation has desired output values of 20 V and 100 A. To obtain these values, the duty ratio, D , were adjusted to have a value of 0.5, which contributes to that the PWM signal has a duty cycle of 50 %. It means that each of switch 1 and switch 2 conduct in 50 % of the time period when the respective switch is on. The PWM signal with its respective duty cycle can be seen in Figure 4.31.

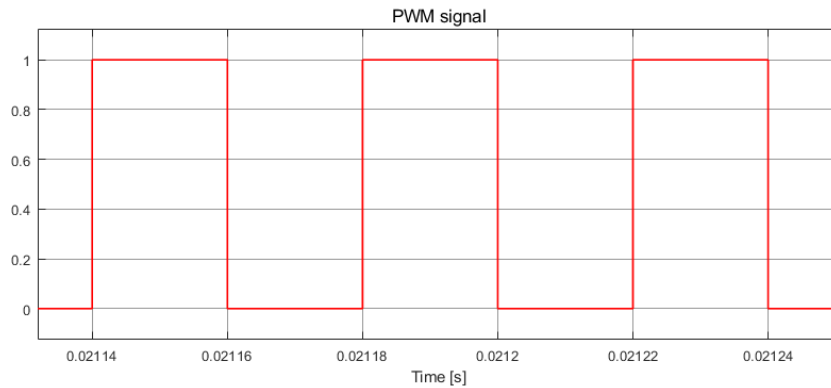

Figure 4.31: Generated PWM signal with a duty cycle of 50 %

The simulation time were set to be 0.15 seconds such that the output values would reach its steady state and get stabilized before the measuring. The generated output values from the simulation of the half-bridge model in Simulink can be seen in Figure 4.32, where the mean values of the output values were measured with an output voltage, V_{load} , of 20.61 V, an output current, I_{load} , of 103.1 A, and an output power, P_{load} , of 2125 W.

It is to be mentioned that the output values were measured in the same way as described for the output values in subchapter 4.3.3, and the power was measured by using the principle of Equation (4.1).

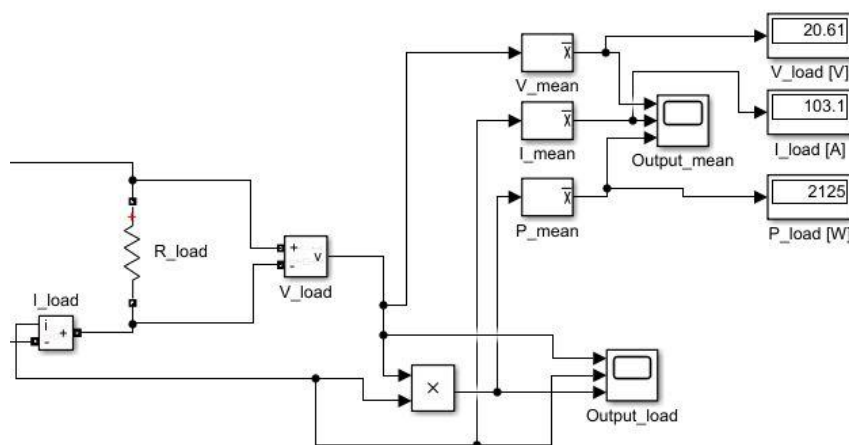

Figure 4.32: Generated output/load values of the half-bridge converter with electrical isolation, here for output voltage, output current and output power

4.6.4 Power Loss and Efficiency of the Half-Bridge Converter

To calculate the power loss and the efficiency of the half-bridge converter with electrical isolation, the power which is conducted in the different components in the circuit will be measured. The input power is referred to as the power generated in the AC voltage sources, the output power is referred to as the power generated in the load, and the power loss is power which is generated and lost through the diode bridge, the switches, the transformer, the two diodes after the transformer, and the output circuit.

It is to be mentioned that the power in the different components was measured in the same way as described for the power in subchapter 4.3.4, and by using the principle of Equation (4.1).

Figure 4.33 a) shows how the power was measured for the input power of the AC voltage sources. The total input power, P_{in-ac} , then equals 2311 W.

Further, Figure 4.33 b) shows how the remaining power was measured in the DC input to the DC-DC converter after the diode bridge. The power into the DC input, P_{dc-in} , then equals to 2300 W. However, the power which was generated in the diode bridge is then equal to the subtraction between the AC input power and the DC input power, and $P_{diode-bridge}$ then equals 11 W.

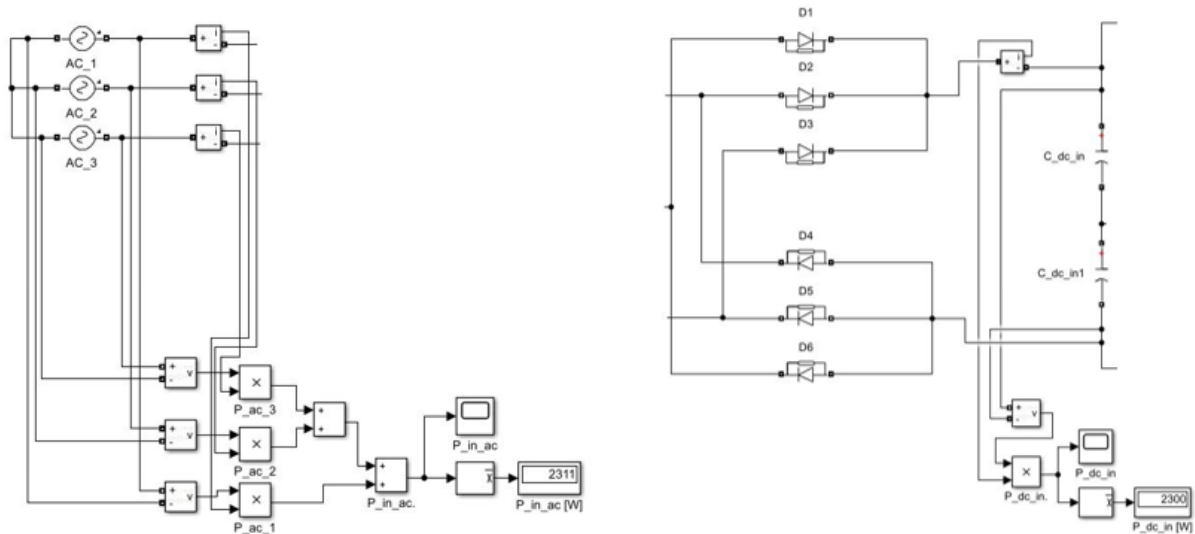

Figure 4.33: a) Shows the power measurement and the generated power for the AC sources

b) Shows the power measurement and the remaining power in the DC input after the diode bridge

Figure 4.34 a) shows how the power was measured for the two MOSFET switches in the circuit. The total power for the switches, $P_{switches}$, then equals approximately 3.7 W.

Further, Figure 4.34 b) shows how the remaining power was measured before the transformer and before the output circuit, as well as the measured power for the diodes after the transformer.

4 Modelling and Simulation of a DC Power Supply

The power into the transformer, $P_{\text{trafo-in}}$, then equals 2297 W, and the power into the output circuit, P_{oi} , equals 2134 W. The total power for the two diodes, P_{diodes} , then equals 95.6 W.

To find the power which was generated in the transformer itself, it was needed to subtract the power into the transformer with the power into the output circuit and the power generated in the diodes. The total power for the transformer, $P_{\text{transformer}}$, then equals 67.4 W. As the output/load power equals to 2125 W and the power into the output circuit equals 2134, it means that 9 W is lost between the diodes and the load.

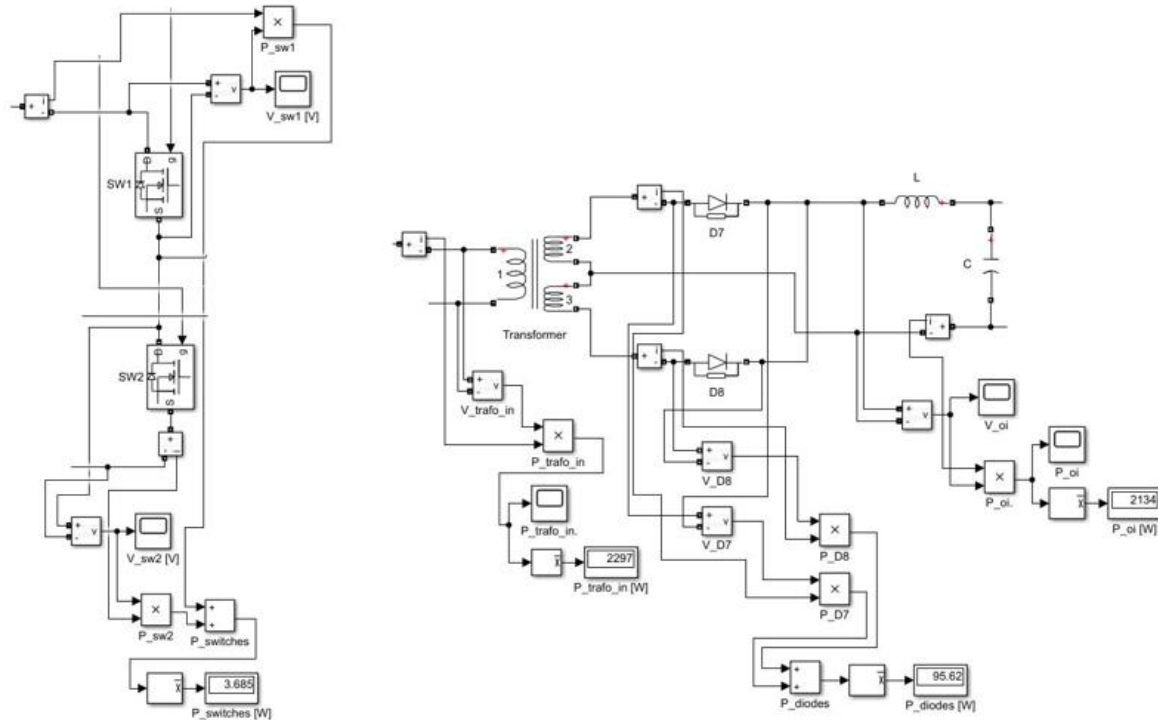

Figure 4.34: a) Shows the power measurement and the generated power for the switches

b) Shows the power measurement and the remaining power before the transformer, the remaining power before the output circuit, and the power generated for the diodes

The power loss in the half-bridge converter with electrical isolation is then given by

$$P_{\text{loss}} = P_{\text{diode_bridge}} + P_{\text{switches}} + P_{\text{transformer}} + P_{\text{diodes}} + P_{\text{output_circuit}} \quad (4.5)$$

where P_{loss} is the power loss, $P_{\text{diode-bridge}}$ is the power lost in the diode bridge, P_{switches} is the power lost in the switches, $P_{\text{transformer}}$ is the power lost in the transformer, P_{diodes} is the power lost in the diodes, and $P_{\text{output-circuit}}$ is the power lost in the output circuit.

By using Equation (4.5), the power loss then equals 186.7 W.

4 Modelling and Simulation of a DC Power Supply

When it comes to the efficiency of the half-bridge converter model, the calculation will be based on Equation (4.3). With an input power (from the AC sources) of 2311 W and an output/load power of 2125 W, the efficiency of the half-bridge model is then equal to 92 %.

A summary of the simulated and calculated power, loss and efficiency values in this part can be seen in Table 8.

Table 8: Shows the input power (from the AC sources), the output/load power, power loss and efficiency of the half-bridge converter model with electrical isolation

P_{in} [W]	P_{load} [W]	P_{loss} [W]	Efficiency, η [%]
2311	2125	186.7	92

4.6.5 Variation in AC Supply Voltage to the Power Supply

Variations in the AC supply voltage may affect the DC output of the power supply. Similarly, as for the other three models, the purpose is to observe what will happen to the DC output values at the load if the AC supply voltage increases or decreases according to the nominal input voltage of 230 V. The AC voltage sources will be increased by 10 %, which gives the new value for each of the AC sources to be 253 V.

By modifying the AC voltage sources in the Simulink model with the new voltage value, the results of the DC outputs both before and after the change can be seen in Table 9. It is to be noted that the duty cycle is not changed and is still 50 %.

Table 9: Shows the results in the DC outputs of the half-bridge converter model with isolation, both before and after changing the value of the AC supply voltage

AC voltage source [V]	V_{load} [V]	I_{load} [A]	P_{load} [W]
230	20.61	103.1	2125
253	22.36	111.8	2500

With an increase of 10 %, it can be seen that the DC output voltage changed with 1.75 V, the output current changed with 8.7 A, and the output power changed with 375 W. It will correspond to an increase in percentage of 8.5 %, 8.5 % and 17.6 % respectively.

As described for the first half-bridge converter in subchapter 4.5.5, by reducing and optimize the duty cycle, the output values can gain the desired output values, nevertheless the AC supply voltage will vary.

4.6.6 Discussion

The half-bridge converter in this section was based on the first half-bridge converter model in subchapter 4.5, and has improvements like adding a transformer to the circuit such that the input/mains and output circuit could be separated. This is due to that the components in the output circuit should be protected if there would be variations or a fault in the supply voltage, as well as the safety for the personnel which is a factor for having electrical isolation in the circuit.

One thing to notify is that the efficiency of the half-bridge converter model with electrical isolation, which was sectioned and connected in series, slightly decreased to 92 % compared to the first half-bridge converter which had an efficiency of 98.7 %. The converter is still quite effective and had a power loss of 186.7 W through the circuit.

However, regarding the switch utilization of the switches in the first half-bridge converter model, which was very poor, this will not be a problem for the half-bridge converter in this section as the switches have a duty cycle of 50 %, which corresponds to a better switch utilization according to Figure 3.5.

Another problem, likewise, as for the three other models, a variation in the AC supply voltage will affect the DC output values. When the AC voltage sources were increased with 10 %, the output voltage of the converter changed with 8.5 %. It means that the output voltage of this half-bridge model increased less than the increase of the AC supply voltage, compared to the other three models where the increase was at the same level or a higher difference at the input and output. Nevertheless, the output values should still not be changed due to variations in the AC supply voltage. Likewise, as for the first half-bridge model, an advantage is that the duty cycle can be adjusted to compensate for the input variations. The output values of the half-bridge model with electrical isolation may then be controlled by adding a PID controller such that it will control the duty cycle to give the correct output values independent of possible variations in the supply voltage.

With the additional requirement from the research group in subchapter 2.2, where the power supply may need to supply two different voltage levels during the operating process, the half-bridge converter model has an advantage regarding the control of the DC outputs. This is due to that the duty cycle can be adjusted and controlled, as for the section above, such that the DC output voltage will gain a desired voltage level during the operating process.

5 Commercial DC Power Supplies Suitable for a Laboratory Scale System

The research group for the biochemical system wants to find an optimal solution for a DC power supply which will supply the biochemical system with desired voltage- and current values. It is therefore of interest to investigate whether any commercial power supplies would be suitable for a laboratory scale system in case of availability in the market and the price level. This will be in addition to the design of a laboratory scaled power supply which has been developed in this thesis.

The design of the power supply in this thesis was designed for two levels of DC output values, one with an output voltage of 2 V and an output current of 1000 A, and one with an output voltage of 20 V and an output current of 100 A. Due to this, the availability of commercial power supplies will be investigated for the same levels of output values.

This chapter contains a research of the availability of DC power supplies regarding the stated output values, examples of commercial power supplies, and a discussion of the findings.

5.1 Research of Availability Regarding Different Output Values

A research was performed to figure out the availability due to the stated and desired DC output values.

According to this it turned out that the availability of power supplies which had desired DC output voltage of 2 V and output current of 1000 A were poor. The thesis writer was not able to find any standards of suitable power supplies due to the desired output values. Therefore, there will be no examples regarding these output values.

However, it turned out that it was difficult to find power supplies which had desired DC output voltage of 20 V and output current of 100 A as well. On the contrary, there were a greater availability of power supplies which had a standard output voltage of 24 V, and which could be found with an output current of 100 A. Therefore, it has been performed further research into power supplies with these output values.

There were not found a price estimate for every available power supply. Nevertheless, subsection 6.2 will provide some examples of commercial DC power supplies with output values of 24 V and 100 A.

It is to be notified that the search for DC power supplies narrowed into switch mode power supplies, as these showed out to be the regular ones to find. The supplier's web site which were visited in the research of different DC power supplies were Artesyn, Digi-Key Electronics, Elfa Distrelec, Farnell, and RS Components.

5.2 DC Power Supply Examples for Output Values of 24 V and 100 A

The findings from the research showed that there were a higher availability of DC power supplies with a standard voltage of 24 V, and further that it corresponded to the desired output current of 100 A. This subchapter will present two DC power supply models from two different manufacturers, one from Mean Well and one from Artesyn.

5.2.1 Mean Well RSP-2400-24

The first example of a commercial power supply is the RSP-2400-24 switch mode power supply, where the manufacturer is Mean Well. Three suppliers have the power supply model in their stock, which is Digi-Key Electronics, Elfa Distrelec and RS Components. Figure 5.1 shows a picture of the RSP-2400-24 power supply model. [10] [11] [12]



Figure 5.1: Mean Well RSP-2400-24 Switch Mode Power Supply [13]

RSP-2400-24 will supply a DC output voltage of 24 V, and has a rated output current of 100 A and a rated power of 2400 W. The input to the power supply has an AC voltage range of 180-264 V, and the DC output voltage has an adjustment range from 22-28 V. The efficiency of this model equals 90 %. [13]

The price estimates from the three suppliers of RSP-2400-24 can be seen in Table 10.

Table 10: Price estimates for Mean Well RSP-2400-24 Switch Mode Power Supply [10] [11] [12]

Supplier:	Digi-Key Electronics	Elfa Distrelec	RS Components
Price estimate:	4632 kr	3684 kr	5684 kr

5 Commercial DC Power Supplies Suitable for a Laboratory Scale System

5.2.2 Artesyn LCM3000Q-T

The second example of a commercial power supply is the LCM3000Q-T switch mode power supply, where the manufacturer is Artesyn. Two suppliers have the power supply model in their stock, which is Digi-Key Electronics and RS Components. Figure 5.2 shows a picture of the LCM3000Q-T power supply model. [14] [15]



Figure 5.2: Artesyn LCM3000Q-T Switch Mode Power Supply [16]

LCM3000Q-T will supply a DC output voltage of 24 V, and has a rated output current of 125 A and a rated power of 3000 W. The input to the power supply has an AC voltage range of 90-264 V, and the DC output voltage has an adjustment range of 24-30 V. The efficiency of this model equals 90 %. [16]

The price estimates from the two suppliers of LCM3000Q-T can be seen in Table 11.

Table 11: Price estimates for Artesyn LCM3000Q-T Switch Mode Power Supply [14] [15]

Supplier:	Digi-Key Electronics	RS Components
Price estimate:	7432 kr	7330 kr

5.3 Discussion

It can be seen that there were lack of available DC power supplies regarding output values with a voltage of 2 V and a current of 1000 A, as well as for the output values with a voltage of 20 V and a current of 100 A. However, DC power supplies with a standard output voltage of 24 V, and with a corresponding output current of 100 A, were available in place of the one with output values of 20 V and 100 A.

The two examples of a power supply model showed that the largest price difference between those two was a difference of nearly 4000 kr. In addition, it was a significantly price difference of 2000 kr between the same RSP-2400-24 model but from different suppliers. Therefore, it is a need of a proper research when searching for commercial power supply models.

6 Discussion

This chapter contains a main discussion of the results of the thesis, as well as a minor evaluating of the scalability for a 100 kW pilot setup.

6.1 Main Discussion

The first thing to discuss is the efficiency of the different DC power supply models which were modelled and simulated in Simulink. The first diode rectifier model which was connected directly had an efficiency of 29.4 %, while the second diode rectifier model where the load/MES was sectioned and connected in series had an efficiency of 86.2 %. The first and simpler half-bridge DC-DC converter which was sectioned and connected in series had an efficiency of 98.7 %, while the second half-bridge DC-DC converter with electrical isolation, which also was sectioned and connected in series, had an efficiency of 92 %. It shows that the power supply models which were connected in series obtained a significantly higher efficiency than the first rectifier model which was connected directly. This may be due to that the current was significantly decreased from 1000 A to 100 A, which further affects the losses in the circuit. Regarding the efficiency, the series connected rectifier would be preferred in case of the directly connected rectifier. However, even though the first half-bridge converter had a greater efficiency than the half-bridge converter with electrical isolation, it would be preferred to choose the second half-bridge converter due to the electrical isolation in the circuit. This is due to both component protection and safety for the personnel regarding the output circuit.

The second thing to discuss is control and regulation of the circuits. The two rectifier circuits are simple models of a power supply and may have complications, like a more complicated design of the transformer, due to missing regulation of the output voltage. This is due to mains/AC supply voltage variations or, as stated, that the biochemical system may require different voltage levels during operation.

Nevertheless, looking at the half-bridge converter circuits which consists of power electronic components, the output voltage will depend on the adjustment of the duty cycle of the PWM signal, which further controls the duration time of the switches. It means that the duty cycle can be controlled to keep the output voltage constant, whether it will be variations in the mains/AC supply voltage or, as stated, if the biochemical system will require two different voltage levels during the operating process. The advantage of the half-bridge converter models is that the duty cycle can be controlled and regulated by adding a PID controller such that the output voltage will be kept constant. Therefore, the half-bridge converter, preferably with electrical isolation, will be a good choice when choosing a design for a DC power supply. This is both due to its regulation opportunities, electrical isolation, and its high efficiency.

The third thing to discuss is the availability of commercial DC power supplies suitable for a laboratory scale system. The research study showed that there was a lack of availability for DC power supplies which had output values of 2 V and 1000 A. Compared to the design of the diode rectifier which was connected directly in subchapter 4.3, and which had a poor efficiency of 29.4 %, it may be discussed whether it will be a need of a proper research for commercial power supplies with these output values, or if this design of a power supply will be an acceptable choice at all.

However, the research study also showed that there was a lack of availability for DC power supplies which had output values of 20 V and 100 A. On the contrary, there was a greater availability of power supplies with a standard output voltage of 24 V, and with a corresponding output current of 100 A. Compared to the design of the power supply models which were connected in series in subchapter 4.4, 4.5 and 4.6, and which had an efficiency around 90 %, it can be seen that the efficiency coincide well with the efficiency of the commercial power supply which has an efficiency of 90 %. It is to be noted that the research study showed that switch mode power supplies seemed to be the regular ones when it comes to commercial power supplies. Due to this, it may be another guidance that switch mode power supplies with power electronic components, referred to the design of the half-bridge DC-DC converters in this thesis, seems to be a proper choice when it comes to choosing a suitable power supply model design for the biochemical system.

6.2 Evaluating the Scalability for a 100 kW Pilot Setup

As a part of the thesis, the scalability for a 100 kW pilot setup will be evaluated regarding the found solution for a laboratory scale setup.

It will be assumed that the scalability of the laboratory setup will increase linearly, which means that a pilot setup of 100 kW will be scaled up with a factor of 50 compared to the laboratory setup of 2 kW. It is intended that the output voltage would be the same as for the laboratory setup, and therefore using the value of 20 V for the power supplies which had a series configuration. Due to this, the output current will increase from 100 A to 5 kA.

The amount of current through a power supply has been discussed previously in the thesis, and with a higher current it will lead to higher losses in the circuit. The power supply may have the same efficiency as for the laboratory scale if it is increased linearly, but with the significantly increase in lost power in the circuit, it may lead to high amounts of heat in the power supply, which further means that there may be a need of more cooling components.

Another thing to consider concerning the increase in the current is related to the components in the circuit, and if they would withstand the increase. Probably, it will be a need of more powerful components. However, the increase in current will most probably affect the power cable as well, and it may be a need of a greater dimension of the cable, which further may lead to higher losses.

With these assumptions and discussion regarding the scalability from a laboratory scale setup to a pilot scale setup, it will be a need for a further research into the withstand of the components due to a significantly increase in the current, as well as the higher amount of power losses.

7 Conclusion

This chapter contains the main conclusion for the master's thesis, as well as suggestions for further work.

7.1 Main Conclusion

This Master's Thesis was established to design an optimal low-voltage high-power DC power supply which can feed a biochemical system in a laboratory scale setup.

Regarding the results of the thesis, there are several parts of a design of a power supply model which needs to be considered. These factors are due to efficiency, regulation opportunities and electrical isolation.

The results from the design of the different power supply models showed that it will be an advantage to connect the model in a series configuration, which in case of a higher voltage and a lower current is due to a higher efficiency and less power losses in the circuit. Both the diode rectifier with a series configuration and the two half-bridge DC-DC converters obtained a high efficiency of 86.2 %, 98.7 % and 92 % respectively.

The regulation opportunities for the different models showed that it will be simpler and more accurate to regulate a half-bridge DC-DC converter than a diode rectifier model, which is due to the power electronic components in a half-bridge converter. The output values of the half-bridge converter can be easily regulated and kept constant by adding a PID controller, such that it can adjust the duty cycle to compensate for variation in the mains/AC supply voltage or if the system require two different voltage levels during the operating process.

Furthermore, it is stated that a DC power supply may require an electrical isolation (isolation transformer) in the circuit, which is due to component protection and safety for the personnel regarding the output circuit. Both the diode rectifier circuit and the second half-bridge DC-DC converter cover this recommendation or requirement.

When it comes to the commercial DC power supplies, the research study showed that there was a greater availability for power supplies with output values of 24 V and 100 A (the closest choice for desired output values of 20 V and 100 A) than for power supplies with output values of 2 V and 1000 A. In addition, it also showed that switch mode power supplies were the regular ones to find.

Due to these stated results, the main conclusion for the thesis concludes that a switch mode DC power supply would be a proper choice to implement to the biochemical system in case of a great efficiency and regulation opportunities, as well as the switch mode power supplies were the regular ones to find for commercial coherence, if that would be a design choice for the research group. The design of the half-bridge DC-DC converter with electrical isolation in this thesis, which had a series configuration, will then be the recommended choice for an optimal low-voltage high-power DC power supply which can be connected to the biochemical system.

7.2 Further Work

Based on the findings in this thesis, there will be suggested a further research of some parts of the thesis.

Subchapter 4.2.3 stated that the power loss for the switch components in the half-bridge DC-DC converter only contained conduction losses due to lack of methods for how to measure switching losses for the switches in Simulink. Therefore, the switching losses were not investigated in this thesis, whereas it should be considered when the power losses are measured or calculated. The switching losses should therefore be a part of a further research.

Furthermore, the DC output waves, which are the results of the output values of a DC power supply, may experience some variation in its output waves due to not good enough filtering of the ripple voltage which comes from the rectifying of the AC voltage, or it may be other causes. The question is related to whether the biochemical system can tolerate small variations in the DC waves, or if the DC waves should be completely smooth. A further research of the DC wave variations is suggested.

Another question is related to whether the biochemical system actually perform as desired when connecting a power supply to cells connected in a series configuration instead of having a directly connected power supply to each cell in the biochemical system. The theoretical purpose is fulfilled in this thesis regarding that the power supply with a series configuration had a higher efficiency and minor losses in the circuit. A further research should be performed.

The examples of commercial power supplies showed that there was a standard for the output voltages for most of the power supplies. It means that it will be more difficult to find DC power supplies which have an output voltage of 20 V, as this thesis has applied in the design of the circuits. A further research may consider whether the design of a power supply could have 12 cells in series, as an example, such that it will provide 24 V. The examples of commercial power supplies presented earlier have a voltage adjustment range of 22-28 V and 24-30 V, respectively. The requirement for voltage range is also a subject for further investigations.

Furthermore, as it was discussed that the half-bridge DC-DC converter could be regulated by adding a PID controller to the circuit, the implementation of the PID controller should be a part of a further work on the design part.

Finally, there should be performed a further research into the larger pilot setup, as this was a minor part and slightly discussed in the thesis.

References

- [K. Rabaey, A. Johnstone, A. Wise, S. Read and R. Rozendal, "Microbial electrosynthesis: 1 from electricity to biofuels and biochemicals," *BIOTECH International*, vol. 22, June] 2010.
- [U. Schröder, F. Harnisch and L. Angenent, "Microbial Electrochemistry and Technology: 2 Terminology and Classification," *Energy & Environmental Science*, vol. 8, no. 2, pp. 513-] 519, 2015.
- [M. Shemfe, K. Ng and J. Sadhukhan, "Bioelectrochemical Systems for biofuel (electricity, 3 hydrogen, and methane) and valuable chemical production," in *Green Chemistry for] Sustainable Biofuel Production*, Apple Academic Press, 2017, p. Chapter 14.
- [Electronics Club, "Power Supplies," [Online]. Available: 4 <https://electronicsclub.info/powersupplies.htm>. [Accessed 4 April 2020].]
- [N. Mohan, T. Undeland and W. Robbins, *Power Electronics - Converters, Applications, 5 and Design*, 3. ed., John Wiley & Sons, 2003.]
- [MathWorks, "Diode," 2020. [Online]. Available: 6 https://se.mathworks.com/help/physmod/sps/powersys/ref/diode.html?s_tid=srchtitle.] [Accessed 3 May 2020].
- [MathWorks, "Three-Phase Transformer 12 Terminals," 2020. [Online]. Available: 7 [https://se.mathworks.com/help/physmod/sps/powersys/ref/threephasetransformer12termin \] als.html?s_tid=srchtitle](https://se.mathworks.com/help/physmod/sps/powersys/ref/threephasetransformer12termin als.html?s_tid=srchtitle). [Accessed 3 May 2020].
- [MathWorks, "Linear Transformer," 2020. [Online]. Available: 8 https://se.mathworks.com/help/physmod/sps/powersys/ref/lineartransformer.html?s_tid=srchtitle.] [Accessed 3 May 2020].
- [MathWorks, "MOSFET," 2020. [Online]. Available: 9 https://se.mathworks.com/help/physmod/sps/powersys/ref/mosfet.html?s_tid=srchtitle.] [Accessed 3 May 2020].
- [Digi-Key Electronics, "RSP-2400-24," 2020. [Online]. Available: 1 [https://www.digikey.no/product-detail/no/mean-well-usa-inc/RSP-2400-24/1866-4256- \] 0 ND/7706320](https://www.digikey.no/product-detail/no/mean-well-usa-inc/RSP-2400-24/1866-4256-0 ND/7706320). [Accessed 5 May 2020].
- [Elfa Distrelec, "RSP-2400-24 - Switch-Mode strømforsyning," 2020. [Online]. Available: 1 [https://www.elfadistrelec.no/no/switch-mode-stromforsyning-4kw-24v-100a-mean-well- \] 1 rsp-2400-24/p/16905971?q=* &pos=3&origPos=747&origPageSize=10&track=true](https://www.elfadistrelec.no/no/switch-mode-stromforsyning-4kw-24v-100a-mean-well-rsp-2400-24/p/16905971?q=* &pos=3&origPos=747&origPageSize=10&track=true).] [Accessed 5 May 2020].

References

- [RS Components, "Mean Well, 2.4 kW Embedded Switch Mode Power Supply SMPS,"
1 2020. [Online]. Available: [https://no.rs-online.com/web/p/embedded-switch-mode-power-](https://no.rs-online.com/web/p/embedded-switch-mode-power-supplies-smps/7059872/)
2 [supplies-smps/7059872/](https://no.rs-online.com/web/p/embedded-switch-mode-power-supplies-smps/7059872/). [Accessed 5 May 2020].
]
- [MEAN WELL, "2400W Single Output Power Supply - datasheet," [Online]. Available:
1 [https://www.elfadistrelec.no/Web/Downloads/he/et/RSP2400_eng_datasheet.pdf?pid=\\${p](https://www.elfadistrelec.no/Web/Downloads/he/et/RSP2400_eng_datasheet.pdf?pid=${product.code})
3 [roduct.code}](https://www.elfadistrelec.no/Web/Downloads/he/et/RSP2400_eng_datasheet.pdf?pid=${product.code}). [Accessed 5 May 2020].
]
- [Digi-Key Electronics, "LCM3000Q-T," 2020. [Online]. Available:
1 [https://www.digikey.no/product-detail/en/artesyn-embedded-power/LCM3000Q-T/454-](https://www.digikey.no/product-detail/en/artesyn-embedded-power/LCM3000Q-T/454-1945-ND/6133906?_ga=2.193351469.184839573.1589362913-729210778.1589362913)
4 [1945-ND/6133906?_ga=2.193351469.184839573.1589362913-729210778.1589362913.](https://www.digikey.no/product-detail/en/artesyn-embedded-power/LCM3000Q-T/454-1945-ND/6133906?_ga=2.193351469.184839573.1589362913-729210778.1589362913)
] [Accessed 5 May 2020].
- [RS Components, "Artesyn Embedded Technologies, 3kW Embedded Switch Mode Power
1 Supply," 2020. [Online]. Available: [https://no.rs-online.com/web/p/embedded-switch-](https://no.rs-online.com/web/p/embedded-switch-mode-power-supplies-smps/1799554/?relevancy-data=636F3D3126696E3D4931384E53656172636847656E65726963266C753D6E6F266D6D3D6D61746368616C6C7061727469616C26706D3D5E5B5C707B4C7D5C707B4E647D2D2C2F255C2E5D2B2426706F3)
5 [mode-power-supplies-smps/1799554/?relevancy-](https://no.rs-online.com/web/p/embedded-switch-mode-power-supplies-smps/1799554/?relevancy-data=636F3D3126696E3D4931384E53656172636847656E65726963266C753D6E6F266D6D3D6D61746368616C6C7061727469616C26706D3D5E5B5C707B4C7D5C707B4E647D2D2C2F255C2E5D2B2426706F3)
] [data=636F3D3126696E3D4931384E53656172636847656E65726963266C753D6E6F266](https://no.rs-online.com/web/p/embedded-switch-mode-power-supplies-smps/1799554/?relevancy-data=636F3D3126696E3D4931384E53656172636847656E65726963266C753D6E6F266D6D3D6D61746368616C6C7061727469616C26706D3D5E5B5C707B4C7D5C707B4E647D2D2C2F255C2E5D2B2426706F3)
D6D3D6D61746368616C6C7061727469616C26706D3D5E5B5C707B4C7D5C707B4E6
47D2D2C2F255C2E5D2B2426706F3. [Accessed 5 May 2020].
- [Artesyn, "LCM3000 - Data Sheet," [Online]. Available:
1 https://www.artesyn.com/assets/lcm3000_ds_06aug2018_1533580068.pdf. [Accessed 5
6 May 2020].
]

Appendices

Appendix A: Original problem description for this Master's Thesis

USN University of
South-Eastern Norway
Faculty of Technology, Natural Sciences and Maritime Sciences, Campus Porsgrunn

FMH606 Master's Thesis

Title: Design of a low-voltage high-power DC power supply for microbial electrochemical synthesis

USN supervisor: Kjetil Svendsen

External partner: -

Task background:

Microbial electrochemical synthesis (MES) is a novel technology combining electrical, environmental and chemical engineering disciplines. MES is a power to gas technology that seeks to convert carbon dioxide (CO₂) into organics that can be used as fuels or building blocks for new products to replace the use of fossil oil and gas. We have demonstrated such experimentally by biogas upgrading where biogas CO₂ is reduced to methane (CH₄), to increase the methane content in biogas produced by treatment plants. It uses electricity as an energy source and microorganisms as the catalyst for the chemical reduction reaction (CO₂ to CH₄) at the cathode in a methane-producing microbial electrolysis cell (MEC). This (thesis) task focuses on electricity/power supply to such a MEC with multiple electrodes installed in a single reactor compartment. USN has bioelectrochemistry as a research focus. USN has published research work and has laboratory facilities that will be the baseline for this project.

Task description:

Establish the framework and main parameters for power supply to a MEC connected to an existing Anaerobic Digestion (AD) plant.

As part of the thesis a low-voltage high-power DC power supply shall be designed:

- Literature research into most common available types of power-supply solutions
- Design a power supply that can be used for a small-scale laboratory setup (size to be determined in cooperation with students and staff working on other design aspects)
- Modelling and simulation of the power supply with a simulation software
- Investigate critical building blocks for the laboratory scale power supply
- Investigate availability of commercial power supplies suitable for this application
- Evaluating the scalability of the found solution for a 100 kW pilot setup
- Estimate the energy efficiency for different solutions, such as at different voltage levels

Student category: EPE

Practical arrangements: -

Supervision:

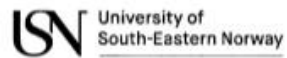

Faculty of Technology, Natural Sciences and Maritime Sciences, Campus Porsgrunn

As a general rule, the student is entitled to 15-20 hours of supervision. This includes necessary time for the supervisor to prepare for supervision meetings (reading material to be discussed, etc).

Signatures:

Supervisor (date and signature): 3.2.20 

Student (write clearly in all capitalized letters): VILDE SUNDLING

Student (date and signature): 3/2-20 