

# Modified Smith-predictor multirate control utilizing secondary process measurements

Rolf Ergon

---

## Abstract

The Smith-predictor is a well-known control structure for industrial time delay systems, where the basic idea is to estimate the non-delayed process output by use of a process model, and to use this estimate in an inner feedback control loop combined with an outer feedback loop based on the delayed estimation error. The model used may be either mechanistic or identified from input-output data. The paper discusses improvements of the Smith-predictor for systems where also secondary process measurements without time delay are available as a basis for the primary output estimation. The estimator may then be identified also in the common case with primary outputs sampled at a lower rate than the secondary outputs. A simulation example demonstrates the feasibility and advantages of the suggested control structure.

*Keywords:* Smith-predictor, secondary outputs, multirate control

---

## 1 Introduction

Time delay systems are frequently encountered in industrial control practice, and use of a Smith-predictor structure is a well known strategy to follow (Seborg et al., 1989). The basic idea is then to use a process model to obtain an estimate of the non-delayed system output to be used in an inner feedback loop, combined with an outer feedback loop based on the delayed estimation error. The model used may be either mechanistic or identified from input-output data.

In many industrial cases the process under control has one primary output measurement  $y_1(k)$  with a time delay, and several secondary measurements  $y_2(k)$  without time delays. As indicated in Figure 1, the measurements  $y_2(k)$  may together with the controller output  $u(k)$  be used as inputs to an estimator for the primary property  $z(k)$  without time-delay. The estimator thus replaces the traditional Smith-predictor model. Since the secondary measurements may carry valuable information about the process disturbance  $v(k)$ , the estimate  $\hat{z}(k)$  may be considerably improved by use of the additional  $y_2(k)$  information. The estimator may be designed on the basis of a mechanistic process model, including known noise covariances. It may, how-

ever, be more conveniently identified from experimental input-output process data. Feedback or feedforward of  $y_2(k)$  may also be incorporated in the control structure.

In Figure 1 the noise sources  $v(k)$ ,  $w_1(k)$  and  $w_2(k)$  are assumed to be white. This is often a reasonable assumption for the measurement noise, while the process noise  $v(k)$  may have to be modeled as filtered white noise, with the filter included in the process model.

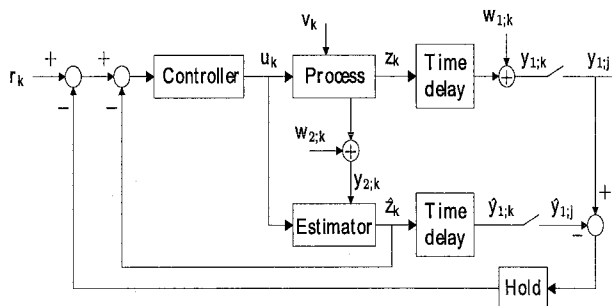

Figure 1: Modified Smith-predictor multirate control utilizing secondary process measurements.

As also indicated in Figure 1 the primary output will in many cases be sampled at a low and possibly also irregular rate, i.e.  $y_1(j)$  may be just some of the high sampling rate  $y_1(k)$  values. This is typically the case for product quality measurements, where physical sampling and, e.g., chemical analysis are necessary. A low primary output sampling rate makes it necessary with a hold function in the outer feedback loop. Alternatively, the  $y_1(j)$  measurements may be compared with the corresponding  $r(j)$  reference values in an outer feedback loop with integral action.

## 2 Estimator identification

Identification of the estimator from experimental data with both  $y_2(k)$  and  $u(k)$  as inputs may be performed by use of a prediction error method based on an underlying Kalman filter (Ljung, 1995). The time delay is then simply removed by appropriate data shifting. In order to obtain a theoretically optimal solution an output error (OE) structure must be specified (Ergon, 1999a), although also an ARMAX structure or a subspace identification method may provide good enough results for practical use. The argument for an OE structure is that neither past nor present non-delayed  $y_1(k)$  values will be available during normal operation, and in order to obtain correct Kalman gains they should thus not be used in the identification stage. The identification is straightforward when  $y_1(k)$  values are available at the same high rate as  $y_2(k)$  and  $u(k)$ , and the prediction error method can also be modified to handle the low and even irregular primary output sampling rate case (Ergon, 1998). We then minimize the criterion function

$$V_N(\theta) = \frac{1}{N} \sum_{j=1}^N [y_1(j) - \hat{y}_1(j)]^2, \quad (1)$$

where  $N$  is the number of  $y_1(j)$  samples in the modeling set.

In the low primary output sampling rate case it is still required that  $y_2(k)$  and  $u(k)$  are sampled often enough in order to capture the dynamics of the process, and we thus have a multirate sampling identification problem. The standard initial value procedure based on a least squares identification of an ARX model cannot then be used, and we have to resort to some ad hoc initial value method (Ergon, 1999b). It is also required that the  $y_1(j)$  data are representative, with the same statistical distribution as  $y_1(k)$ . Further note that minimization of (1) in the multirate case is possible only for the OE structure, i.e. theoretical optimality coincides with practical feasibility.

## 3 Simulated system

Figure 2 shows a two-stage stirred-tank mixing process where the feed flow rate  $q_F = 2 \text{ m}^3/\text{min}$ . is constant, while the

feed concentration  $c_F(t)$  [ $\text{kg}/\text{m}^3$ ] varies around  $50 \text{ kg}/\text{m}^3$ . The flow rate  $q_A(t) = u(t)$  [ $\text{m}^3/\text{min}$ .] is the manipulated input from the controller, while  $c_A = 800 \text{ kg}/\text{m}^3$  is constant. The volumes are  $V_1 = 4 \text{ m}^3$  and  $V_2 = 3 \text{ m}^3$ , and  $x_1(t)$  and  $x_2(t)$  are the concentrations in the tanks. The primary output concentration  $x_1(t)$  is measured by a high quality analytical instrument, causing a time delay  $D = 10 \text{ min}$ . and requiring a corresponding sampling interval, while  $x_2(t)$  is measured by an instrument without time delay, but with more measurement noise. The transportation time between the tanks is considered negligible.

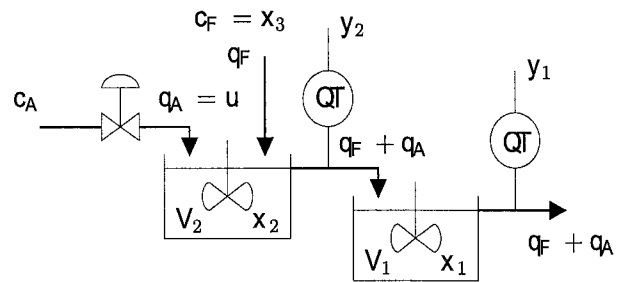

Figure 2: Two-stage stirred-tank mixing process in simulation example.

The time varying feed concentration  $c_F(t) = x_3(t)$  is modeled as

$$\dot{x}_3 = -a[x_3(t) - 50] + v(t), \quad (2)$$

where  $a = 0.05 \text{ min}^{-1}$  and  $v(t)$  is white noise. After an Euler discretization with sampling interval  $T$ , the discrete-time nonlinear process model is

$$\begin{aligned} x_1(k+1) &= \left[1 - \frac{Tq_F}{V_1}\right] x_1(k) + \frac{Tq_F}{V_1} x_2(k) \\ &\quad + \frac{T}{V_1} u(k) [x_2(k) - x_1(k)] \\ x_2(k+1) &= \left[1 - \frac{Tq_F}{V_2}\right] x_2(k) + \frac{Tq_F}{V_2} x_3(k) \\ &\quad - \frac{T}{V_2} u(k) x_2(k) + \frac{Tc_A}{V_2} u(k) \\ x_3(k+1) &= [1 - Ta] [x_3(k) - 50] + v(k) \\ y_1(k) &= x_1(k) + w_1(k) \\ y_2(k) &= x_2(k) + w_2(k), \end{aligned} \quad (3)$$

where the sample rate is chosen as  $T = 0.5 \text{ min}$ ., and where  $v(k)$ ,  $w_1(k)$  and  $w_2(k)$  are white and independent noise sequences with variances chosen as  $r_v = 0.02$ ,  $r_1 = 0.0001$  and  $r_2 = 0.01$ .

The process was controlled as shown in Figure 1, using a

proportional-integral controller given by

$$\begin{aligned} e(k) &= r(k) - y_1(k) + \hat{y}_1(k) - \hat{z}(k) \\ u(k) &= u_0 + K_p \left[ e(k) + \frac{T}{T_i} \sum_{i=1}^k e(i) \right], \end{aligned} \quad (4)$$

where  $u_0 = 0.1429$ , and where the controller parameters were chosen as  $K_p = 0.004$  and  $T_i = 34$  min., based on some trial and error starting with the Ziegler-Nichols continuous cycling method (Seborg et al., 1989). For simplicity of notation, (4) assumes high rate sampling of the primary output, and must thus be appropriately altered in the multirate case, i.e. by using the output from the hold function in Figure 1 instead of  $y_1(k) - \hat{y}_1(k)$ .

## 4 Identification of estimator

The process in Figure 2 was simulated according to (3), and the estimator in Figure 1 was then identified from input-output data. For comparison purposes three different estimators were identified by use of the System Identification Toolbox in Matlab (Ljung, 1995):

- An ordinary second-order Smith-predictor using  $u(k)$  only as input and  $y_1(k)$  as output was identified by use of the *armax* function. The number of samples was in this case  $N = 400$ .
- A modified second-order Smith-predictor using both  $u(k)$  and  $y_2(k)$  as inputs and  $y_1(k)$  as output was identified by use of the function *pem*, with an OE model specified, and with  $N = 400$ .
- Finally, a modified second-order Smith-predictor using low sampling rate data  $y_1(j)$  as output was identified by a modified *pem* function minimizing (1). The  $y_1(j)$  sampling interval was in this case  $T_1 = 20T = 10$  min., i.e. the same as the time delay  $D = 10$ . The number of  $u(k)$  and  $y_2(k)$  samples was  $N_2 = 8000$ , i.e. the number of  $y_1(j)$  samples was  $N = 400$ .

In all cases the input was a filtered pseudo-random binary sequence (PRBS) with autocovariance  $r_u(p) = 0.0016 \cdot (0.8)^{|p|}$ . The initial value problem in the multirate sampling case was solved by first identifying an ARMAX model with  $u(k)$  as input and  $y_2(k)$  as output, and then finding the static relation between the model state  $x(j)$  and the primary output  $y_1(j)$  by an ordinary least squares (LS) method. After an appropriate similarity transformation, this gives an initial model for the OE estimator to be identified (Ergon, 1999b). Typical validation responses for this procedure are shown in Figure 3.

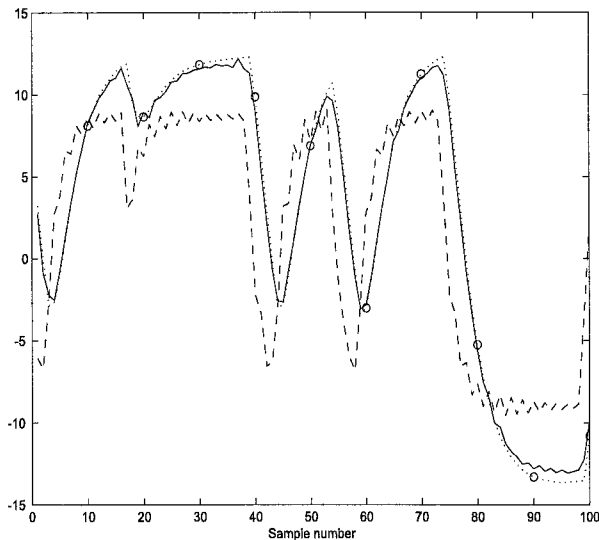

Figure 3: Segment of  $y_1(k)$  validation responses (centered data) for initial ARMAX+LS estimator (dashed line) and final OE estimator (solid line) in the multirate identification case. The ideal response is shown by dotted line with o-markings at the  $j$  sampling instants.

## 5 Simulation results

Simulation results for the control structure in Figure 1 with the process in Figure 2 and the identified estimators are shown in Figure 4a, b and c. Each typical RMSE value is based on 100 Monte Carlo runs, and computed according to

$$RMSE = \sqrt{0.001 \sum_{k=501}^{1500} [r(k) - y_1(k)]^2}. \quad (5)$$

Note that in the simulation  $y_1(k)$  is known also in the low sampling rate case

For the specific process in Figure 2, the control can also be based on feeding back the  $y_2(k)$  signal instead of the  $\hat{z}(k)$  estimate, and holding only  $y_1(j)$  (Figure 4d). The best result is in fact achieved by feedback of both  $y_2(k)$  and the  $\hat{z}(k)$  estimate (Figure 4e). These control structures using feedback of  $y_2(k)$  requires  $2r(k)$  as set point.

## 6 Conclusions

The modified Smith-predictor using also the secondary measurement information results in a considerably improved control performance, as compared with an ordinary Smith-predictor control structure. The primary output estimator may be identified from recorded data also in the multirate case with low primary output sampling rate. The modified

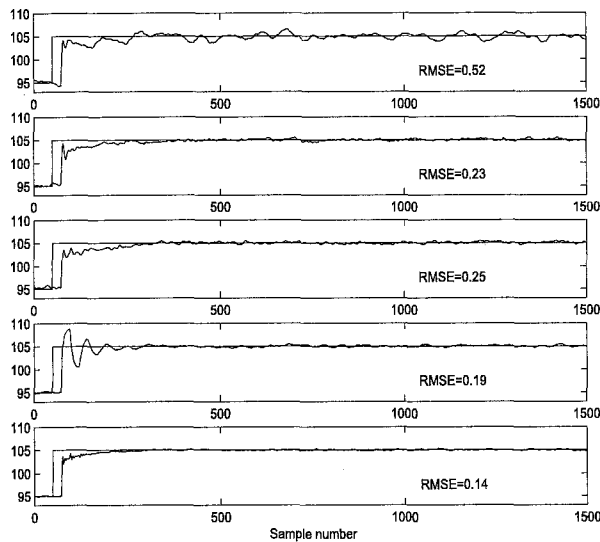

Figure 4: Step responses for different control structures (with typical RMSE values based on 100 Monte Carlo runs):

- a) Ordinary Smith-predictor control ( $RMSE = 0.52$ )
- b) Modified Smith-predictor control ( $RMSE = 0.23$ )
- c) Modified Smith-predictor control with low primary output sampling rate ( $RMSE = 0.25$ )
- d) Same as c) but feedback of  $y_2(k)$  instead of the  $\hat{z}(k)$  estimate, and holding  $y_1(k)$  only ( $RMSE = 0.19$ )
- e) Same as c) but feedback of  $y_2(k)$  in addition to the  $\hat{z}(k)$  estimate ( $RMSE = 0.14$ ).

Smith-predictor control structure in the simulation example essentially keeps its good performance also when the primary output sampling interval is twenty times the ordinary sampling interval, and much longer than what is apparently necessary in order to capture the dynamics in the system. In the specific simulation example, additional improvement was achieved by also feeding back the secondary measurement.

## References

- Seborg D.E., Edgar T.F. and Mellichamp D.A. *Process Dynamics and Control*. Wiley, 1989.
- Ljung L. *System Identification Toolbox for Matlab*. The MathWorks Inc., 1995.

Ergon R. On primary output estimation by use of secondary measurements as input signals in system identification. *IEEE Trans. Autom. Control*, 1999a. Vol. 44, 821-825

Ergon R. Dynamic system calibration: The low primary output sampling rate case. *Modeling, Identification and Control*, 1998. 19:99-107

Ergon R. Dynamic System Multivariate Calibration for Optimal Primary Output Estimation. PhD thesis, the *Norwegian University of Science and Technology/Telemark University College*, Trondheim/Porsgrunn, Norway, 1999b.