

Sensur av hovedoppgaver

Høgskolen i Buskerud og Vestfold
Fakultet for teknologi og maritime fag



Prosjektnummer: **2014-15**

For studieåret: **2013/2014**

Emnekode: **SFHO3201**

Prosjektnavn

Gass turbin eksos kasse

Gas turbine Exhaust Collector

Utført i samarbeid med: Dresser-Rand AS.

Ekstern veileder: Øivind Eidsmoen

Sammendrag: Vi har modellert en ny type eksos kasse for Dresser-Rand AS.

Resultatet ble en hybrid kassen som gjør det mulig og transportert driver pakken på jernbane gjennom det russiske kontinentet.

Stikkord:

- Eksos kasse
- Gass turbin
- Nytt konsept

Tilgjengelig: DELVIS

Prosjekt deltagere og karakter:

Navn	Karakter
David Lybek	

Dato: 12. Juni 2014

Frank Helgestad
Intern Veileder

Karoline Moholth
Intern Sensor

Øivind Eidsmoen
Ekstern Sensor

GR 15 DRESSER RAND EXHAUST CASE STUDY
PROJECT PLAN

Version 003

Author: David Lybek

26. May.2014

DRESSER RAND EXHAUST CASE STUDY

Document revision history

Version #	Design By	Revision Date	Approve By	Approval Date	Reason
001	<i>DLY</i>	<i>09.feb.14</i>	<i>DLY</i>	<i>09.FEB.14</i>	Initial draft
Comment to rev 002	DLY	09.feb.14	GN	09.apr 14	Added discussion about project model
002	GN	09.feb.14	GN	09.apr 14	Revised project plan to rev 002 not finished
003	DLY	26.may.14	DLY	26.may.14	Revised project plan to rev 002

Fig 1 Document revision history

DRESSER RAND EXHAUST CASE STUDY

Contents

1	SCOPE OF DOCUMENT	5
1.1	Introduction	5
2	ORGANIZATION, INTERACTION AND ADMINISTRATION OF RESOURCES	6
2.1	The group	6
2.2	Project Assigner.....	6
2.2.1	Supervisors from Dresser-Rand AS	7
2.2.2	Experts from Dresser-Rand	7
2.2.3	HBV (Høgskolen I Buskerud og Vestfold)	7
2.2.4	Supervisor from HBV	7
2.2.5	Examiners	8
2.2.6	Other resources.....	8
2.3	Group leader.....	9
2.4	Project engineer	10
3	THE PROJECT GOAL	11
3.1	The Problem	11
3.2	Topic question / Research question / Problemstilling	11
3.2.1	Definitions.....	11
3.3	Limitation on work and scope	13
3.4	Assumptions	13
3.5	System evaluation	14
3.6	Goals.....	14
3.6.1	Results for student	14
3.6.2	Effects for student.....	14
3.6.3	Results for DR	15
3.6.4	Effects for DR	15
3.7	Challenges	15
4	PROJECT MODEL.....	16
4.1	Sequential models.....	16
4.1.1	Water fall model.....	16
4.2	Evolutionary project models.....	17
4.2.1	Incremental model	17
4.3	Our hybrid project model.	19
4.4	Concerns.....	20
5	PROJECT STAGES AND ACTIVITY BREAK DOWN	21
5.1	Defining need	21
5.2	Engineering	22
5.3	Design	23
5.4	Review and test.....	23
5.5	Delivery and lessons learned	24
5.6	Tasks.	24
	Appendix A: References	26

DRESSER RAND EXHAUST CASE STUDY

This page is intently left blank

DRESSER RAND EXHAUST CASE STUDY

1 SCOPE OF DOCUMENT

The purpose of this document is to show and document to HBV, how and what we are going to do in in the final BSc project.

1.1 Introduction

Gas turbines are used in a wide variety of applications, from jet aircraft and power generation to marine propulsion.

Dresser-Rand AS designs and manufactures turbine driven generators and compressor packages, for offshore and onshore applications.

Some of these packages are powered by an industrialized version of General Electric CF6 aircraft engine known as the LM2500.

The power delivering components of the system are:

1. - A gas generator.
2. - A power turbine.

Coupled together these two components are called a Gas turbine.

These packages are mainly used to produce 3 things:

1 Mechanical power

The power turbine in this application is coupled to a compressor.

2 Electrical power

In this application the power turbine is coupled to a generator

3 Heat

In this system, the power turbine is coupled to either a generator or a compressor, but the used combustion gas is utilized further in the production of oil and gas. Either directly or through a heat exchanger

All of these systems result in a very high exhaust gas flow out of the Gas turbine,

The temperature could reach up to 550 degrees Celsius and in the range of 65 to 85 kg/sec.

All of these production capabilities are delivered from Dresser-Rand.

Dresser- Rand Kongsberg have in the past had problems delivering these packages to the Russian market, because of the transport constraints put on the size of the packages due to train transport to sites inside the Russian continent.

DRESSER RAND EXHAUST CASE STUDY

2 ORGANIZATION, INTERACTION AND ADMINISTRATION OF RESOURCES

2.1 The group

The project group consists of 2 bachelor students from HBV and they are:

David Lybek as project engineer

E-post: Davidlybek@yahoo.no

TLF: 90083297

Positions hold

Industrial mech.	1997-2001
Technical responsible.	2001-2003
Technician	2003-2004
Engineer at Devotek	2008-present

Education taken

Handel og kontor	1995
Grunnfag bed øk.	1996
Fagbrev	2003
Fagskole Ing.	2008
BCs	2014

Godwin Narnor as group leader

E-post: godwin.narnor@gmail.com

TLF: 96989847

Experience:

Positions held:

Test lab engineer at Constructor, Hønefoss
Draughtsman at AC Marine, Oslo
Draughtsman at Toptemp engineering, Oslo
Draughtsman at Ingenius, Drammen

Schools attended:

Kaneshie Sec. Tech. & Accra Polytechnic, Ghana
NIH
TIH
HIBU, Norway

2.2 Project Assigner

Øyvind Eidsmoen with the approval from Dresser-Rand ASA HR department.

Contact details.

Dresser-Rand AS

Kirkegårdsveien 45

3616 Kongsberg

Norge

TLF +47 32 28 70 70

Mail: OEidsmoen@Dresser-Rand.com

DRESSER RAND EXHAUST CASE STUDY

To regulate the relationship between the project group, HIBU and Dresser-Rand, the standard contract from HIBU has been used.
With the necessary adjustments to “non-disclosure” politic, confidentiality and ownership of study results.
See attachment 1 Contract

2.2.1 Supervisors from Dresser-Rand AS

Øyvind Eidsmoen.
Contact info: See above

Svein Y Jacobsen
Contact details.
Dresser-Rand AS
Kirkegårdsveien 45
3616 Kongsberg
Norge
TLF +47 32 28 70 70
E-mail: SJacobsen@Dresser-Rand.com

2.2.2 Experts from Dresser-Rand

Torun Jensen
Contact details.
TLF +47 32 28 70 70
E-mail: TJensen@Dresser-Rand.com

Thuy Vu Vuong
Contact details.
TLF +47 32 28 70 70
E-mail: TVuong@Dresser-Rand.com

2.2.3 HBV (Høyskolen I Buskerud og Vestfold)

For HBV to have some oversight of the project execution and progress, they have assigned a “veileder”/ supervisor.

The main roll for the HBV supervisor is to participate in the supervising meeting to track progress.

The supervisor will also be a part of the examination group who will set the group grade and the individual grade on each group member.

2.2.4 Supervisor from HBV

Frank Helgestad
E-mail: Frank.Helgestad@hbv.no

DRESSER RAND EXHAUST CASE STUDY

2.2.5 Examiners

To evaluate the project execution and the project deliverables, there will be an examination group. This group will consist of the external supervisor, the internal supervisor, and an internal examiner. This group is the group which will, sett the final grade on the project execution

From Dresser-Rand AS
Øyvind Eidsmoen.
Contact info: See above

From HIBU
Frank Helgestad
E-mail: Frank.Helgestad@hbv.no

Karoline Mohlloth
E-mail: karoline@moholth.com

To regulate internal work and processes the group has to sign this document.
See last page

The project organisation and how they relate to each other is described in the organisation chart below.

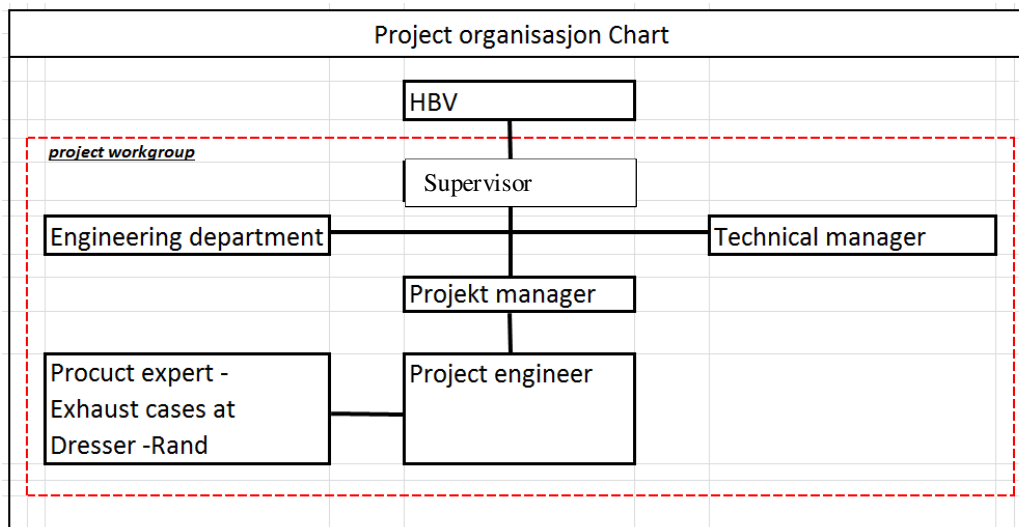

Fig 01 project organisation

2.2.6 Other resources

There are also other people participating and contributing to this project but to what extend is still not known so they will not be mentioned

DRESSER RAND EXHAUST CASE STUDY

Since the project only consists of 2 students there will only be 2 different rolls described.

2.3 Group leader by Godwind Narnor

This role is the overall responsible for the project progress. And have the responsibility for initialising the supervising meeting with the HBV supervisor.

This includes:

1. - Writing the "Oppfølgings document".
- 2.-The MOM form the last meeting
- 3.-And to collect the timesheets from the group, and organise these document in an understandable and logical manner, so it is easy to see and understand the progress of the project.

This role also has the main responsibility to keep the main documents up-to-date. These documents are.

- 1.-The Specifications,
- 2.-The Test plan with test spec,
- 3.-The project plan.

And have the main responsibility to make sure all other documents are up to date.

This role has the final say, in case of a dis-agreement. But the group leader cannot take or make a decision without first discussing the problem with the group.

The group leader has the right to sigh for the group, but not for the group members. But have to agree with the group before doing so.

Working hours

The main bulk of the work hours should be within normal working hours, 0900-1500.

The total scope of working hours should be more than 500 h for the whole project. This implies roughly 150 h a moth, a man.

Working hours and load can be adjusted if the members agree.

It is expected that the efficiency of the hours should be 90%, this meant that there should be a correlation between hours booked and work finished.

If one member don not do their sheer of the work load, this member risks exclusion from the group. This has to be decided by the Internal Veileder or other relevant persons from HBV.

The group members are required to have a positive and proactive approach to the project

DRESSER RAND EXHAUST CASE STUDY

2.4 Project engineer by David Lybek

Has the responsibility, to do the required tasks that are demanded from the project at all times.

Have a clear responsibility to communicate when he / she thinks the project is lagging behind in any aspect

Have a responsibility to do the tasks that the project leader requires if these are within the scope of the project, but also have the responsibility to raise concerns about the project leaders actions when he / she finds it appropriate.

For working hours see group leader.

DRESSER RAND EXHAUST CASE STUDY

3 THE PROJECT GOAL

3.1 The Problem

In the past Dresser Rand have had problem, winning contracts inside the Russian market, this is mostly due to the build space required for train transport, the driver enclosure is just too big to be transported by train to site.

In addition to this, there are challenges with maintenance and heat load in the exhaust case material, which could lead to cracks over time.

To fix these problems Dresser Rand sees a concept with an integrated enclosure and exhaust case, outside a shorter modified enclosure, and of a cold casing type.

For the project group to solve these problems we assume we need to build a 3d model of the new concept, integrating all the requirements from Dresser-Rand

3.2 Research question

The thesis problem is:

To implement all the required specifications from Dresser- Rand in to a exhaust case system 3d model, outside the turbine enclosure and of cold casing design.

3.2.1 Definitions

Implement

Is to include the requirement in to the model in a way that it is functional

Enclosure

Enclosed room for gas turbine, power turbine, gas generator and equipment.

System

All the components with inputs and outputs, of the exhaust case.

PT

Short for Power turbine, and is the part that makes the mechanical power out of the gas generator exhaust.

Gas generator or GG for short.

Is the engine that produces the exhaust gasses.

Exhaust case.

The mechanical part that takes the PT exhausts gasses and lead them out of the enclosure envelope.

DRESSER RAND EXHAUST CASE STUDY

DR
Short for Dresser-Rand Kongsberg AS

DRESSER RAND EXHAUST CASE STUDY

3.3 Limitation on work and scope

We will concentrate our work, on the exhaust case 3d-model, and not consider detailed drawings for this project. If there is time later in the project, this could be one of the tasks to focus on.

Note / info:

Detailed drawings are based on the 3d model and are roughly half the job, in finishing a production ready part. After drawings are finished the exhaust case drawing could be sent to sub suppliers for pricing.

We are limited to use NX7,5 for the 3d model design, this could affect the software availability for the project team.

We will not do any CFD work on the exhaust case, this is outside our capacity in respect to knowledge and time.

We will do the project based on a Vectra 40G power turbine.
Other turbines to consider in a later project are:

Vectra 30G
LM2000
LM2500
LM2500+G4

The exhaust case design will be based on a torque tube design, frame skid are to be considered later.

We will use the GANTT PROJECT software for project planning and resource allocation.

We may not meet as a group every day to discuss project matters.

We shall not look in to the enclosure redesign of the system.
Just suggest a simple interface between exhaust case and enclosure.
These matters are to be solved internally later by DR.

3.4 Assumptions

The project group needs access to the relevant data tools.

To effectively do the tasks at hand for this project, it is expected from each group member, to have a functional PC, a working internet line at home and normal Office package from Microsoft.
Accepted format for documents are .PDF .DOC .DOCX .XLS or .XLSX.

The project group needs access to the applicable design tools.

To organize the model and to keep track of the modeling the project needs access to PLM software Teamcenter.

DRESSER RAND EXHAUST CASE STUDY

To do the actual 3d modeling the group needs access to NX-7.5 with integration to Teamcenter.
This must be provided by DR

DR needs to accept the spec and its requirements for the project to go forward

DR will have to give the group enough information to complete the project.
It is assumed that DR will give the group enough information and support so they can complete the project as intended.

The group assumes that all the members are qualified to do this project.

3.5 System evaluation

The degree of successes for the group in the project is dependent on:

How good we fulfilled the requirements in the specification.

Ingenuity or how innovative it is.

It is up to DR and HBV to weight and evaluate the success of the design.

3.6 Goals

3.6.1 Results for student

A BSc thesis that document how the group has planned to solve the problem.
A 3d model incorporating as many requirements as possible from DR

3.6.2 Effects for student

On the subject the student's shall generally expand their knowledge of turbine driven packages, and especially the exhaust system of these packages.
This should make them understand and recognize most of the complicated requirements of a turbine package exhaust case system, and how to use engineering methods and thinking to solve these.

In addition the student should gain experience in project work both practical and theoretical.

The group member should also learn and gain experience in rational problem solving.

These learning targets are described in more detail in
See *Appendix 3 Emnebeskrivelse*

DRESSER RAND EXHAUST CASE STUDY

3.6.3 Results for DR

A 3d model of a cold casing design exhaust case.

They should be able to offer a new concept in package design.

And a 3d model to show possible clients.

3.6.4 Effects for DR

They should be able to offer an exhaust case that can be transported in to the Russian market by train.

3.7 Challenges

One of the main challenges is to control the relative movement between exhaust collector and power turbine

One other challenge is to have control over temperature gradients in the exhaust case material, in most cases this means to have as little temperature difference in the material as possible.

This is a bigger problem during start-up then shut down.

And can also be a problem when the turbine is running at steady state load.

DRESSER RAND EXHAUST CASE STUDY

4 PROJECT MODEL

Evaluating the different project models

The choice of which project model to use, to organize this project is of great importance.

Choosing the wrong model could make you lose money, time, resources and market possibilities, and you will likely spend more time reaching the end result than is needed.

First we need to define some project assumptions.

The need for the system is known.

–DR need it to get access to the Russian market where train transport is essential, to reach and install the packages.

The concept is known.

-DR knows that this concept should work if implemented correctly. We do not have any reason to doubt this.

Requirement is known.

–DR and project group have developed the specification. And the project group does not know of any requirement that they don't know of when the project is started.

The project group does not know how the requirements will affect the final design in detail. But they are certain that it will be necessary to do revisions/ iterations of the spec. to fulfill the functional purpose of the system, in a satisfactory way.

4.1 Sequential models

4.1.1 Water fall model

This is the classical project model where every step is sequential.

This means that we are not allowed to move forward before the current task/ activity is done, and in absolute order.

This is a very risky model because, if there has been done some error or there is a change in an earlier activity/ step, all the activities from that activity have to be done again all over again.

It is a very rigid project model, that is not very well suited for changes, on system or process.

It is very time consuming to plan, because you have to know every step in advance.

This model will maximize risk of not completing the project, in that sense that it could make the project stop up, for some time if we meet on trouble.

DRESSER RAND EXHAUST CASE STUDY

The big advantage with this model is that the project should be very confident and have a good understanding of the current situation before we move to the next step.

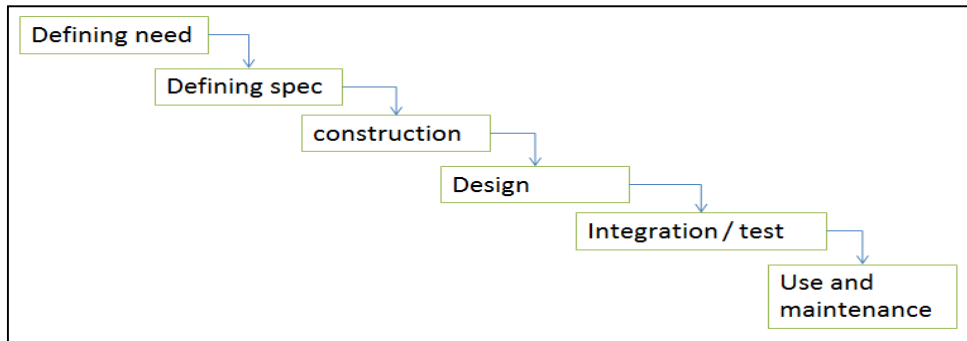

Fig 02

4.2 Evolutionary project models

In contradiction to a sequential project models, evolutionary model does go back to earlier steps in the project.

To perform a check or update of the earlier performed tasks to see if the “knowledge gained” or “change in circumstances” could influence earlier or future decisions.

4.2.1 Incremental model

This is a model where the spec is known and there should not be any surprises implementing the requirement in the system. This approach groups the requirements in logical groups and the incremental loop usual consists of something like construction, realization and test. This loop will be redone several times until all the requirements are implemented in the system, building on top of the last development loop.

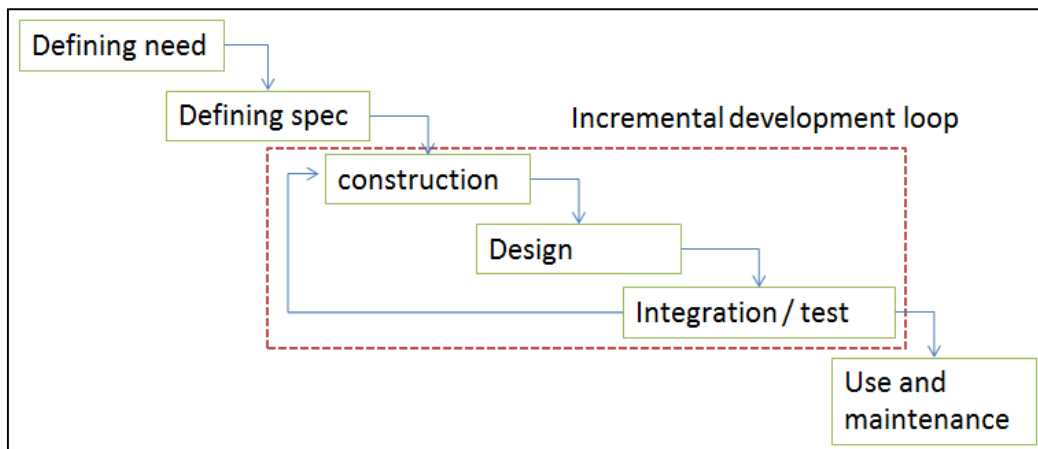

Fig 03

DRESSER RAND EXHAUST CASE STUDY

Another evolutionary model is the prototype approach.

In this project model we are not certain on the final spec before starting with the construction phase, we actually expect the spec to change. So the incremental development loop will also include the defining of spec.

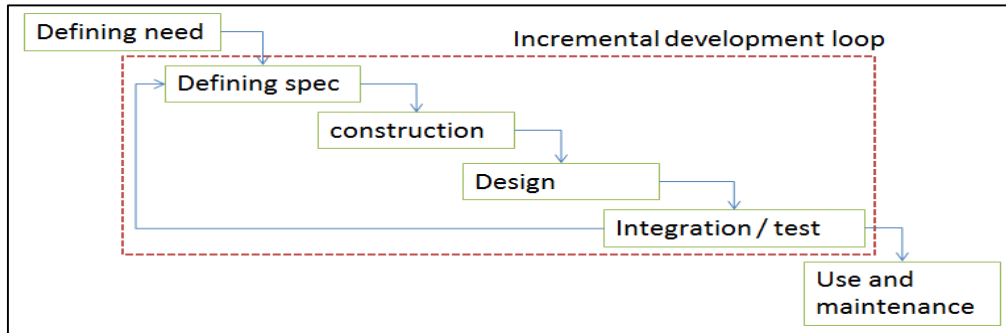

Fig 04 prototyping project model

Both the incremental and prototyping models are very close to our needs and could be used in our project. But we have to consider that the idea, concept and spec are known and that the unknown is the implementation and detailing of the requirement. This could suit the incremental development loop quite good, but we are quite certain the spec will change some, during the project.

Taking this in to the consideration we should also look to the prototype model. What we have chosen to do is a mix between the incremental and prototype model.

Since we are open to change in the spec during the project we have to plan for this.

What we want to do, is as long as the integration/ test are approved, we will continue to use an incremental approach to the project. But in the case there is a problem during the test phase and we do not get the applicable test approved, we will switch over to a prototype mode.

In this we believe we can maintain some of the flexibility of the prototype model and the effectiveness and risk reducing properties of the incremental model.

We will also plan for at least one revision of all the main documents, so we can pick up any / some of the uncertainties with the project.

This will lead to a project model that looks something like this.

DRESSER RAND EXHAUST CASE STUDY

4.3 Our hybrid project model.

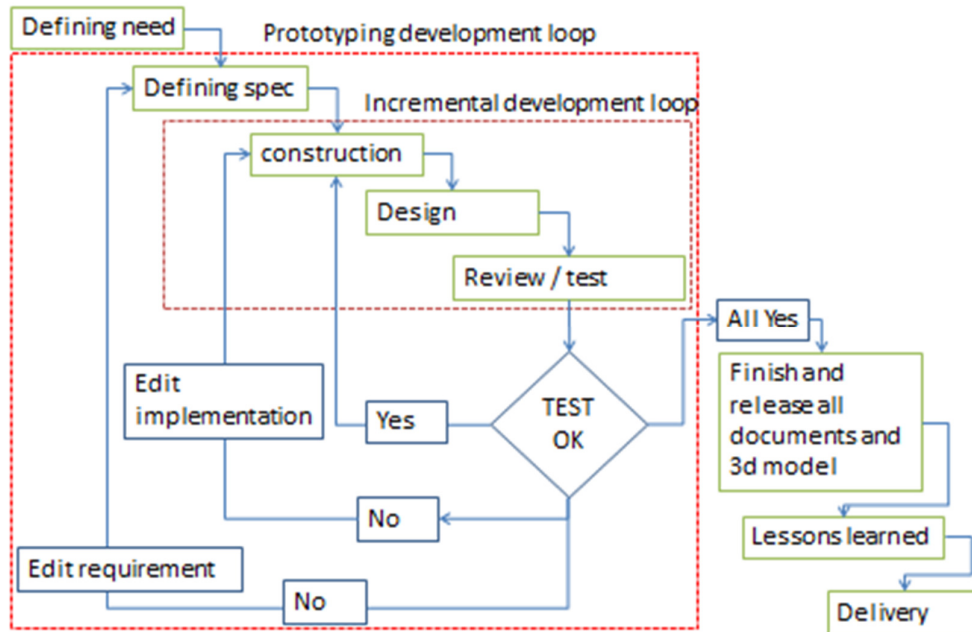

Fig 05

Hybrid project model

After feedback and thinking about the type of problems in our project, we see a project where we plan for several logical reviews / tests to fulfill all the requirements.

This we think this could be a manageable, effective, incremental and risk reducing approach to the project.

This will result in several “incremental development loops” as seen in fig 05 above.

But this approach alone is not enough to ensure the quality of the project. Since the spec is open and we believe it to change, we need a system to handle this.

This will be handled in 4 different ways.

1. - After each Integration/ test there should be done an analyses, that looks at current development, the past and the way forward to asses if there is a need to change the spec. This task is not shoved in the fig above but is in the planned for in the GANT chart.
2. - If the result from one integration / test is NO, there have to be done an analysis of the spec to see how this should change.
3. - Half way in the project there is a mandatory revision of Spec and all other relevant document.

DRESSER RAND EXHAUST CASE STUDY

4. - After finishing the last test there should be done an after analyses to see what could be done differently.

Whit this model we believe that we could execute the project in an effective manner and also maintain the flexibility we think we need.

4.4 Concerns

One big conserve I have with this approach is the work required to follow up the project and progress.

There could be many incremental loops and the inputs and outputs to each of these loops could amount to a lot of documentation work.

DRESSER RAND EXHAUST CASE STUDY

5 PROJECT STAGES AND ACTIVITY BREAK DOWN

All projects can be divided in to what we can call stages and activity's a stage of a project could contain many different activity's.

For our project there will be 3 main stages, these are:

- 1 Project scope development
2. Engineering
3. Delivery and lessons learned

The group could add more stages and activities into the project. But since we are only 2 persons, and since there is always a documentation job associated to every stage and activity. We want to keep the number of stages and activities low, to secure good progress.

Project scope development

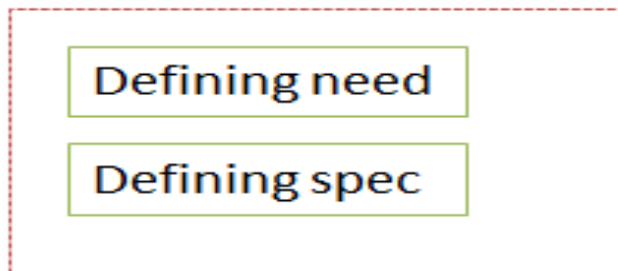

Fig 06

5.1 Defining need

In this stage the main focus is to clarify the scope of the development that should take place in the project

There should always be a “need” for something that is not available, if not then there is no need for a project.

The “need” could come from anyone, an organization, a person, a marked or from the developer.

It is “need” that, we, as a project-group need to define, and clarify with the ones expressing the need.

In our case DR is the one expressing their “need” for a new exhaust case.

The group has to investigate what DR really wants and how we can fulfill this need with the available resources.

DRESSER RAND EXHAUST CASE STUDY

In our case the result of this stage should be at least 3 documents.

- 1.-Specification
- 2.-Test specification
- 3.-Test plan

Figure below showing typical document output of different activities.

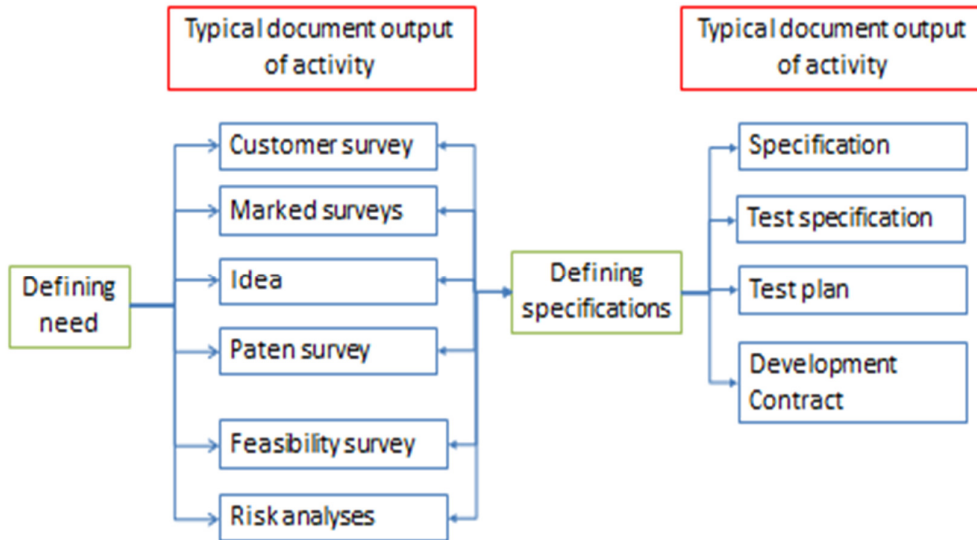

Fig 07 project scope development stage and typical document output

5.2 Engineering

Next stage is the engineering stage, where the group is focusing on the engineering / development work.

Engineering

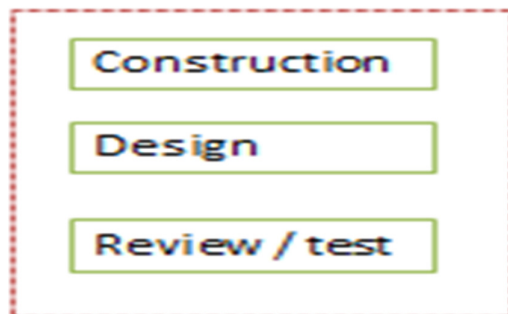

Fig 08 showing engineering stage activities

Typically the construction will result in some document output described in the figure below.

DRESSER RAND EXHAUST CASE STUDY

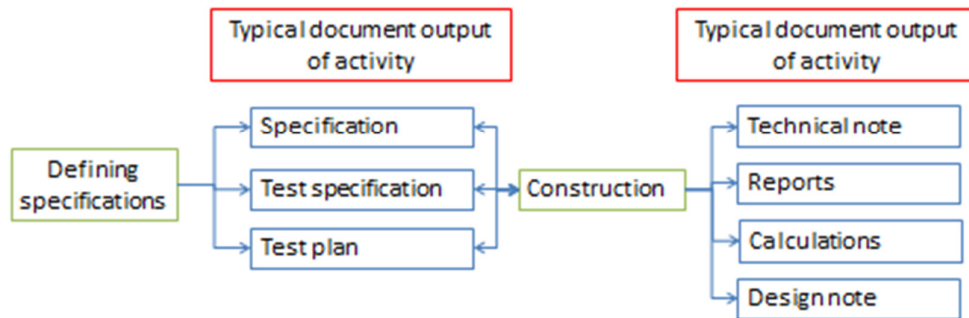

Fig 09 typical document output of construction activity

In our case the most probable document output of construction are design note, MOM preparation and calculations.

5.3 Design

The findings in the construction activity will help us implement the specification in to the NX 3d model

The design activity is basically to implement the specifications and findings in the construction activity in to the 3d model.

A typical output of this activity in our case is a 3d model, but it could also be a change request of some former documents or reports. As showed in the figure below.

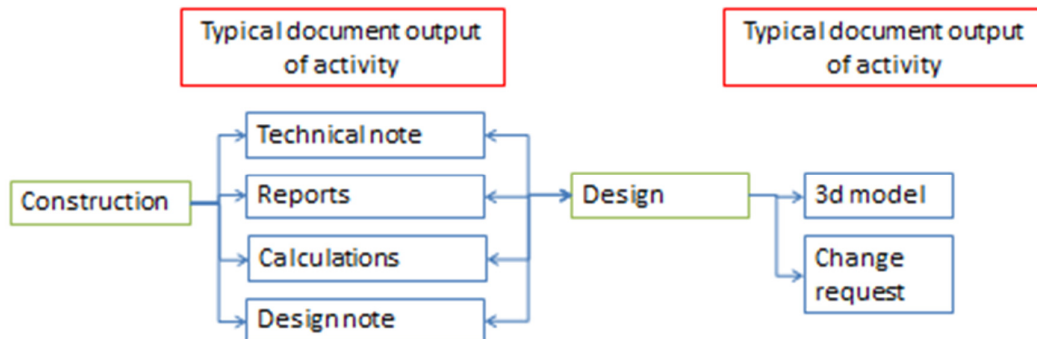

Fig 10 showing typical document flow for the design activity

5.4 Review and test

When the 3d model has all the requirements that are selected in the test plan implemented, it is ready for test.

In our case the test will consist of a review described in the test spec and test plan.

If all the reviews go without comment, or need to revise earlier documents, all of the DR requirement should be implemented, and the engineering stage should be mainly finished.

DRESSER RAND EXHAUST CASE STUDY

5.5 Delivery and lessons learned

Usually in regular project planning the lessons learned are done after delivery, with or without the customer but in this case since it is a BSc project and have learning and experience goal described in *Appendix 3 Emnebeskrivelse*.

The lessons learned are taken before delivery to show HBV that we have gained knowledge and experience according to the intentions.

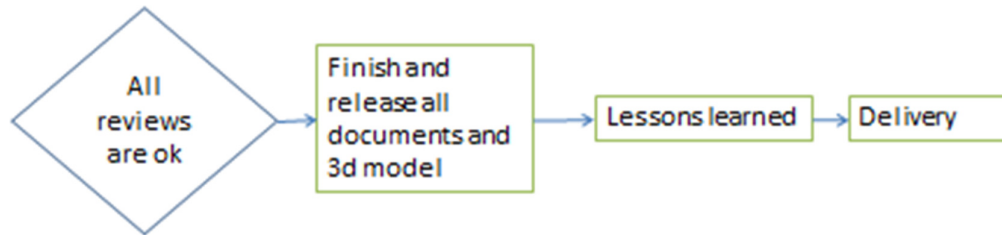

Fig 11 showing delivery and lessons learned stage in project

The delivery I out case is 2 folded, one for HBV and one for DR.

Delivery to HBV is described in detail in *Appendix 4 Innlevering+hovedprosjekt+2014.pdf*

5.6 Tasks.

This is the breakdown and numbering of the different tasks, so it possible to identify the tasks in the GANT diagram used to organize and monitor progress. See *Appendix 5*

The task numbers should also be possible to find in the timesheets reported every week.

There they are tagged with the task type number and a test number.
An example would be Test 2 / 1003 Construction

1000- Defining need

Here are the activity's to start and initiate the project

1001- Specification

This is the activity were we work on the requirements for the exhaust system.

1002- Planning

This is the activity were we specify what we think we will use of time on all the other tasks and activity's in the project.

1003- Construction

DRESSER RAND EXHAUST CASE STUDY

This is the activity where we investigate what and how we are going to implement the requirement from the spec. in to the exhaust collector system.
A lot of this will be hand calculations and studying of existing data.

1004- Realization / modeling

This is the activity where we implement the findings in our construction phase.

1005- Review

This is the activity where we show our work to other than ourselves.
Usually there are internal reviews where just the project group are involved, and external reviews where the client or third party is attending.

1006- Release.

Closing of the MOM from the test or closing of any other actions that the review revealed

1007- Analyses.

The activities where we try to break down data in to understandable pieces, so we can act in a rational way to the data and/ or problem we face or want to solve

1008- Milestones

Milestones are not a activity but a virtual "line" we have to cross. How we cross this "line is dependent on how good we have prepared for the crossing.

1009- Project management

This is the activity where we try to take back control over the hours spent on other things than this project.

1010- Other

For non-specified task, and to put slack in to the project plan.

1011- Lesson learned

This is where we sum up and see what was good and what was not good, to understand and learn from it.

1012- Delivery

Everything that has to do with finishing and delivering the project.

DRESSER RAND EXHAUST CASE STUDY

Appendix A: References

The following table summarizes the documents referenced in this document.

Document Name and Version	Description	Location
1.-Contractt 2014-vedlegg 1	Contractt	This document and folder
2.-Resources table	Table of resources	This document
3.-Emne beskrivelse	Doc	Fra HBV
4.-inlevering av hovedprosjekt	..pdf file	Fra HBV
5.-GANT	Gant diagram	Vedlegg

DRESSER RAND EXHAUST CASE STUDY

1 Appendix 1



**STANDARDAVTALE FOR STUDENTENES ARBEID MED
BACHELOROPPGAVEN MED EKSTERNE OPPDRAGSGIVERE
VED HØGSKOLEN I BUSKERUD OG VESTFOLD – FAKULTET
FOR TEKNOLOGI OG MARITIME FAG – KONGSBERG
INSTITUTT FOR INGENIØRFAG.**

**Høgskolen i Buskerud og Vestfold
Fakultet for Teknologi og Maritime fag
Kongsberg Institutt for Ingeniørfag**

DRESSER RAND EXHAUST CASE STUDY

1. BAKGRUNN

Formålet med denne kontrakten er å formalisere forholdet mellom ekstern oppdragsgiver, Høgskolen i Buskerud og Vestfold og studentene i arbeidet med hovedprosjektet for avgangstudentene ved Avdeling for Teknologi og Maritime fag – Kongsberg Institutt for Ingeniørfag ved Høgskolen i Buskerud.

Denne avtale definerer plikter og rettigheter for partene i forbindelse med dette arbeidet.

Oppdragsgiver er kjent med og aksepterer fullt ut at dette arbeidet er utført som et ledd i en høyskoleingeniørutdanning og at Høgskolen i Buskerud og Vestfold ikke kan garantere for arbeidets kvalitet eller påta seg noe økonomisk eller juridisk ansvar for det produktet som arbeidet fører til, eller bruken av produktet i noen sammenheng. Høgskolen kan heller ikke påta seg vedlikeholdsansvar for det produktet som utvikles i forbindelse med hovedprosjektet.

Studentene har ikke anledning til å motta lønn for arbeidet som utføres.

2. PARTER

Avtalen har tre parter:

- Avgangsstudentene i prosjektgruppen, nedenfor kalt Studentene.
- Ekstern oppdragsgiver, Firma Dresser Rand AS nedenfor kalt oppdragsgiver.
- Høgskolen i Buskerud, nedenfor kalt Høgskolen.

3. OPPDRAGSGIVERS PLIKTER

Oppdragsgiver skal oppnevne en av sine ansatte som ekstern veileder for studentene. Det forutsettes at veilederen gir studentene den nødvendige hjelp med å definere oppgaven samt skaffe nødvendig underlag for arbeidet og at veilederen har myndighet til å opptre som ansvarlig representant for oppdragsgiver i spørsmål som omfattes av denne kontrakten.

Under arbeidet er det viktig at studentene får god anledning til regelmessige samtaler med veilederen i prosjektperioden.

Videre kreves det at oppdragsgiver stiller kvalifisert ekstern sensor (mastergrad / siv.ing eller tilsvarende innen fagområdet) til rådighet for prosjektet. Ekstern sensor skal medvirke ved evaluering av prosjektarbeidet. Ekstern sensor kan være den samme som veilederen.

Den eksterne veilederen skal godkjenne alle studentenes rapporter.

4. OPPDRAGSGIVERS RETTIGHETER

Oppdragsgiver har fulle rettigheter til å benytte resultatet av hovedprosjektet med mindre noe annet er angitt i vedlegget til denne kontrakten.

Ved bruk og eventuell publisering av resultatene av oppgaven skal det henvises til at arbeidet er et studentarbeid ved Høgskolen i Buskerud, Avdeling for Teknologi samt studentenes og veiledernes navn.

Oppdragsgiver skal lese og godkjenne alle rapporter før publisering, og forbeholder seg retten til og undra hele eller deler av materialet fra offentligheten.

DRESSER RAND EXHAUST CASE STUDY

5. HØGSKOLENS PLIKTER

Ved starten av avgangsåret skal studentene deles opp i prosjektgrupper på 4-6 personer som sammen skal gjennomføre en større oppgave, et hovedprosjekt. Omfanget er 20 studiepoeng. Dette tilsvarer ca. 600 timers arbeid pr. student.

Før arbeidet med hovedprosjektet tar til skal studentene ha gått gjennom faget prosjektstyring. De skal videre ha organisert seg i prosjektgrupper og innhentet en egnet prosjektoppgave fra oppdragsgiver. I faget systemarbeid og prosjektstyring vil de bli bedt om å utføre en forstudie, en kravspesifikasjon og en prosjektplan i forbindelse med den foreslåtte prosjektoppgaven og rapportere disse fasene skriftlig.

Hovedprosjektet skal evalueres med vanlige karakterer. Evalueringen vil bli gjort på grunnlag av det utførte arbeidet og av en rekke dokumenter og muntlige fremføringer/utspørringer samt regelmessige møter. Karakterene settes på individuelt grunnlag av intern veileder, intern sensor og ekstern sensor.

Høgskolen stiller intern veileder og intern sensor til rådighet i forbindelse med dette arbeidet.

6. HØGSKOLENS RETTIGHETER

Høgskolen har rett til vederlagsfritt å benytte resultatet av oppgaven i sin undervisning med mindre noe annet er angitt i vedlegget til denne kontrakten. Dette forutsetter at informasjonen som brukes er lest og godkjent for publisering av DR.

DRESSER RAND EXHAUST CASE STUDY

7. UTGIFTER

Det vil påløpe en del utgifter i forbindelse med arbeidet. Disse dekkes på følgende måte:

Lønn	Studentene skal ikke motta lønn for arbeidet med hovedoppgaven. Den eksterne veilederens og sensors lønn og utgifter dekkes fullt ut av oppdragsgiver. Den interne veilederens og sensors lønn og utgifter dekkes fullt ut av høgsolen.
Innkjøp av utstyr	Innkjøp av utstyr og bøker skal ordnes via oppdragsgiver. Innkjøp utstyr og bøker er oppdragsgiver sin eiendom etter prosjektperioden.
Andre utgifter inkludert reiser	Oppdragsgiver dekker studentenes direkte utgifter. Alle utgifter skal avtales og godkjennes på forhånd av oppdragsgiver.

8. UTSTYR OG KOMPONENTER

Høgsolen stiller sitt utstyr vederlagsfritt til disposisjon for studentene i den grad utstyret er egnet og tilgjengelig.

Utstyr som lånes ut fra oppdragsgiver skal fortrinnsvis monteres i høgsolens lokaler. Utstyret skal holdes forsikret av oppdragsgiver. Utgifter til vedlikehold av utstyret dekkes av oppdragsgiver.

Komponenter til utstyr som konstrueres og bygges under arbeidet med hovedprosjektet betales av oppdragsgiver.

Utlånt utstyr og innkjøpte komponenter skal dokumenteres i eget vedlegg.

DRESSER RAND EXHAUST CASE STUDY

9. ENDRINGER

Alle endringer på denne standardavtalen skal dokumenteres i eget vedlegg.

10. VEDLEGGSLISTE

1. Endringer av standardavtale.
2. Utlånt utstyr og innkjøpte komponenter.

Dato:

For Oppdragsgiver

For Høgskolen

Øivind Eidsmoen

Studentene:

David Lybek, Godwin Narnor

DRESSER RAND EXHAUST CASE STUDY

Vedlegg1

Endringer

Kap 2.-
Dresser Rand AS

Kap 4.-
Oppdragsgiver skal lese og godkjenne alle rapporter før publisering, og forbeholder seg retten til og undra hele eller deler av materialet fra offentligheten.

Kap 6.-
Detter forutsetter at informasjonen som bruker er lest og godkjent for publisering av DR.

DRESSER RAND EXHAUST CASE STUDY

Vedlegg 2

Utlånt utstyr

Intet utstyr utlånt ved kontrakts inngåelse

DRESSER RAND EXHAUST CASE STUDY

Appendix 2

Position	Rolls	Main tasks
Manager / technical lead <i>Øivind Eidsmoen</i>	Oversight Approval Technical responsible	Final approval Attend reviews Approve reviews
Technical support <i>Svein Y Jakobsen</i>	Revision Resource manager	Technical support Technical advise Attend reviews Approve review
Project engineer <i>David Lybek</i> <i>Godwin Narnor</i>	Technical engineer Group leader	Write thesis Engineer Solve the task Writhe report Write MOM Write required document
Exhaust case experts <i>Torun Jensen</i> <i>Thuy Vu Vuong</i>	Expert advise	Support in reviews Technical support in general
Engineering Support <i>Engineering department</i>	Engineering support	Support in reviews Technical support in general

DRESSER RAND EXHAUST CASE STUDY

Appendix 3

SFHO-3201	Bacheloroppgave	20 Studiepoeng
Norsk, engelsk ved behov	Bachelor i ingeniørfag, alle retninger	VAR

1. LÆRINGSUTBYTTE

Studenten skal *ha kunnskap om og demonstrere* ferdigheter i grunnleggende prosjektarbeid og hvordan dette organiseres og dokumenteres.

Studenten skal *ha kunnskap om vitenskapelige metoder og vitenskapsteori*.

Studenten skal *gjennomføre* og demonstrere samarbeide med andre om et større stykke ingeniørarbeide i prosjektgrupper.

Studenten skal *demonstrere* praktisk planlegging, gjennomføring og dokumentering av et utviklingsprosjekt.

Studenten skal kunne organisere, velge og utnytte relevant verktøy, utøve lederskap, håndtere kommunikasjon samt planlegge og gjennomføre nødvendig testing underveis og i slutfasen.

2. INNHOLD

Emnet inneholder en innføring i praktisk planlegging og gjennomføring av et utviklingsprosjekt. Det legges vekt på prosjektarbeidsformen og de teknikkene som denne benytter seg av. Det legges opp til å bruke moderne verktøy i arbeidet. Prosjektarbeidet kan inneholde elementer fra samtlige tekniske og økonomiske fag i utdanningen. Oppgavene hentes fra næringslivet, men kan også hentes fra egne ideer.

Studentene skal gjennomføre en mest mulig realistisk trening i å gjennomføre en større arbeidsoppgave organisert som prosjektarbeid helt fra problemdefinisjon via kravspesifikasjon til ferdig system/produkt.

3. LÆRINGSAKTIVITETER

Undervisningsopplegget inneholder forelesninger i forbindelse med prosjektstyringsdelen.

Forøvrig arbeides det i grupper med praktisk prosjektarbeid, inkludert veiledning fra høgskole og oppdragsgiver. Gruppene består av 4-6 studenter, og settes sammen av avdelingen etter forslag fra studentene.

4. FORKUNNSKAPSKRAV

Det forutsettes at alle emner i 1. og 2. årskurs er gjennomført.

5. DELTAGELSE

Av hver enkelt kreves det deltagelse i gruppens faglige aktiviteter og deltagelse i møter med høgskole og oppdragsgiver. Det er et krav at studenten møter og gjennomfører oppgavene gruppen er pålagt i forbindelse med vurderingene.

6. VURDERING

Elementer i vurderingen er todelt:

■ Gruppe del:

Dokumentasjon

1. Form
2. Kompletthet
3. Lesbarhet

Prosjekt presentasjoner

1. Fremføring
2. Klarhet
3. Kompletthet

Produkt

1. Effektivitet
2. Vedlikeholdbarhet
3. Utvidbarhet

DRESSER RAND EXHAUST CASE STUDY

4. Kostnad

Fremdrifts prosessen basert på :

1. Referater
2. Timelister
3. Internveileder sine notater
4. Gruppa sine oppfølgingsdokumenter (Skal finnes for hvert prosjektmøte)
5. Muntlige utspørringer.

■ Individuell del: justeringer av enkeltpersoner.

1. Kjennskap til eget ansvarsområde og det arbeidet som er utført
2. Generell kunnskap om prosjektet
3. Deltagelse i prosjektet

Generelt sett skal vektlegningen av total vurdering være slik:

¼ produktet

¼ presentasjonene

½ dokumentasjonen og prosessen som leder frem til denne

Alt sammen justert på bakgrunn av individuelt arbeid og resultatene av utspørringene.

Vurderingsuttrykk

Sluttkarakter gis individuelt til hver enkelt kandidat og angis som gradert bokstavkarakter F-A.

7. PENSUM

Forelesningsnotater legges ut på nett i forbindelse med forelesningene

8. ANNET

Veiledningen

Prosjektgruppen har to veiledere, en ekstern og en intern. Den interne veilederen er en faglig ansatt ved høgskolen. En ekstern veileder oppnevnes og betales av bedriftene.

Den interne veilederen vil følge opp arbeidet og bistå med råd og prinsipielle problemavklaringer slik at man får den nødvendige kontroll med framdriften. Hver gruppe har obligatoriske ukentlige prosjektmøter med intern veileder. Intern veileder vil være tilgjengelig til de tider som er avsatt til prosjektveiledning

Den eksterne veilederen utgjør den spesialtekniske kompetansen som prosjektgruppen støtter seg til. Prosjektmøter med ekstern veileder avtales med denne. Det lages skriftelig innkallinger og referater fra disse møtene. Møteledelse og sekretærfunksjonen går på rundgang mellom medlemmene av gruppa slik at alle får trening i disse aktivitetene.

Ingen av veilederne skal på noe tidspunkt forsøke å lede prosjektgruppas arbeid. Ledelse av gruppe er i første rekke gruppas kollektive ansvar, men der prosjektlederen har et ekstra ansvar.

Prosjektgruppas medlemmer fører ukentlige timelister der det fremgår hva som er gjort og hvor lang tid som er brukt. Dette sammenfattes og benyttes i fortløpende rapportering til de andre gruppedlemmene, veilederne og sensorene.

Sensorgruppe

Prosjektarbeidet sensureres av en sensorgruppe bestående av intern veileder, ekstern sensor og en hovedsensor oppnevnt av høgskolen. Hovedsensoren skal ha som oppgave å delta i sensureringen av alle årets prosjektoppgaver innen samme utdanning. Dette er viktig for å ivareta den relative evalueringen av alle prosjektene. Det kreves av oppdragsgiver for

DRESSER RAND EXHAUST CASE STUDY

prosjektgruppen at de stiller kvalifisert ekstern sensor til rådighet for prosjektet. Dette kan være den samme personen som er ekstern veileder.

GR 15 DRESSER RAND EXHAUST CASE STUDY
PRODUCT SPECIFICATION

Version 002

Author: David Lybek

25. May.2014

VERSION HISTORY

The first alpha and beta versions of this document will not be released to the customer.

After beta release the revisions are subjected to customer review.

The table below tracks the development of this document and the requirement of the exhaust collector design

Version #	Implemented By	Revision Date	Approved By	Approval Date	Reason
Alfa	DLY	09.feb.14	DLY	09.FEB.14	Initial draft
002	DLY	25.may.14	DLY	25.05.14	Release

Table of Contents

1 INTRODUCTION	4
1.1 Purpose of The Specification Document	4
2 BACKGROUND.....	4
2.1 Problem.....	4
2.2 Task	4
3 SYSTEM DESIGN.	5
3.1 Present design	5
3.2 New design	6
3.3 Performance	7
3.4 Requirements and new limitations	7
4 REQUIREMENTS	7
5 SPECIFICATION APPROVAL	8
6 APPENDIX A: REFERENCES	9
7 APPENDIX B: KEY TERMS	10
8 APPENDIX B: SPECIFICATION SPREAD SHEET PRINT / COPY	11

1 INTRODUCTION

1.1 PURPOSE OF THE SPECIFICATION DOCUMENT

The purpose of this document is to define the exhaust case requirements also known as the product spec.

2 BACKGROUND

2.1 PROBLEM

Dresser-Rands current package design has the exhaust collector located inside the acoustic enclosure. This causes the following problem areas:

- Overall transport dimensions exceed the limits for rails transport in countries with potentially large markets.
- Heat emitted into enclosure requires increased ventilation flow, difficult to meet in hot environments
- Access to the collector for inspection and especially for change out is very difficult
- Access for connection of oil piping, instrumentation and shaft coupling is restricted
- Relatively complicated design with one enclosure and a collector inside this.
 - DR has to make 2 parts for this assy.
 1. - Enclosure
 2. - Exhaust case inside the enclosure.

DR would like to merge these 2 parts in to one.

2.2 TASK

DR sees a conceptually new design with the exhaust collector located outside the turbine enclosure will solve some or all of these issues.

The Assignment is to design a new exhaust collector system that generally meets the following criteria/ ideas:

- Located outside the acoustic enclosure and may be on a separate frame.
- A design with integrated insulation and housing/casing suited for outdoor installation. This is generally referred to as a “cold casing” design.
- The geometry of the collector shall be maintained.
This mainly applies to the exhaust case interfaces and diffusor.
- Includes noise break out reduction and surface temperature requirements.
- Meets all DR and customer defined HSE requirements

3 SYSTEM DESIGN.

3.1 PRESENT DESIGN

Today the driver packages consist of:

Filter, plenum, enclosure, ventilation inlet, turbine, exhaust case, exhaust duct and ventilation outlet.

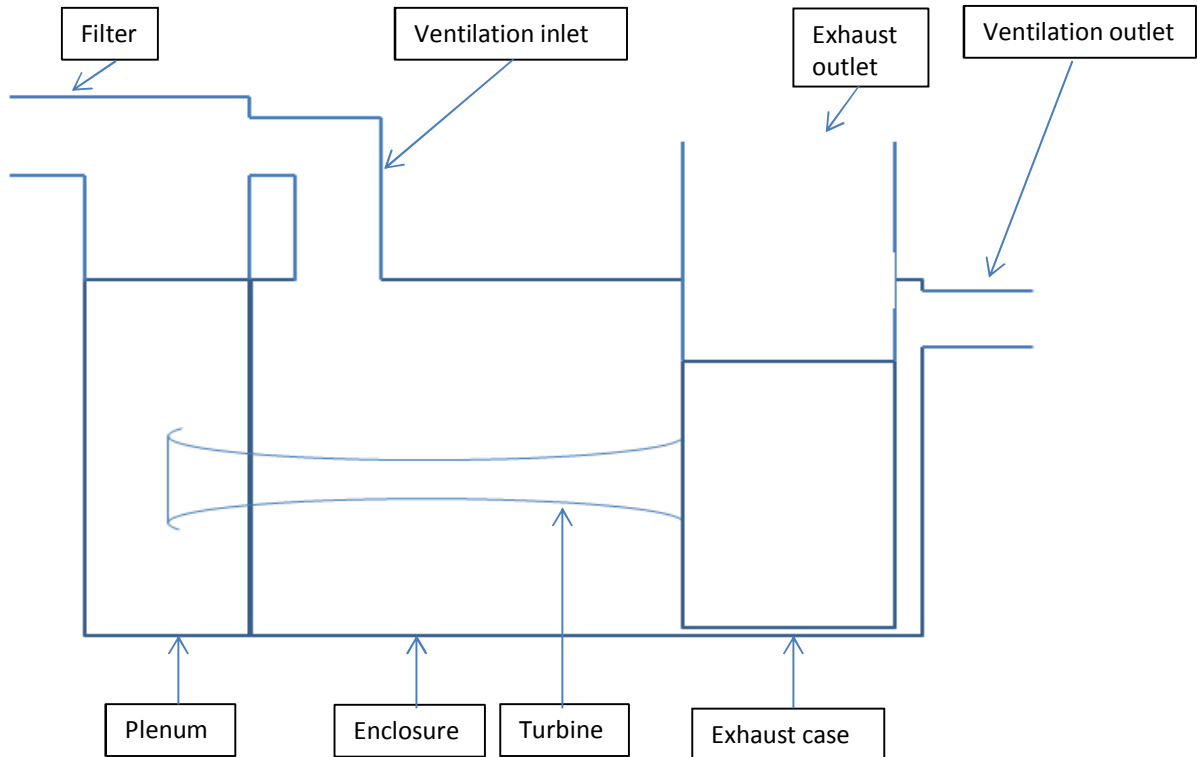

Figure 1 of today's system

3.2 NEW DESIGN

The new concept idea for the driver package looks like this:
Filter, plenum, enclosure, ventilation inlet, turbine, and ventilation outlet.
But there will be a separate removable exhaust enclosure.

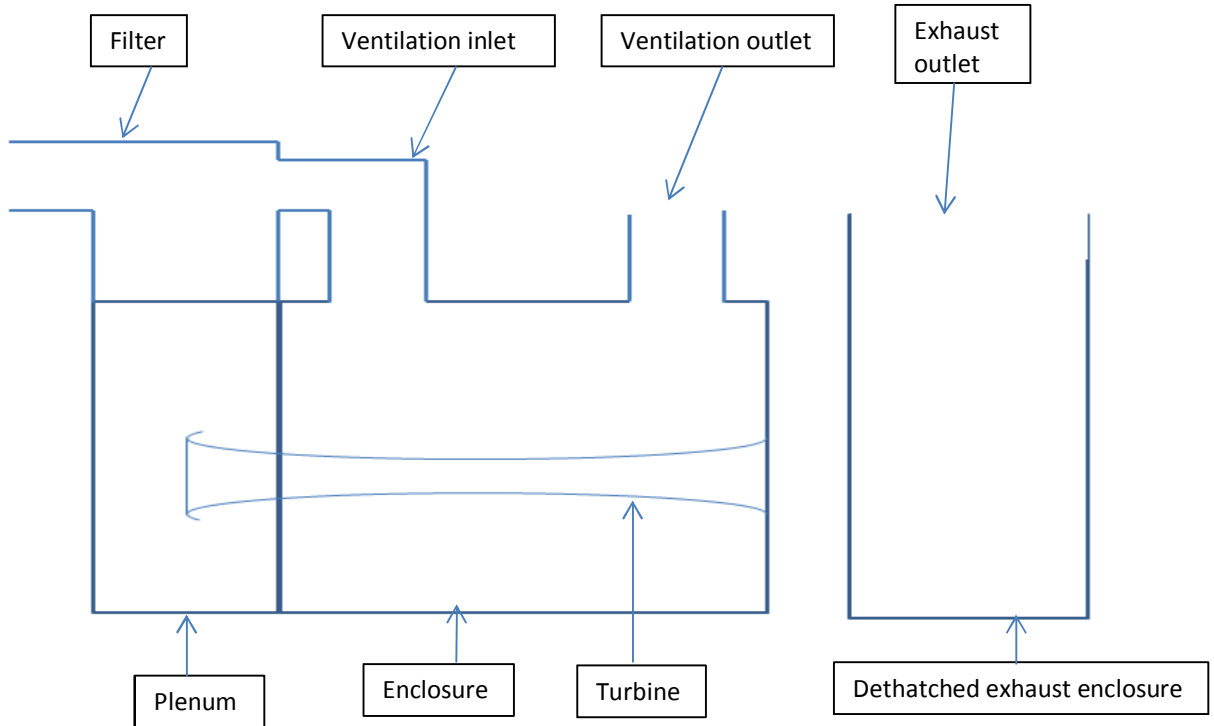

Fig 2 New driver concept with dethatched exhaust equipment.

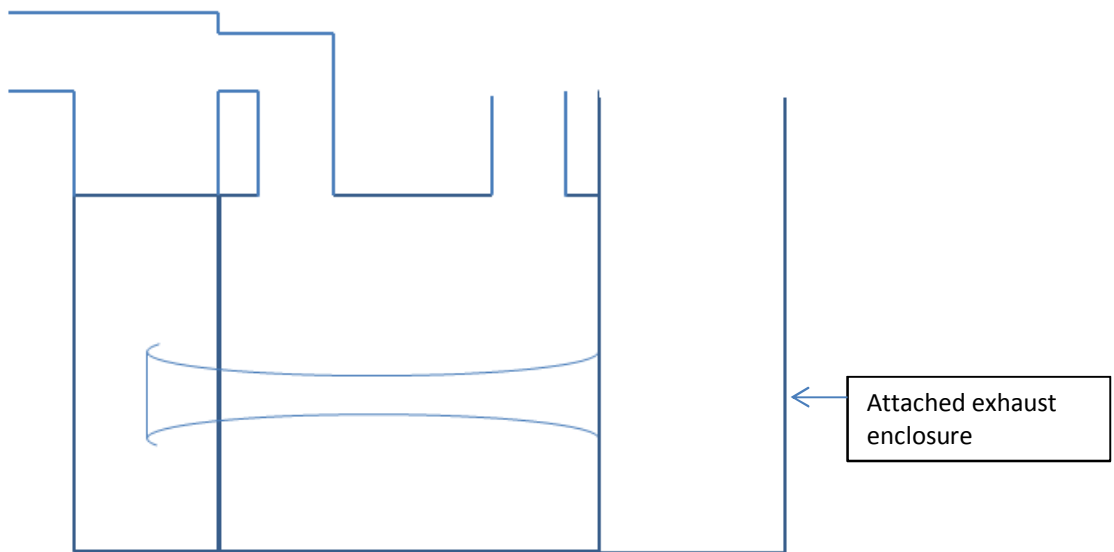

Fig 3 New driver concept with attached exhaust equipment

3.3 PERFORMANCE

The new system should not perform worse than today's exhaust system in regards to mechanical output. This will be achieved by using existing exhaust diffuser geometry.

3.4 REQUIREMENTS AND NEW LIMITATIONS

If there are requirements that show up during the study, that will severely limit the usage of the new exhaust system. These requirements have to be documented and communicated to DR a.s.a.p.

The implementation of these requirements will not be considered as a failure to deliver, and they should not stop the progress of the project.

If the limiting requirements are of a nature that will make the exhaust case unusable or unsalable, DR will have to be notified ASAP, so they can make the decision to stop the project or to change the project.

4 REQUIREMENTS

The requirements for the new exhaust case system are found in spreadsheet attachment 1 in this document.

Explanation of fields in attachment 1

NO: Fixed identifying number of each requirement

WHO: Who has come up with this requirement

WHEN: When was this requirement made

PRIME: Is this a primary requirement not dependent of other requirements

DEPENDENT: Indicate what requirement this is dependent on

DIFFICULTY: Expected difficulty of implementation

PRIORITY: How important is this requirement

ABSOLUT: This requirement is absolutely necessary

5 SPECIFICATION APPROVAL

This spec will have to be reviewed by the customer before release.

Any change in the spec will be subject to project review both internal and by customer.

To approve this spec the applicable spec will have to be signed by DR and GR 15

Signature: _____ Date: _____
Print Name: _____
Title: _____
Role: _____

Signature: _____ Date: _____
Print Name: _____
Title: _____
Role: _____

Signature: _____ Date: _____
Print Name: _____
Title: _____
Role: _____

6 APPENDIX A: REFERENCES

The following table summarizes the documents referenced in this document.

Document Name and Version	Description	Location
<i>Krav_002</i>	<i>Krav Exhaust case</i>	 krav_002.xlsx

7 APPENDIX B: KEY TERMS

The following table provides definitions for terms relevant to this document.

Term	Definition
<i>DR</i>	<i>Dresser Rand</i>
<i>Spec.</i>	<i>Specification</i>
<i>HSE</i>	<i>Health, Safety, Environment</i>
<i>Plenum</i>	<i>Air box before turbine</i>
<i>Enclosure</i>	<i>Enclosed room for turbine / equipment</i>
<i>Driver</i>	<i>Equipment providing the mechanical power</i>
<i>Package</i>	<i>The complete equipment providing the mechanical power</i>

8 APPENDIX B: SPECIFICATION SPREAD SHEET PRINT / COPY

REQ. NO.	REQ. DESCRIPTION	REQ. TYPE	REQ. STATUS	REQ. PRIORITY	REQ. ID	REQ. DESCRIPTION	TEST NO.	TEST DESCRIPTION	TEST METHOD	SUCCESS CRITERIA
1	DR-DE-14.1.2014	X	no	3	1	The design must have dimensions within the ball space defined by CR	Test 1	DR-provide data	Model review with DR	Model accepted
2	DR-DE-14.1.2014	X	no	1	1	The design must have dimensions within the vessel space defined by CR	Test 1	DR-provide data	Model review with DR	Model accepted
3	DR-DE-14.1.2014	X	no	2	1	The vessel number (T) be used for the vessel ID	Test 1	DR-provide data	Model review with DR	Model accepted
4	DR-DE-14.1.2014	X	no	1	1	The vessel number (T) be used for the vessel ID	Test 1	DR-provide data	Model review with DR	Model accepted
5	DR-DE-14.1.2014	X	no	1	1	The vessel number (T) be used for the vessel ID	Test 1	DR-provide data	Model review with DR	Model accepted
6	DR-DE-14.1.2014	X	no	1	1	The vessel number (T) be used for the vessel ID	Test 1	DR-provide data	Model review with DR	Model accepted
7	DR-DE-14.1.2014	X	no	2	1	The vessel number (T) be used for the vessel ID	Test 1	DR-provide data	Model review with DR	Model accepted
8	DR-DE-14.1.2014	X	no	1	1	The vessel number (T) be used for the vessel ID	Test 1	DR-provide data	Model review with DR	Model accepted
9	DR-DE-14.1.2014	X	no	1	1	The vessel number (T) be used for the vessel ID	Test 1	DR-provide data	Model review with DR	Model accepted
10	DR-DE-14.1.2014	X	no	1	2	The vessel number (T) be used for the vessel ID	Test 1	DR-provide data	Model review with DR	Model accepted
11	DR-DE-14.1.2014	X	no	3	3	The vessel number (T) be used for the vessel ID	Test 1	DR-provide data	Model review with DR	Model accepted
12	DR-DE-14.1.2014	X	no	2	3	The vessel number (T) be used for the vessel ID	Test 1	DR-provide data	Model review with DR	Model accepted
13	DR-DE-14.1.2014	X	no	1	3	The vessel number (T) be used for the vessel ID	Test 1	DR-provide data	Model review with DR	Model accepted
14	DR-DE-14.1.2014	X	no	1	3	The vessel number (T) be used for the vessel ID	Test 1	DR-provide data	Model review with DR	Model accepted
15	DR-DE-14.1.2014	X	no	2	1	The vessel number (T) be used for the vessel ID	Test 1	DR-provide data	Model review with DR	Model accepted
16	DR-DE-14.1.2014	X	no	3	1	The vessel number (T) be used for the vessel ID	Test 1	DR-provide data	Model review with DR	Model accepted
17	DR-DE-14.1.2014	X	no	1	1	The vessel number (T) be used for the vessel ID	Test 1	DR-provide data	Model review with DR	Model accepted
18	DR-DE-14.1.2014	X	no	3	3	The vessel number (T) be used for the vessel ID	Test 1	DR-provide data	Model review with DR	Model accepted
19	DR-DE-14.1.2014	X	no	1	1	The vessel number (T) be used for the vessel ID	Test 1	DR-provide data	Model review with DR	Model accepted
20	DR-DE-14.1.2014	X	no	3	3	The vessel number (T) be used for the vessel ID	Test 1	DR-provide data	Model review with DR	Model accepted
21	DR-DE-14.1.2014	X	no	2	1	The vessel number (T) be used for the vessel ID	Test 1	DR-provide data	Model review with DR	Model accepted
22	DR-DE-14.1.2014	X	no	2	2	The vessel number (T) be used for the vessel ID	Test 1	DR-provide data	Model review with DR	Model accepted
23	DR-DE-14.1.2014	X	no	1	1	The vessel number (T) be used for the vessel ID	Test 1	DR-provide data	Model review with DR	Model accepted
24	DR-DE-14.1.2014	X	no	1	1	The vessel number (T) be used for the vessel ID	Test 1	DR-provide data	Model review with DR	Model accepted
25	DR-DE-14.1.2014	X	no	1	1	The vessel number (T) be used for the vessel ID	Test 1	DR-provide data	Model review with DR	Model accepted
26	DR-DE-14.1.2014	X	no	1	2	The vessel number (T) be used for the vessel ID	Test 1	DR-provide data	Model review with DR	Model accepted
27	DR-DE-14.1.2014	X	no	1	1	The vessel number (T) be used for the vessel ID	Test 1	DR-provide data	Model review with DR	Model accepted
28	DR-DE-14.1.2014	X	no	2	1	The vessel number (T) be used for the vessel ID	Test 1	DR-provide data	Model review with DR	Model accepted
29	DR-DE-14.1.2014	X	no	2	1	The vessel number (T) be used for the vessel ID	Test 1	DR-provide data	Model review with DR	Model accepted
30	DR-DE-14.1.2014	X	no	2	1	The vessel number (T) be used for the vessel ID	Test 1	DR-provide data	Model review with DR	Model accepted
31	DR-DE-14.1.2014	X	no	2	1	The vessel number (T) be used for the vessel ID	Test 1	DR-provide data	Model review with DR	Model accepted
32	DR-DE-14.1.2014	X	no	2	1	The vessel number (T) be used for the vessel ID	Test 1	DR-provide data	Model review with DR	Model accepted
33	DR-DE-14.1.2014	X	no	2	1	The vessel number (T) be used for the vessel ID	Test 1	DR-provide data	Model review with DR	Model accepted
34	DR-DE-14.1.2014	X	no	2	1	The vessel number (T) be used for the vessel ID	Test 1	DR-provide data	Model review with DR	Model accepted
35	DR-DE-14.1.2014	X	no	2	1	The vessel number (T) be used for the vessel ID	Test 1	DR-provide data	Model review with DR	Model accepted

DRESSER RAND EXHAUST CASE STUDY

Appendix 4



INNLEVERING HOVEDPROSJEKT

FRIST: MANDAG 26 MAI 2014 KL 12.00 TIL BARBRØ

Innlevering av følgende deler: dokumentasjon, 5 x sensorark (inkluderer produktokumentasjonen for alle grupper og produktet hvis det er et virtuelt produkt)

FRIST: MANDAG 26 MAI 2014 KL 12.00 TIL BARBRØ

Innlevering av følgende deler: Sensorark – elektronisk via epost. (Hensikten er å registrere informasjon om prosjektet deres)

FRIST: MANDAG 2 JUNI 2014 KL 12.00 TIL BARBRØ

Siste frist for innlevering av fysisk plakat.

FRIST: PRESENTASJONSDAGEN TIL KAROLINE MOHOLTH

Innlevering av endelig cd/dvd x3

FREDAG 13 JUNI 2014 KL 10.00-12.15 – FØR UTDELING AV VITNEMÅL

I forbindelse med vitnemålutdelingen henger vi opp plakatene i glassgangen og gruppene skal være der og vise frem/fortelle om det de har gjort til foreldre og andre interesserte

I tillegg må prosjektets webside være oppdatert gjennom hele denne perioden

DOKUMENTASJON

Dokumentasjonen skal leves til høgskolen i tre (3) eksemplarer.

1. Det første eksemplaret er for arkivformål, og benyttes av intern sensor i forbindelse med sensur. Denne kopien skal leves i en perm med svart farge i 2014 og med prosjektets navn og nummer klart merket på ryggen. Denne permen skal inneholde en papirutskrift av all viktig dokumentasjon på papir samt en CD/DVD med alt produsert materiale i løpet av prosjektet, dokumentasjon, timelister, møteinnkallinger og referater samt kilde kode og tegninger. Denne CD/DVDen skal ligge i en plastlomme som sitter fast inne i permen.

2. Det andre eksemplaret er for fremtidig utlån, dette eksemplaret skal bindes inn slik at man ikke kan fjerne enkeltark og kan inneholde alt som er offentlig tilgjengelig. Oppgaven bindes inn med limt rygg hvis det er praktisk mulig. Dersom alt er tilgjengelig kan denne innbundelen versjonen inneholde det samme som den svarte permen, dersom f. eks

GR 15 DRESSER RAND EXHAUST CASE STUDY
TEST PLAN

Version 002

Author: David Lybek

14. May.2014

Contents

1	Summary.....	3
2	Key Terms	4
3	Document revision history	5
4	Introduction.....	6
5	Tests	7
5.1	Organization of tests.....	7
5.2	Test output.....	7
5.3	Acceptance of requirement	7
5.4	Resource availability	7
6	Appendix A: References	8
	Appendix B: Specification spread sheet copy.....	9

1 Summary

This plan is developed to describe how we are going to design a new exhaust system for DR. This system is of a cold casing design, and should be fully integrated with the package enclosure. The main task for the exhaust system is to vent exhaust gasses to a safe area, after they have been used to produce mechanical power in the power turbine. The exhaust case also has many other functions related to HSE that will need testing.

2 Key Terms

The following table provides definitions for terms relevant to this document.

Term	Definition
<i>DR</i>	<i>Dresser Rand</i>
<i>Spec.</i>	<i>Specification</i>
<i>HSE</i>	<i>Health, Safety, Environment</i>
<i>Plenum</i>	<i>Air box before turbine</i>
<i>Enclosure</i>	<i>Enclosed room for turbine / equipment</i>
<i>Driver</i>	<i>Equipment providing the mechanical power</i>
<i>Package</i>	<i>The complete equipment providing the mechanical power</i>

3 Document revision history

Version #	Implemented By	Revision Date	Approved By	Approval Date	Reason
001	<i>DLY</i>	<i>09.feb.14</i>	<i>DLY</i>	<i>09.FEB.14</i>	Initial release
002	DLY	14.may.14	DLY	14.may.14	release

4 Introduction

This document is made to describe how we are going to test the specifications for the exhaust case.

The final main output of this project would be detailed fabrication drawings of the exhaust case system with supporting documentation, but resource availability restricts this project capacity so we think the main output of this project will be a 3d- model of the exhaust case

The 3d models will be the main object to be tested in this project.

What you can do to a 3d-model is limited to “non-real” testing. (not testing a physical object)

This means we will not be able to test any physical product but instead we will test a computerized model of the exhaust case.

What you generate in the 3d-model can be used in many ways.

- 1.- Generate a 3d model of the actual part.
- 2.- Generate a printed version of the actual part.
- 3.- Generate an actual print of the actual part.
- 4.- Generate drawing of layouts
- 5.- Generate drawings of fabrication steps.
- 6.- Generate user manual documentation.
- 7.- Simulate maintenance procedures
- 8.- Simulate fabrication of the part.
- 9.- Simulate handling of the part.
- 10.- Simulate user cases.
- 11.- Calculate physical property's
- 12.- Simulate different scenarios of usage.
- 13.- Analyze physical behaviors
- 14.- Analyze mechanical behavior

This is just an example of what is possible to do with a good 3d-model and the right data tools.

5 Tests

In our case the testing will primary be model review done with DR, the 3d-model will also function as a premise provider for the calculations and analyses that might be done. The reviews will be based on this test plan.

5.1 Organization of tests

Each test has a unique number, example Test 0a, see attachment 1 for further detail. In the test plan al the requirement listed in the specification will be allocated to a specific test. All other requirement for the each test will be noted in detail in the attached test plan, including date, required resources, agenda, what to test, and expected output. We start with Test 1 then Test 2 etc.

5.2 Test output

The output of a review / test is typically a revision of the 3d-model, and a MOM with applicable actions to be taken on the requirement reviewed. In light of the low resources availability in the group we have to be very pragmatic and strict about time spent. In this respect it will be noted that some of the project documentation will have relative low formal quality and look, but we will try to be very focused on the engineering aspect of the problems and meaning of the documents.

5.3 Acceptance of requirement

A requirement is accepted as implemented in the system when the MOM is closed for that requirement. If there are requirement that have changed based on model review, The spec will have to be revised, and the new requirement to be closed in the same MOM, or to be implemented in a later test, or can in some cases be subjected to a separate test. Bases on the also revised test plan.

5.4 Resource availability

Because of time restrain test No 5, with its requirement are not done, They are instead handled in the Design notes.

6 Appendix A: References

The following table summarizes the documents referenced in this document.

Document Name and Version	Description	Location
<i>Test spec_001</i>	<i>XLXS file of the Test spec</i>	 test spec_001.xlsx

Appendix B: Specification spread sheet copy.

NOI TYPE	DATA REQUIRE DESCRIPTION	WHAT TO CONSIDER	DOCUMENT OR ACCEPTANCE OF	REVIEW COMMENTS	
Task 1 Append main form: 1- Set gear of model 2- Set main identifier	1	The set gear must have dimension within the built-in set of field by OR	DR to check if model (for which error report)	Clear/H001	
	2	The set gear must have dimension within the set gear by OR	DR to check if model (for which error report)	Clear/H001	
	3	The main identifier (P) must be set for the product code by OR	DR to check if model (for which error report)	Clear/H001	
	4	The set gear must be set for the product code by OR	DR to check if model (for which error report)	Clear/H001	
	20	The set gear must be set for the product code by OR	DR to check if model (for which error report)	Clear/H001	
Task 2 Append main form: in the case of vehicle	5	Vehicle, make or manufacturer of the vehicle must be handled in one of the model	DR to check if model	Clear/H001	
	6	Vehicle, make or manufacturer of the vehicle must be handled in one of the model	DR to check if model	Clear/H001	
	16	Vehicle, make or manufacturer of the vehicle must be handled in one of the model	DR to check if model	Clear/H001	
	18	The set gear must be set for the product code by OR	DR to check if model	Clear/H001	
	19	The set gear must be set for the product code by OR	DR to check if model	Clear/H001	
Task 3 Append main form: 1- Calculation of gear 2- For hazard 3- Balance environment	7	DR to check if model (for which error report)	DR to check if model	Clear/H001	
	8	DR to check if model (for which error report)	DR to check if model	Clear/H001	
	9	DR to check if model (for which error report)	DR to check if model	Clear/H001	
	10	DR to check if model (for which error report)	DR to check if model	Clear/H001	
	24	DR to check if model (for which error report)	DR to check if model	Clear/H001	
Task 4 Append main form: 1- Service gear and availability 2- Handling maintenance	11	Service gear and availability of the vehicle must be handled by OR	DR to check if model	Clear/H001	
	12	Service gear and availability of the vehicle must be handled by OR	DR to check if model	Clear/H001	
	13	Service gear and availability of the vehicle must be handled by OR	DR to check if model	Clear/H001	
	14	Service gear and availability of the vehicle must be handled by OR	DR to check if model	Clear/H001	
	15	Service gear and availability of the vehicle must be handled by OR	DR to check if model	Clear/H001	
Task 5 Append main form: Append main form: Append main form: Append main form: Append main form:	21	DR to check if model (for which error report)	DR to check if model	Clear/H001/ Reference to calculation	
	22	DR to check if model (for which error report)	DR to check if model	Clear/H001/ Reference to calculation	
	25	DR to check if model (for which error report)	DR to check if model	Clear/H001	
	26	DR to check if model (for which error report)	DR to check if model	Clear/H001	
	23	DR to check if model (for which error report)	DR to check if model	Clear/H001/ Reference to calculation	
Task 6 Append main form: Append main form: Append main form: Append main form: Append main form:	28	DR to check if model (for which error report)	DR to check if model	Clear/H001	
	29	DR to check if model (for which error report)	DR to check if model	Clear/H001	
	30	DR to check if model (for which error report)	DR to check if model	Clear/H001	
	31	DR to check if model (for which error report)	DR to check if model	Clear/H001	
	32	DR to check if model (for which error report)	DR to check if model	Clear/H001	
Task 7 Append main form: HST/rev	33	DR to check if model (for which error report)	DR to check if model	Clear/H001	
	34	DR to check if model (for which error report)	DR to check if model	Clear/H001	
	17	DR to check if model (for which error report)	DR to check if model	Clear/H001/ Reference to calculation	
	4	DR to check if model (for which error report)	DR to check if model	Clear/H001	
	19	DR to check if model (for which error report)	DR to check if model	Clear/H001/ Reference to calculation	

REQUIREMENT : GR 15 Exahus case study for Dresser Rand **REVISION: 001**

No.	WHO	WHEN	PRIME	DEPENDENT	DIFICULTY	PRIORETY	ABSOLUT	DESCRIPTION	Test no	INFO	Test method	sucess criterion
1	DR-ØE	14.01.2014	x	no	3	1	1	The design must have dimention within the built space defined by DR	Test 1	DR to provide data.	Model revie with DR	Model accepted
2	DR-ØE	14.01.2014	x	no	1	1	1	The design must have dimention within the transport space defined by DR	Test 1	DR to provide data.	Model revie with DR	Model accepted
3	DR-ØE	14.01.2014	x	no	2	1	1	The power turbine (PT) to be used for this project is the Vectra 40G	Test 1	Input from DR, dwgs and models from the Vectra 40G is awailable through DR	Model revie with DR	Model accepted
4	DR-ØE	14.01.2014	x	no	1	1	1	The system must be designed so there is the possibility to lift in and out the PT, for maintenance purpose.	Test 1	Insulation thickness combined with the reaward CofG on PT, ther could be a problem with landing,grabbing / getting hold og the PT.	Review of new prosedure	prosedure accepted
5	DR-ØE	14.01.2014		19	1	1	1	Vent air, leak air and system air from the back of the turbine will have to be handled in an safe manner	Test 2	DR system grup to prvide data. How to get flexibles and pipe / tubing out will be a projeckt chalange. This reuirement is a bransch of the overall HSE requirement	Model revie with DR	Model accepted
6	DR-ØE	14.01.2014	x	no		3	0	Vent air, leak air and system air from the back of the turbine have to maintain the preasur according to DR spec.	Test 2	DR system group to prvide system data. Projeckt group to implement in design.	Model revie with DR	Model accepted
7	DR-ØE	14.01.2014		19	2	1	1	Oil leakage from gearbox shal not acumulate in the sorunding insulation. This is to prevent firehazards	Test 3	If insulation can absorb / accumulate flammable liquids there have to be a separat sheilding of the insulation. Drain of oil leakage will prevwnt oil retching insulation.	Model revie with DR	Model accepted
8	DR-ØE	14.01.2014	x	no	1	1	1	Light positive air pressure (value to be set by DR) to be maintained, to keep pressure against oil / bearing sealing's in adjacent equipment. (Usually gear box or compressor)	Test 3	DR to provide data. Oil seals in the gear box and compressor need some pre load from the air preasure to seal good.	Model revie with DR	Model accepted
9	DR-ØE	14.01.2014		19		1	1	The exhaust system must lead the exhaust gases out of the enclosure in a safe way.	Test 7	Try to minimize the posebillyty for leaks. And keep personel away from the gas flow.	Model revie with DR	Model accepted
10	DR-ØE	14.01.2014	x	no	1	2	1	The exhaust system must mainain the turbine enclosure ventilation. (heat emitted from the turbine is aprox 650-750kw, including approx 100kw from exhaust system)	Test 3	Enclosure ventilation main functions are for cooling the turbine and to exhaust dangerous gasses.	Model revie with DR. Calculations review with DR	Model accepted and calculation acceptedd
11	DR-ØE	15.01.2014	x	no	3	3	1	Servise and repairs of the exhaust system should be possible from the innside.	Test 4	Ethe system needs av access hatch for doind feil checks and maintenance without having to take out turbine. (maybe it could be easyer to turn out / lift of the new exhaust case.)	Model/ prosedure review with DR Service dep.	Model and or prosedure accepted
12	DR-ØE	14.01.2014	x	no	2	3	1	Servise and repairs of the exhaust system should be possible from the outside.	Test 4	It is prefered to do sevise and checks form the outside. This means that it should be access to all critical areas from the outside of the exhaust case	Model/ prosedure review with DR Service dep.	Model and or prosedure accepted
13	DR-ØE	14.01.2014	x	no	1	3	1	Change out of exhaust collector must be posible.	Test 4	It must be posible to unfasten the case from the rest of the driver package and lift it away. And to lift in a new exhaust case and alignit with the old/ existing turbine turbine.	Model/ prosedure review with DR Service dep.	Model and or prosedure accepted
14	DR-ØE	14.01.2014		15	1	3	0	Change out of the insulaton should be posible	Test 4	The integrated case must have the posebillyty to replase the old insulation aften some running houres of the turbine. This replasement should be posible without lifting out the turbine and lifting out the exhaust case it self.	Model/ prosedure review with DR engineering dep. And service dep.	Model and or prosedure accepted
15	DR-ØE	14.01.2014	x	no		2	1	Repair of the insulation shal be posible	Test 4	Repairs of parts of the insulation should be done in situ and be relatively easy.	Model/ prosedure review with DR engineering dep. And service dep.	Model and or prosedure accepted
16	DR-ØE	14.01.2014	x	no	3	1	0	Access to the oil piping, instrument flexibles and shaft coupling should not be more restricted than today.	Test 2	Space and access to the system connections in the rear of the turbin is restricted today, care should be taken so the mainnace of these connections are not made more difficult or imposible.	Model review with design dep and system group	Model and or prosedure accepted
17	DR-ØE	14.01.2014	x	no	1	1	0	Sound levels outside the package shoudl not be higher than DR spec. Usually arround	Test 7	DR to provide data.	DR to review calculation and model	Calculation and model accepted by DR
18	DR-ØE	14.01.2014	x	no	3	3	0	The geometry of the difusor will be set by DR.	Test 2	DR to provide data.	DR mech. Dep. to revieew model / geometry	Geometry accepted by DR
19	DR-ØE	14.01.2014	x	no	1	1	0	The system has to meet all of DR and customer defined HSE requirements.	Test 7	DR to provide data.	DR to review.	Acceptens form DR
20	DR-ØE	14.01.2014	x	no	3	3	0	The exhaust case system should be of a cold casing design	Test1	Old design is of hot casing design. Hot case = insulation on the outside of the casing, and cold case = insulation on the innside of the casing.	DR to review	Acceptens form DR
23	DR-ØE	14.01.2014	x	no	1	1	1	Support system for the exauast case should maintail alignment under all operations, including transient	Test 6	Gravety, turbine forcess and thermal expantion are the main drivers of equipment movement. Dont forget vibration pulsation and explotion in the exhaust case.	DR to review	Model accepted by DR
24	DR-ØE	14.01.2014	x	no	1	1	1	The exahust system should be safe to handle in respec to surfaced temprature. Max outside temp that can be tuched is 60 deg ref DNV, BV and ABS (DNV-OS_D101 Cap 2 sec. 1.5 Fire protection (Page 16) Link https://exchange.dnv.com/publishing/Codes/ToC_edition.asp#Standards) It should be easy to do the alignment of the exhaust case for first time instalment.	Test 3	Where it is expeted that personel could toucht the system it is required to not have a surfase temp over 60 degC this will require that the insulation has a design temp above 550 deg C, is suffisient thik to manage this, that there are not therman bridges and no gas leaks that can make the surface hot.	DR to send to DNV if apliccable DR to review.	Data accepted by DR and or DNV
25	DR-ØE	14.01.2014	x	no	1	1	1		Test 6	DR to provide todays prosedure for alignemnt. Done in workshop with overhead crane, and without enclosure in place.	DR Drammen and DR mech dep to review	DR to accept model
26	DR-ØE	14.01.2014			1	2	0	It should be easy to do the alignment of the exhaust case at site.	Test 6	Alignment is done in side enclosure and may restrict the avalabilty of tooling and sufisient lifting equipment	DR Drammen and DR mech dep to review	DR to accept model
27	DR-ØE	14.01.2014		19	1	1	1	The exhaust case should be safe in regard to oil leaks (leak of flammable fluids or vapour, direct or accumulative) and fire. See DNV BV ASB	Test 3	Design system with good drain system and good sheilding against penetrating fluids and flammable gasess	DR to send to DNV if apliccable DR to review.	Data accepted by DR and or DNV
28	DR-ØE	14.01.2014	x	no	2	1	1	Maintain safety of personnel and eq during operation and service in regard to the rotating shaft	test 7	Coupling to be covered	DR to review coupling cover system	DR to accept model
29	DR-ØE	14.01.2014	x	no	2	1	1	Maintain safety of personnel during operation and service in regard to hot surfasec.	Test7	Gasess from the back of turbine to be carried away from package and vented to a safe place. May be posible to vent to existing ventilation or to exhaust stack. Sound and preasure cold be difficult	DR to review	DR to accept model
30	DR-ØE	14.01.2014	x	no	2	1	1	The exhaust system must be safe to handle during fabrikcation.	Test 7		DR Kongsberg og DR Drammen to review	Model or prosedure to be accepted by DR
32	DR-ØE	14.01.2014	x	no	2	1	1	The exhaust system must be safe to handle during insatalation.	Test 7		DR Kongsberg og DR Drammen to review	Model or prosedure to be accepted by DR
33	DR-ØE	14.01.2014	x	no	2	1	1	The exhaust system must be safe to handle during alignment.	Test 7		DR Kongsberg og DR Drammen to review	Model or prosedure to be accepted by DR
34	DR-ØE	14.01.2014	x	no	2	1	1	The exhaust system must be safe to handle during transport.	Test 7		DR Kongsberg og DR Drammen to review	Model or prosedure to be accepted by DR

NO	TYPE	DATE	RESOURCESS	REQUIREMENT	DESCRIPTION	WHAT TO CONSIDER/ TO DO	DOCUMENT OUTPUT	ACCEPATNSE	ok	REVIEW	COMMENTS
Test 1	Review of model		GR 15 DR REP.	1	The design must have dimentions within the built space defined by DR	DR to check if model fits within borders sett	MOM	Closed MOM			
	Agenda / main issues: 1.- Set general modell 2.- Set main interfaces			2	The design must have dimentions within the transport space defined by DR	DR to check if model fits within borders sett	MOM	Closed MOM			
				3	The power turbine (PT) to be used for this project is the Vectra 40G	DR to check interface between exhause and turbine	MOM	Closed MOM			
				4	The system must be designed so there is the possibility to lift in and out the PT, for maintenance purpose.	DR to check interfce between crane and PT, and handling sequense	MOM	Closed MOM			
				20	The exhaust case system should be of a cold casing design	DR to check model	MOM	Closed MOM			
Test 2	Review of model		GR 15 DR REP.	5	Vent air, leak air and system air from the back of the turbine will have to be handled in an safe manner	DR to check model	MOM	Closed MOM			
	Agenda / main issues: Review of interfaces in the rear of turbine			6	Vent air, leak air and system air from the back of the turbine have to maintain the presaur according to DR spec.	DR to check model	MOM	Closed MOM			
				16	Access to the oil piping, instrument flexibiles and shaft coupling should not be more restricted than today.	DR to check model	MOM	Closed MOM			
				18	The geometry of the difusor will be set by DR.	DR to check model	MOM	Closed MOM			
Test 3	Review of model		GR 15 DR REP.	7	Oil leakage from gearthbox shal not acumulate in the sorunding insulation. This is to prevent firehazards	DR to check model	MOM	Closed MOM			
	Agenda / main issues: 1.-Insulation of case. 2.- Fire hazard 3.- Enclosure envirement			8	Light positive air pressure (value to be set by DR) to be maintained, to keep pressure against oil / bearing sealing's in adjacent equipment. (Usually gear box or compressor)	DR to check	MOM	Closed MOM			
				10	The exhaust system must maitain the turbine enclosure ventilation. (heat emitted from the turbine is aprox 650-750kw, including approx 100kw from exhaust system)	DR to check	MOM	Closed MOM			
				24	The exahust system should be safe to handle in respec to surfaced temprature. Max outside temp that can be tuched is 60 deg ref DNV, BV and ABS (DNV-OS_D101 Cap 2 sec. 1.5 Fire protection (Page 16)	DR to check	MOM	Closed MOM			
				27	The exhaust case should be safe in regard to oil leaks (leak of flammable fluids or vapour, direct or accumulative) and fire. See DNV BV ASB	DR or DNV to approve	MOM	Closed MOM			
Test 4	Review of model		GR 15 DR REP.	11	Servise and repairs of the exhaust system should be possible from the inside.	DR to check	MOM	Closed MOM			
	Agenda / main issues: 1.-Service paces and servability. 2.- Insulation maintenance			12	Servise and repairs of the exhaust system should be possible from the outside.	DR to check	MOM	Closed MOM			
				13	Change out of exhaust collector must be possible.	DR to check	MOM	Closed MOM			
				14	Change out of the insulaton should be possible	DR to check	MOM	Closed MOM			
				15	Repair of the insulation shal be possible	DR to check	MOM	Closed MOM			
Test 5	Calculation review / report review Agenda / main issues: Review of mechanical propertys of		GR 15 DR REP.	21	It should be verified that the exhaust case system will handle the thermal stresses caused by lonetime full load	DR to check calculation and / or report	MOM	Closed MOM / Released calculation			
				22	It should be verified that the exhaust case system will handle the thermal stresses caused by tranrcient condition.	DR to check calculation and / or report	MOM	Closed MOM / Released calculation			
Test 6	Review of prosedure and / or model		GR 15 DR REP.	25	It should be easy to do the alignment of the exhaust case for first time instalment.	DR to check NX sequence and model	MOM	Closed MOM			
	Agenda / main issues: Aligment prosedure			26	It should be easy to do the alignment of the exhaust case at site.	DR to check NX sequence and model	MOM	Closed MOM			
				23	Support system for the exaust case should maintail alignment under all operations, including transient	DR to check model and calculatios	MOM	Closed MOM / and/or released calculation.			
Test 7	Review of model and documets		GR 15 DR REP.	28	Maintain safety of personnel and eq during operation and service in regard to the rotating shaft	DR to check NX model and / or sequence	MOM	Closed MOM			
	Agenda / main issues: HSE review			29	Maintain safety of personnel during operation and service in regard to hot "seal air" emmissions.	DR to check NX model and / or sequence	MOM	Closed MOM			
				30	Maintain safety of personnel during operation and service in regard to hot surfasec.	DR to check NX model and / or sequence	MOM	Closed MOM			
				31	The exhaust system must be safe to handle during fabrikcation.	DR to check NX model and / or sequence	MOM	Closed MOM			
				32	The exhaust system must be safe to handle during insatalation.	DR to check NX model and / or sequence	MOM	Closed MOM			
				33	The exhaust system must be safe to handle during alignment.	DR to check NX model and / or sequence	MOM	Closed MOM			
				34	The exhaust system must be safe to handle during transport.	DR to check NX model and / or sequence	MOM	Closed MOM			
				17	Sound levels outside the package shoudl not be higher than DR spec. Usually arround	DR to check calculatium and model	MOM	Closed MOM / and/or released calculation.			
				9	The exhaust system must lead the exhaust gases out of the enclosure in a safe way.	DR to check NX model and / or sequence	MOM	Closed MOM			
				19	The system has to meet all of DR and customer defined HSE requirements.	DR to check model	MOM	Closed MOM / and/or released calculation.			

GR 15 DRESSER RAND EXHAUST CASE STUDY
RISK ANALYSES

Version 001

Author: David Lybek

09. Feb.2014

Introduction

This document has been done to reduce risk of failure of the project

Key Terms

The following table provides definitions for terms relevant to this document.

Term	Definition
<i>DR</i>	<i>Dresser Rand</i>
<i>Spec.</i>	<i>Specification</i>
<i>HSE</i>	<i>Health, Safety, Environment</i>
<i>Plenum</i>	<i>Air box before turbine</i>
<i>Enclosure</i>	<i>Enclosed room for turbine / equipment</i>
<i>Driver</i>	<i>Equipment providing the mechanical power</i>
<i>Package</i>	<i>The complete equipment providing the mechanical power</i>

Document revision history

Version #	Implemented By	Revision Date	Approved By	Approval Date	Reason
001	<i>DLY</i>	<i>09.feb.14</i>	<i>DLY</i>	<i>09.FEB.14</i>	Initial rev 001

1 Introduction

Risk is the multiplication of probability and consequences

Higher the probability and consequence, then the higher the risk will be.

The risk analyses will be performed in spreadsheet appendix 1 and 2.

Main conclusions are summarized in analyses.

Appendix A: References

The following table summarizes the documents referenced in this document.

Document Name and Version	Description	Location
<i>Riskasasment001.xlsx</i>	<i>XLSX file of Risk analyses BSc thesis</i>	 Riskasasment001.xlsx
<i>Riskasasment001.xlsx</i>	<i>Print of Risk analyses BSc thesis</i>	<i>Appendix b</i>

Appendix B: Copy of spreadsheet

UTGAVE:001	UTFØRT AV: DLY	DATE: 03.02.14	EVENTUALLY: GR 16 EXHAUST CASE DRESSER RAND								
SITUASJON / ACTIVITY			UNWANTED HEMDELSE	KONSEKVENNS	RISK	SANSVARETS REDUSERTNED OG ELLER RISKORREDUSERTNED TILTAK	NY RISK VURDERING	KONSEKV	RISK	DU DATE	RESPONSIBLE
Gruppe arbeid	1	Sykdom	slow progression	5	keep each other orientated		2	1,5	3	v/8	DLY / GN
Gruppe arbeid	2	data forsvinner	slow or no progress	5	take back up		2	1	2	on-going	DLY / GN
Workshop	3	ujulke	tap av liv og helse	3	Safety moment og sja		1	1	1	when applicable	DLY / GN
Gruppe arbeid	4	utdrøpping av skole	deltager blir alone, difficulty with group work	3	holde hverandre orientert, and talk to HBV asap after incident		1	1	1	hen applicab	DLY / GN
prosjekt arbeid	5	bedrift medlemmer	vi blir uten prosjekt	2	Ha reserve extern sensor i reserve		1	1	1	hen applicab	DLY / GN
Prosjekt arbeid	6	blir sakt opp	Får mere tid til BS oppgave	3	Gjøre en god jobb.		1	OK	0	v/8	DLY / GN
BS oppgave	7	bedriften går konkurs	vi blir uten prosjekt, bedrift blir ikke utørt	2	Ha backup av alle dokumenter så det går ann og fullføre prosjektet uten oppinnelig bedrift		1	1	1	v/8	DLY / GN
Gruppe arbeid	8	gruppa fungerer ikke	arbeid blir ikke utørt	4	ha mange møter og kommuniser mye					v/8	DLY / GN
Gruppe arbeid	9	gruppa fungerer ikke	gruppa styrker	3	dokumentere egen innsats, gjøre egne betraktninger, gjøre egne notater underveis, for å eventuelt dokumentere prosjektet på egenhånd overfor HBV og Dppdagsgjver senere		1	1	1	on-going	DLY / GN
Gruppe arbeid	10	gruppa fungerer ikke mot veileder	deler av karakter kan ødelegges	4	samtaler med skole, blytte veileder, blytte prosjekt.		1	1	1	v/8	DLY / GN
Gruppe arbeid	11	gruppa fungerer ikke mot veileder	prosjektet / studie kan ødelegges	4	samtaler med skole, blytte veileder, blytte prosjekt.		1	1	1	v/8	DLY / GN
Prosjekt arbeid	12	Prosjekt kompetanse gjøres ikke tilgjengelig	læringsutbytte blir forsvarende, prosessene kan ødelegges	3	Snakk med skolen tidlig, snakk med extern veileder tidlig. For å tilgjenge søg kompetanse på egen hånd		1	1	1	on-going	DLY / GN
prosjekt arbeid	13	Krangling intern	Framdrift stopper opp	4	Tidlig samtaler med skole		1	1	1	on-going	DLY / GN
prosjekt arbeid	14	Krangling med veileder	deler av karakter kan ødelegges	3	Tidlig samtaler med skole		1	1	1	v/8	DLY / GN
prosjekt arbeid	15	datamaskin blir stjålet	prosjektet stopper	5	Ta sikkerhetskopii av arbeidet ofte		2	1	1	v/9	DLY / GN
Prosjekt arbeid	16	Prosjekt ide blir stjålet	Prosjektet synker i merveid for DR	2,5	Være forsiktig med hvem man deler info med		1	1	1	on-going	DLY / GN
Prosjekt arbeid	17	Prosjekt ide er patent beskyttet fra	Prosjektet synker i	2,5	Gjøre patent søk og teknologisk søk på forhånd.		1	1	1	ASAP	DLY / GN
Prosjekt arbeid	18	Oppgaven er for stor	Blir umning å fullføre oppgaven	4	Gjøre prosjektet så inkrementelt og skalerbart som mulig, slik at merveid hele tiden genereres.		1	1	1	on-going	DLY / GN
Prosjekt arbeid	19	Oppgaven blir for stor	man mister oversikten	4	Gjøre oppgaven skalerbar og inkrementell, slik at alle deler av prosjektet blir gjennomlebare og oversiktlige.		1	1	1	on-going	DLY / GN
Prosjekt arbeid	20	Oppgaven blir for stor.	man mister motivasjon.	4	Gjøre oppgaven skalerbar og inkrementell, slik at alle deler av prosjektet blir gjennomlebare og oversiktlige.		1	1	1	on-going	DLY / GN
Presangasjon	21	Data trøbel	framføring blir dårlig	5	Gjennom presangasjon på aktueltrom på skolen. Test infrastruktur på forhånd		2	1	2	ASAP	DLY / GN
presentasjon	22	Nærvæst sammenbrudd	framføring blir dårlig	5	Vær ærlig og si at det vet hvilke å gå videre		2	2	4	ASAP	DLY / GN
Presangasjon	23	Vanskelig spørsmål	Virker utbrobert	5	Kom med forslag til spørsmål til extern sensor og intern veileder.		2	2	4	v/8	DLY / GN

- Conclusions:
- 1.- make the projekt incremental / evolutionary and scalable.
 - 2.- Find ways to communicate easy. Cloud services.
 - 3.- If there is any trouble talk to HBV asap.

UTGAVE: 001		UTFØRT AV: DLY		DATO: 03.02.14		EVENTUALLY: GR 15 EXHAUST CASE DRESSER RAND RISK ANALYSIS OF BSC PROJECT				
						NY RISK VURDERING				
SITUASJON / ACTIVITY	NO	UNWANTED HENDELSE	KONSEKVENS	Risk	SANSYNIGHETS REDUSERENDE OG/ ELLER RISIKOREDUSERENDE TILTAK	SANSYLIGHET	KONSEKVENS	RISK	DU DATE	RESPONSIBLE
Gruppe arbeid	1	Sykdom	slow progression	5	keep each other orientated	2	1,5	3	W8	DLY / GN
Gruppe arbeid	2	data forsvinner	slow or no progress	5	take back up	2	1	2	on-going	DLY / GN
Visit workshop	3	ulykke	tap av liv og helse	3	Safety moment og sja	1	1	1	when applicable	DLY / GN
Gruppe arbeid	4	utdropping av skole	deltager blir alene, difficulty with group work	3	holde hverandre orientert, and talk to HBV asap after incident	1	1	1	when applicable	DLY / GN
prosjekt arbeid	5	bedrift nedbemanner	vi blir uten prosjekt	2	Ha reserve extern sensor i reserve	1	1	1	when applicable	DLY / GN
Prosjekt arbeid	6	blir sakt opp	Får mere tid til BS oppgave	3	Gjøre en god jobb.	1	OK	0	W8	DLY / GN
BS oppgave	7	bedriften går konkurs	vi blir uten prosjekt, bedrift og sensor	2	Ha backup av alle dokumenter så det går ann og fullføre prosjektet uten opprinelig bedrift	1	1	1	W8	DLY / GN
Gruppe arbeid	8	gruppa fungerer ikke	arbeid blir ikke utført	4	ha mange møter og komuniser mye				W8	DLY / GN
Gruppe arbeid	9	gruppa fungerer ikke	gruppa stryker	3	dokumentere egen innsats, gjøre egne betraktninger, gjøre egne notater underveis, for å eventuelt dokumentere prosjektet på egenhånd ovenfor HBV og Oppdragsgiver senere	1	1	1	ongoing	DLY / GN
Gruppe arbeid	10	gruppa fungerer ikke mot veileder	deler av karakter kan ødelegges	4	samtaler med skole	1	1	1	W8	DLY / GN
Gruppe arbeid	11	gruppa fungerer ikke mot veileder	prosjektet / studie kan ødelegges	4	samtaler med skole, bytte veileder, bytte prosjekt.	1	1	1	W8	DLY / GN
Prosjekt arbeid	12	Prosjekt kompetanse gjøres ikke tilgjengelig	læringsutbytte blir fraværende, prosessene kan stoppe opp	3	Snakk med skolen tidlig, snakk med extern veileder tidlig. Prov å tilegne seg kompetanse på egen hånd	1	1	1	ongoing	DLY / GN
prosjekt arbeid	13	Krangling internt	Framdrift stopper opp	4	Ta egne notater og snakk med veileder på skole og bedrift (forklar situasjon)	1	1	1	ongoing	DLY / GN
prosjekt arbeid	14	Krangling med veileder	deler av karakter kan ødelegges	3	Tidlig samtaler med skole	1	1	1	W8	DLY / GN
prosjekt arbeid	15	datamaskin blir stjålet	prosjektet stopper opp	5	Ta sikkerhets kopi av arbeidet ofte	2	1	1	W9	DLY / GN
Prosjekt arbeid	16	Prosjekt ide blir stjålet.	Prosjektet synker i merverdi for DR	2,5	Være forsiktig med hvem man deler info med.	1	1	1	ongoing	DLY / GN
Prosjekt arbeid	17	Prosjekt ide er patent beskyttet fra før	Prosjektet synker i verdi	2,5	Gjøre patent søk og teknologisk på forhånd.	1	1	1	ASAP	DLY / GN
Prosjekt arbeid	18	Oppgaven er for stor	Blir umilig å fullføre oppgaven	4	Gjøre prosjektet så inkrementelt og skalerbart som mulig, slik at merverdi hele tiden generers.	1	1	1	ongoing	DLY / GN
Prosjekt arbeid	19	Oppgaven blir for stor	man mister oversikten	4	Gjøre oppgaven skalerbar og inkrementell, slik at alle deler av prosjektet blir gjennomførbare og oversiktlige.	1	1	1	ongoing	DLY / GN
Prosjekt arbeid	20	Oppgaven blir for stor.	man mister motivasjon.	4	Gjøre oppgaven skalerbar og inkrementell, slik at alle deler av prosjektet blir gjennomførbare og oversiktlige.	1	1	1	ongoing	DLY / GN
Presangtasjon	21	Data trøbel	framføring blir dårlig	5	Gå igjennom presangtasjon på aktuell rom på skolen. Test it-infrastruktur på forhånd	2	1	2	ASAP	DLY / GN
presentasjon	22	Nærvøst sammenbrudd	framføring blir dårlig	5	Gå igjennom presangtasjon på forhånd. ØV på framføringen.	2	2	4	ASAP	DLY / GN
Presangtasjon	23	Vanskelig spørsmål	Vi virker uforbrett	5	Vær ærlig og si at det vet vi ikke, å gå videre. Kom med forslag til spørsmål til extern sensor og intern veileder.	2	2	4	W8	DLY / GN

Conclusions:

- 1.- make the project incremental / evolutionary and scalable.
- 2.- Find ways to communicate easy. Cloud services.
- 3.- If there is any trouble talk to HBV asap.

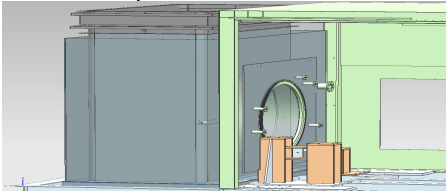
Møtedato / Date of meeting 07.04.14	Kl / Time 1200-1500	Sted / Location DRK	Nr / No 001
Prosjekt / Project DR exhaust case Test 1 Agenda / main issues: 1.- Set general model 2.- Set main interfaces			
Møteleder / Meeting requested by DLY	Referent / Minuted by dly	Dato / Date 07.03.14	
Deltakere / Participants DLY, IHA, SYT			
Kopi til /Copy to GN			
Pkt / Item no	Referat / Minutes	Ansv. /Resp.	Tid /Date
01	REQUIREMENT no 1: The design must have dimensions within the built space defined by DR. Comments: Has been set as small at possible for initial built space reservation, could change later. OK	OK	07.04.14
02	REQUIREMENT no 2: The design must have dimensions within the transport space defined by DR. Comments: Include minimum HEA 300 + pads for Russian train transport. OK	OK	07.04.14
03	REQUIREMENT no 3: The power turbine (PT) to be used for this project is the Vectra 40G. Comments: OK	OK	07.04.14
04	REQUIREMENT no 4: The system must be designed so there is the possibility to lift in and out the PT, for maintenance purpose. Comments: OK position of jib crane and PT are standard.	OK	07.04.14
05	REQUIREMENT no 20: The exhaust case system should be of a cold casing design. Comments: OK but no details defined yet.	OK	07.04.14
Modell snap shot 			

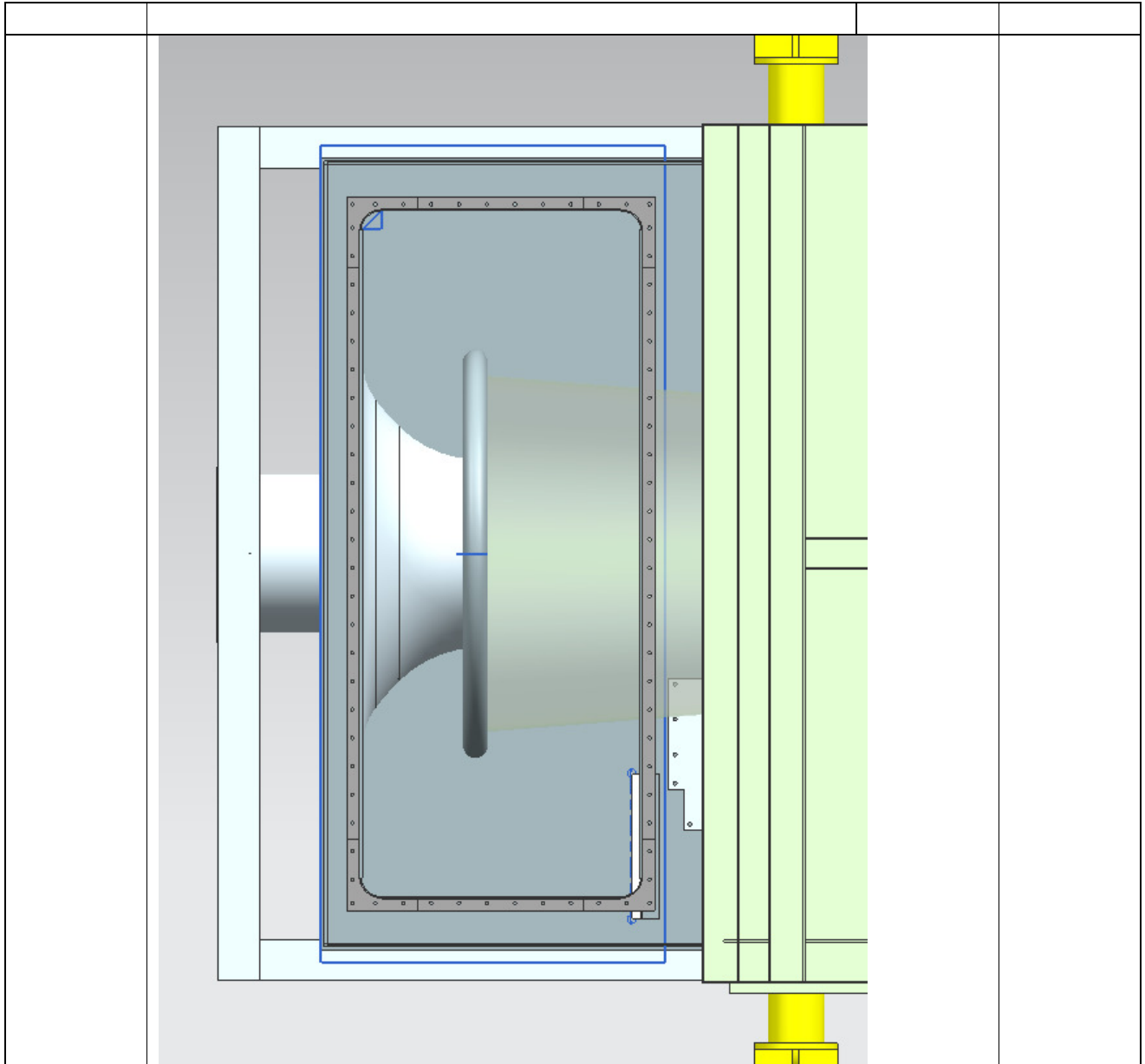

For å legge til flere linjer: Plasser kursor i nedre høyre celle, under "Tid/Date", og trykk på tab-knappen.
To add more lines: Place cursor in lower right hand cell, below "Tid/Date", and press tab. (Delete this text when finished)

Møtedato / Date of meeting	Kl / Time	Sted / Location DRK	Nr / No
Prosjekt / Project DR exhaust case Test 2' Review of interfaces in the rear of turbine			
Møteleder / Meeting requested by xxx	Referent / Minuted by xxx	Dato / Date xx	
Deltakere / Participants xx			
Kopi til /Copy to xx			
Pkt / Item no	Referat / Minutes	Ansv. /Resp.	Tid /Date
01	<p>REQUIREMENT no 5: Vent air, leak air and system air from the back of the turbine will have to be handled in an safe manner.</p> <p>Tomasz Sarnowski: Kommentere at det skal ikke I utgangspunktet ikke være noen lekkasje igjennom eksos kasse tetning I tunnelen, eller noen form for tette luft fra aksel. Men erfaring viser at slitasje fører til lekkasje igjennom denne tetning. PN1041-MSP er første anlegg med redesignet tetning for å minimerer denne slitasjen.</p>  <p>SYT: Sier at det er best hvis det kan være ventileret til atmosfære, med perforert plate som lukker rommet bak i tunnelen.</p>  <div data-bbox="873 1491 1112 1942" style="border: 1px solid black; padding: 5px;"> <p>Perforert plate som naturlig ventilasjon hadde vært det enkleste. Det kan være noen problemer med dette</p> <ul style="list-style-type: none"> -Lyd. -gass lekkasje. -varme overflater. -lekkasje av olje damp som over tid akkumuleres. -trykk / luft strøm mot gir tetning. </div>	OK	DLY / ØE

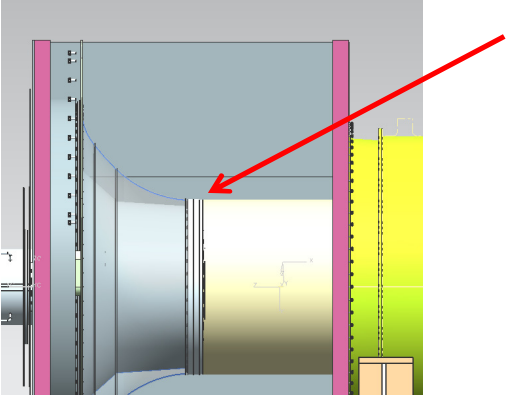
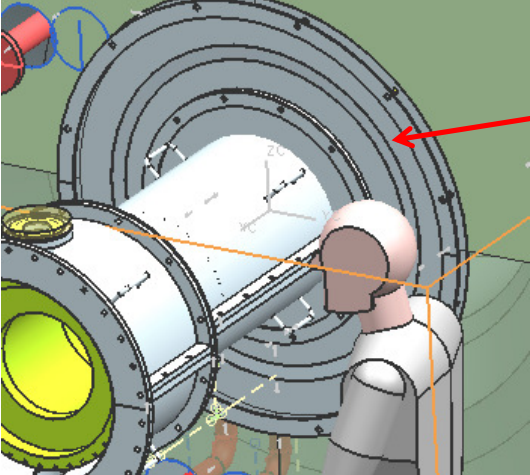

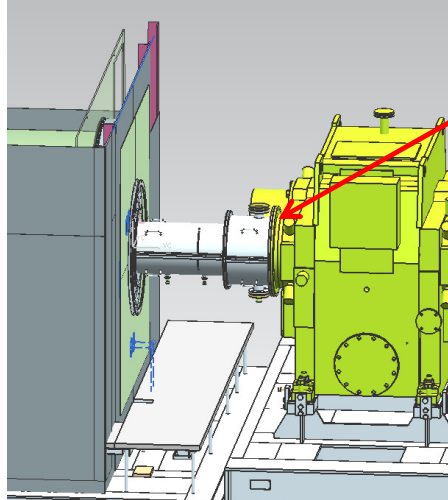
Lekk fra kompressor aksel-tetning kan bli ganske stor. I motsetning til gir tetningen som holder relativt sett tett.

Vanligvis har kompressor nye høyere lekkasje ut av aksel lager og tetning, en girkasse. Lekkasje inneholder olje og dette fører til at man må ta vare lekkasjen, og håndtere denne på en forsvarlig og fornuftig måte.

I de fleste tilfeller vil det si, ventilasjon til atmosfære og drenering til atmosfærisk drip-tray.

Der foreslås at drip tray avsluttes så det ikke kan dryppe / renne olje inn i isolasjonen.

Dette kan løses med et driptray i bunnen an tunnel rommet.

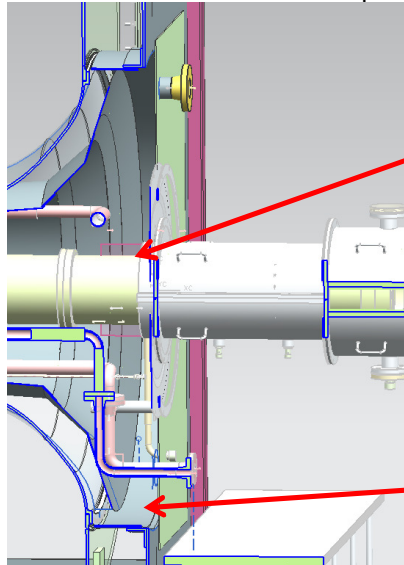

Tunnel kan avsluttes så det ikke drypper in/ ned i isolasjonen

Lag driptray med drenering her for at ikke olje skal samle seg i isolasjonen.

Lekkasje fra kompressor/ gir og PT er av forskjellig kvalitet. PT har syntetisk olje og gir / kompressor og generator bruker mineral smøre olje. Disse oljene må ikke blandes, dette fører til at en eventuell ventilasjon av tunnel rommet ikke kan føres igjennom noen av olje-utskillere (demisterene) som er på pakka.

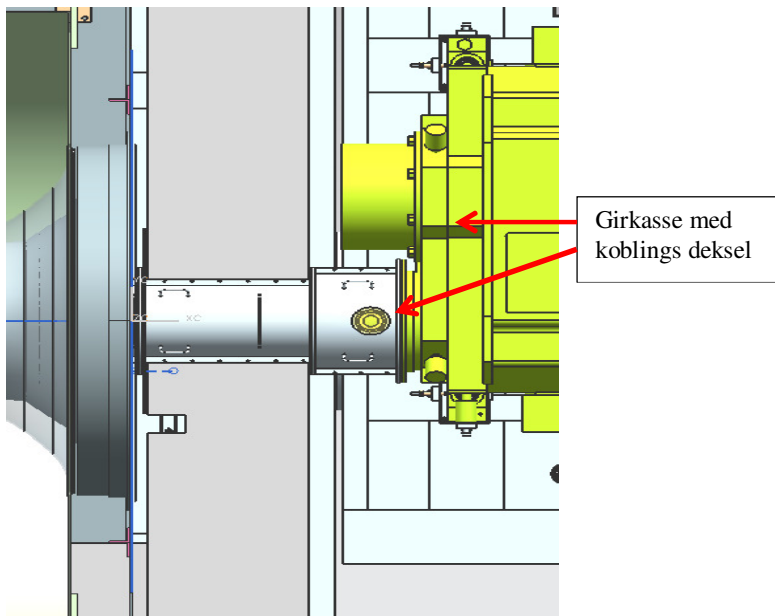
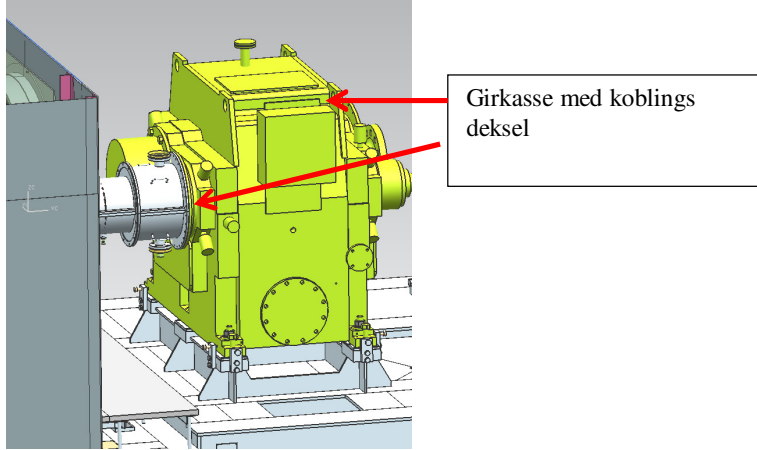

Comments:

OK.

Øyvind Eidsmoen kommenterer.

At vi designer denne med tett plate og tett flex / duk, både olje og så gass tett som mulig. Dette fører til at vi må inn med ventilasjon.

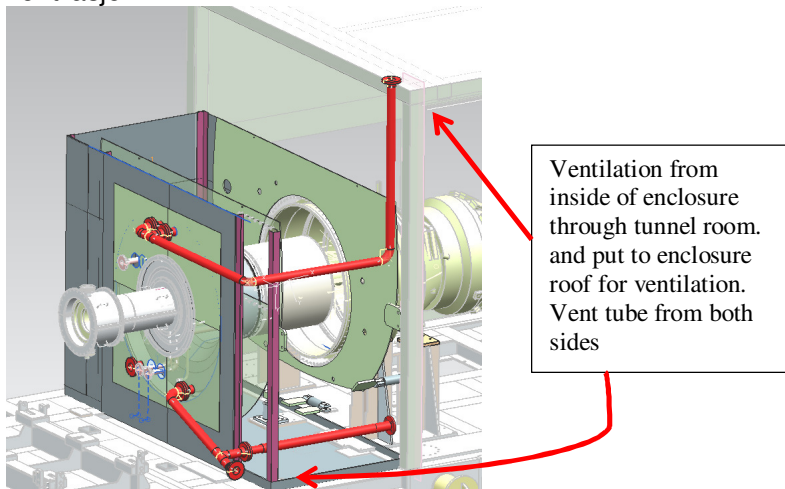

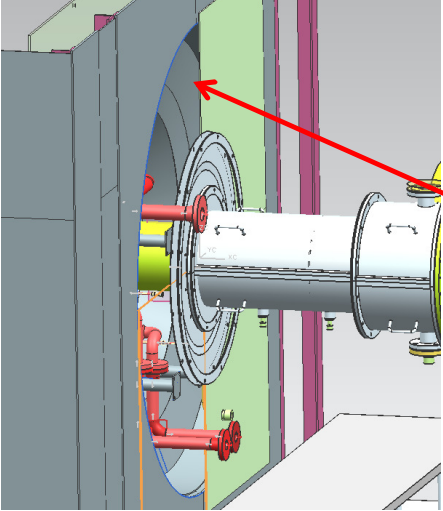
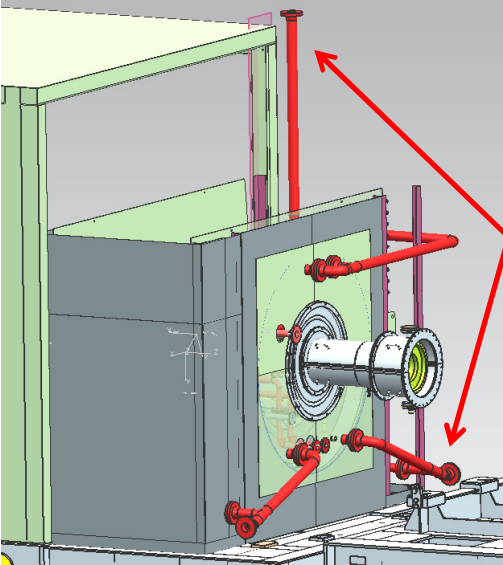
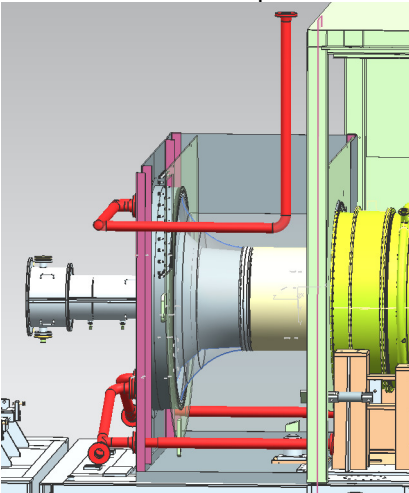
	 <p data-bbox="859 260 1052 459">Dette rommet designes tett med mulighet for ventilasjon</p>  <p data-bbox="846 863 1118 1255">Ventilasjon fra enclosure på begge sider. Og utlufting over enclosure tak. Dette fører til at vi kan opprettholde den atmosfæren vi ønsker enteni tunnel rommet, ved å ta fra enclosure eller ved å sette på en selvstendig vifte ref Øyvind Eidsmoen</p>		
<p>02</p>	<p>REQUIREMENT no 6: Vent air, leak air and system air from the back of the turbine have to maintain the pressure according to DR spec.</p>  <p>Comments: OK No leak and no pressure requirements is nominal but, ther is</p>	<p>OK</p>	<p>DLY / SYT</p>

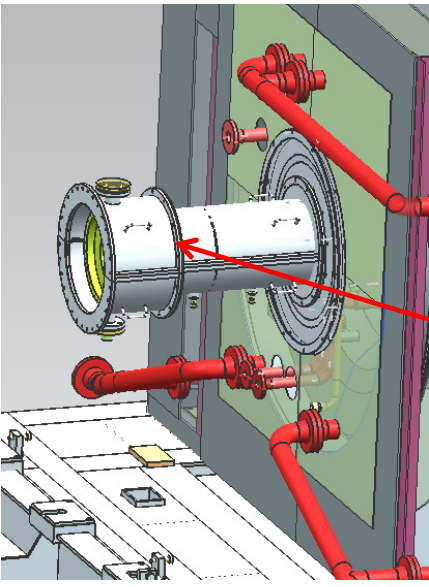
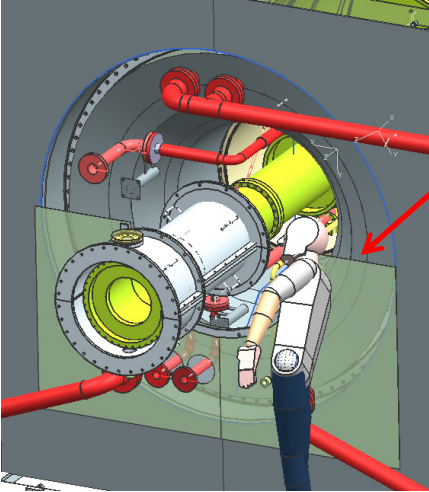
	<p>now a closed room in the back, that could be vented. The leakage from the compressor seal is more important. and this is handled by coupling cover</p>  <div data-bbox="808 583 1031 724" style="border: 1px solid black; padding: 5px;"> <p>Leak from gir and compressor is handled by coupling cover</p> </div>		
<p>03</p>	<p>REQUIREMENT no 16: Access to the oil piping, instrument flexible and shaft coupling should not be more restricted than today.</p> <p>Comments:</p>  <div data-bbox="816 1176 1079 1360" style="border: 1px solid black; padding: 5px;"> <p>Maybe the split on the rear cover should be different. Maybe rotate and split in 3 instead of 4</p> </div>	<p>OK</p>	<p>DLY / IHA</p>
<p>04</p>	<p>REQUIREMENT no 18: The geometry of the difusor will be set by DR.</p> <p>Comments: diffusor sinning geometry is standard for V-40G</p>	<p>OK</p>	<p>DLY</p>

	<p>Expansion joint materials have differing coefficient of expansion values to</p> <hr/> <p>Nettet Bilder Google Maps Mer ▾ Innstillinger for søket</p> <hr/> <p>Omtrent 1 470 resultater (0,54 sekunder)</p> <p>Viser resultater for Expansion joint materials have differing coefficient of expansion values to that of their metal frame counterparts and so considerable stress can be induced into the materials if the design does not cater for this</p> <p>Søk heller etter Expansion joint materials have differing coefficient of expansion values to that of their metal framecounterparts and so considerable stress can be induced into the materials if the design does notcater for this</p> <hr/> <p>^[PDF] Expansion joint problems & solutions - James Walker www.jameswalker.biz/.../80-expansion-joint-proble... ▾ Oversett denne siden Early expansion joint frame designs were based on the typical coal fired A Preset the duct flanges so that the single expansion joint is exposed to +/- ... Expansion joint materials have differing coefficient of expansion values to that of their metal ... considerable stress can be induced into the materials if the design does not.</p>		

For å legge til flere linjer: Plasser kursor i nedre høyre celle, under "Tid/Date", og trykk på tab-knappen.
To add more lines: Place cursor in lower right hand cell, below "Tid/Date", and press tab. (Delete this text when finished)

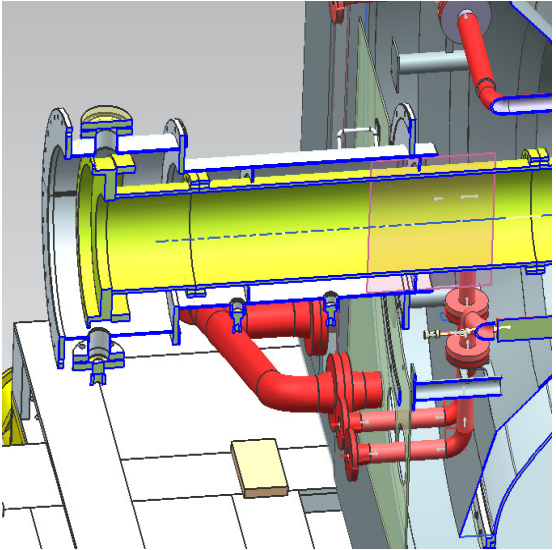
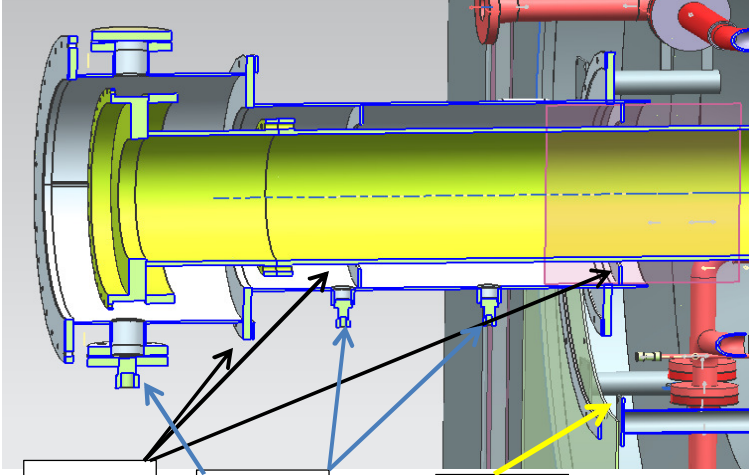
Møtedato / Date of meeting	Kl / Time	Sted / Location DRK	Nr / No
Prosjekt / Project DR exhaust case Test 3 1.-Insulation of case 2.-Fire hazard 3.- enclosure environment			
Møteleder / Meeting requested by	Referent / Minuted by	Dato / Date	
Deltakere / Participants DLY,			
Kopi til /Copy to			
Pkt / Item no	Referat / Minutes	Ansv. /Resp.	Tid /Date
01	<p>REQUIREMENT no 7: Oil leakage from gearbox shall not accumulate in the sounding insulation. This is to prevent fire hazards.</p> <p>Comments:</p>  <div data-bbox="917 871 1161 1249" style="border: 1px solid black; padding: 5px;"> <p>If there is a leak the oil must first pas 3 drain holes and 3 coupling cover baffles. This should be sufficient. But if there are oil passing these obstacles there should be a drip tray inside the exhaust case tunnel room</p> </div>  <div style="display: flex; justify-content: space-around; margin-top: 10px;"> <div data-bbox="381 1911 519 1963" style="border: 1px solid black; padding: 2px;">baffles</div> <div data-bbox="560 1911 698 1963" style="border: 1px solid black; padding: 2px;">drains</div> <div data-bbox="795 1911 933 1963" style="border: 1px solid black; padding: 2px;">driptray</div> </div>	OK	DLY / IHA

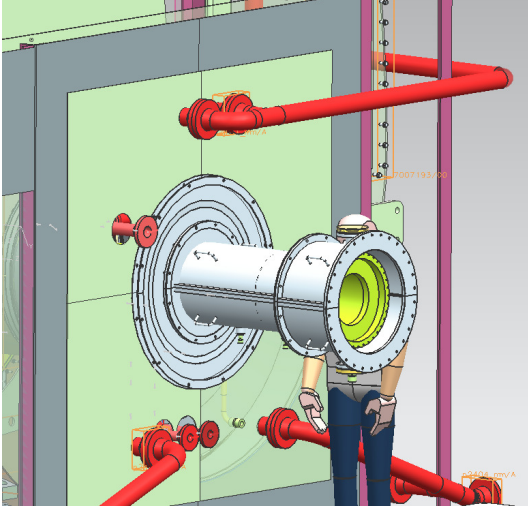
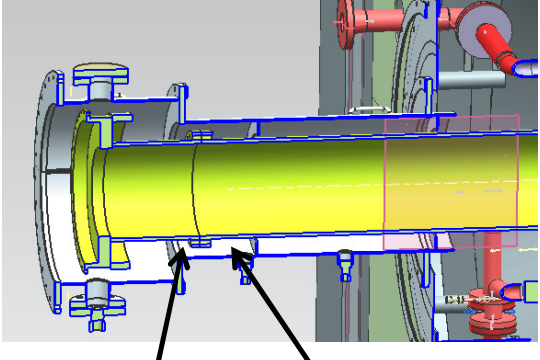
<p>02</p>	<p>REQUIREMENT no 8: Light positive air pressure (value to be set by DR) to be maintained, to keep pressure against oil / bearing sealing's in adjacent equipment. (Usually gear box or compressor)</p> <p>Comments: OK</p>   <div data-bbox="950 483 1123 718" style="border: 1px solid black; padding: 5px;"> <p>This is now easier than before since we closed the rear room, mean better control.</p> </div> <div data-bbox="365 1339 1076 1453" style="border: 1px solid black; padding: 5px;"> <p>We try to regulate flow with internal coupling cover baffles. Depending on side of bolts the baffles are mounted the flow will change</p> </div>	<p>OK</p>	<p>Dly / IHA</p>
<p>03</p>	<p>REQUIREMENT no 10: The exhaust system must maintain the turbine enclosure ventilation. (heat emitted from the turbine is approx. 650-750kw, including approx. 100kw from exhaust system)</p> <p>Comments: OK and not necessary, the old system did not include exhaust system heat in to the dimensioning of the vent fans. So this will have almost no effect on the vent fan size. Since the turbine is before the exhaust case heat is emitted to the enclosure air.</p> <p>Air circulation and turbulent pocket of air in the enclosure is a bigger problem.</p>	<p>OK</p>	<p>DLY / IHA / ØE</p>

For å legge til flere linjer: Plasser kursor i nedre høyre celle, under "Tid/Date", og trykk på tab-knappen.

To add more lines: Place cursor in lower right hand cell, below "Tid/Date", and press tab. (Delete this text when finished)

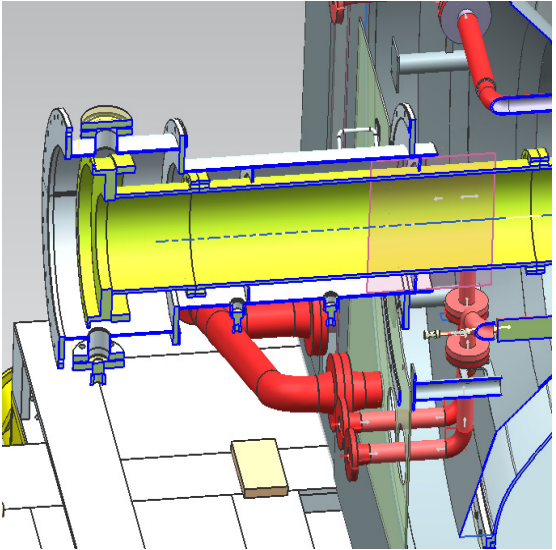
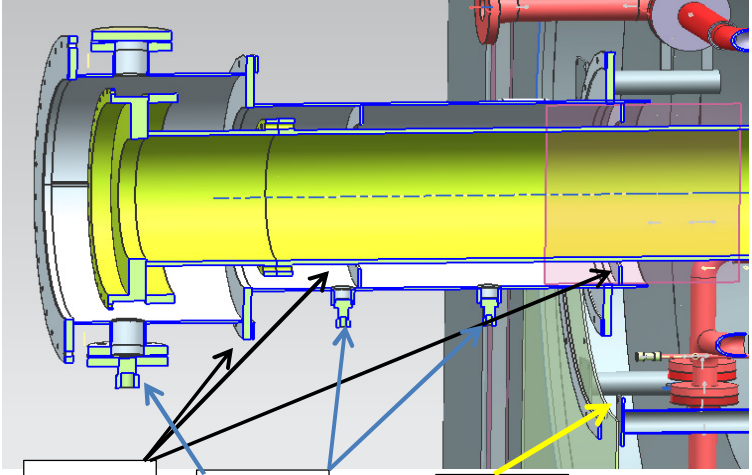
Møtedato / Date of meeting	Kl / Time	Sted / Location DRK	Nr / No
Prosjekt / Project DR exhaust case Test 3 1.-Insulation of case 2.-Fire hazard 3.- enclosure environment			
Møteleder / Meeting requested by	Referent / Minuted by	Dato / Date	
Deltakere / Participants DLY,			
Kopi til /Copy to			
Pkt / Item no	Referat / Minutes	Ansv. /Resp.	Tid /Date
01	<p>REQUIREMENT no 7: Oil leakage from gearbox shall not accumulate in the sounding insulation. This is to prevent fire hazards.</p> <p>Comments:</p>  <div data-bbox="917 871 1161 1249" style="border: 1px solid black; padding: 5px;"> <p>If there is a leak the oil must first pas 3 drain holes and 3 coupling cover baffles. This should be sufficient. But if there are oil passing these obstacles there should be a drip tray inside the exhaust case tunnel room</p> </div>  <div style="display: flex; justify-content: space-around; margin-top: 10px;"> <div data-bbox="389 1911 519 1963" style="border: 1px solid black; padding: 2px;">baffles</div> <div data-bbox="560 1911 690 1963" style="border: 1px solid black; padding: 2px;">drains</div> <div data-bbox="795 1911 925 1963" style="border: 1px solid black; padding: 2px;">driptray</div> </div>	OK	DLY / IHA

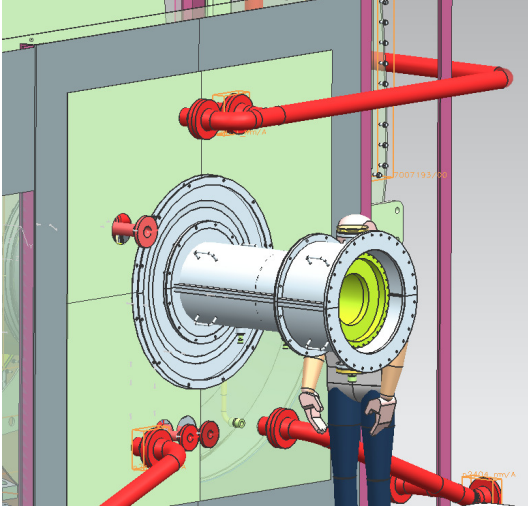
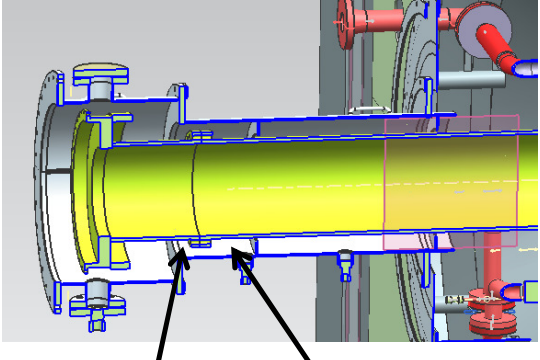
<p>02</p>	<p>REQUIREMENT no 8: Light positive air pressure (value to be set by DR) to be maintained, to keep pressure against oil / bearing sealing's in adjacent equipment. (Usually gear box or compressor)</p> <p>Comments: OK</p>   <div data-bbox="950 483 1123 718" style="border: 1px solid black; padding: 5px; width: fit-content;"> <p>This is now easier than before since we closed the rear room, mean better control.</p> </div> <div data-bbox="365 1339 1076 1453" style="border: 1px solid black; padding: 5px;"> <p>We try to regulate flow with internal coupling cover baffles. Depending on side of bolts the baffles are mounted the flow will change</p> </div>	<p>OK</p>	<p>Dly / IHA</p>
<p>03</p>	<p>REQUIREMENT no 10: The exhaust system must maintain the turbine enclosure ventilation. (heat emitted from the turbine is approx. 650-750kw, including approx. 100kw from exhaust system)</p> <p>Comments: OK and not necessary, the old system did not include exhaust system heat in to the dimensioning of the vent fans. So this will have almost no effect on the vent fan size. Since the turbine is before the exhaust case heat is emitted to the enclosure air.</p> <p>Air circulation and turbulent pocket of air in the enclosure is a bigger problem.</p>	<p>OK</p>	<p>DLY / IHA / ØE</p>

For å legge til flere linjer: Plasser kursor i nedre høyre celle, under "Tid/Date", og trykk på tab-knappen.

To add more lines: Place cursor in lower right hand cell, below "Tid/Date", and press tab. (Delete this text when finished)

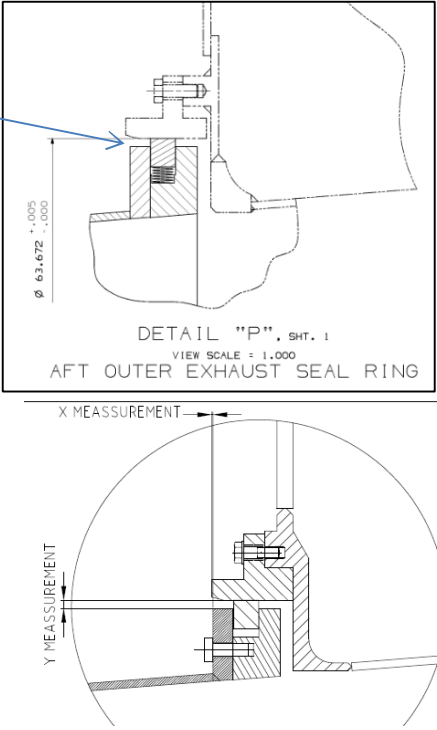
Møtedato / Date of meeting	Kl / Time	Sted / Location DRK	Nr / No
Prosjekt / Project DR exhaust case Test 4 1.-Service paces and servability. 2.- Insulation maintenance			
Møteleder / Meeting requested by DLY	Referent / Minuted by dly	Dato / Date	
Deltakere / Participants DLY,			
Kopi til /Copy to			
Pkt / Item no	Referat / Minutes	Ansv. /Resp.	Tid /Date
01	<p>REQUIREMENT no 11: Service and repairs of the exhaust system should be possible from the inside.</p> <p>Comments: The important task to be performed is field alignment of exhaust case. This is done with feeler gauges between the PT and the exhaust case, in four places.</p> <div data-bbox="402 1050 662 1239" style="border: 1px solid black; padding: 5px; width: fit-content;"> <p>Feeler gauge is used here to do in situ alignment check of exhaust cases Typically done 4 places</p> </div> 	<p>OK</p> <p>But needs more focus later to determine inside enclosure cladding for the case</p>	DLY / IHA

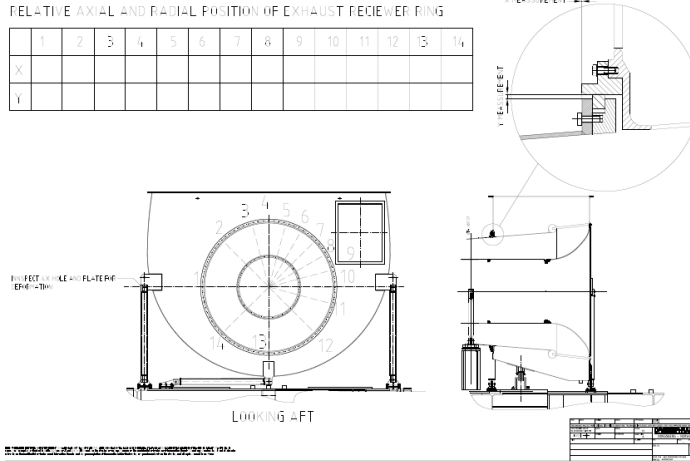

Illustration showing typical field measurement check. Access to do this check at 4 quadrant must not be worse than today.



Pic showing in field receiver ring installation



Pic showing in field receiver ring installation

02

REQUIREMENT no 12:
Service and repairs of the exhaust system should be possible from the outside.

Comments:

All panels should be bolted and this will dramatically increase the services access of the case.
Use hatch on side instead of in the back.

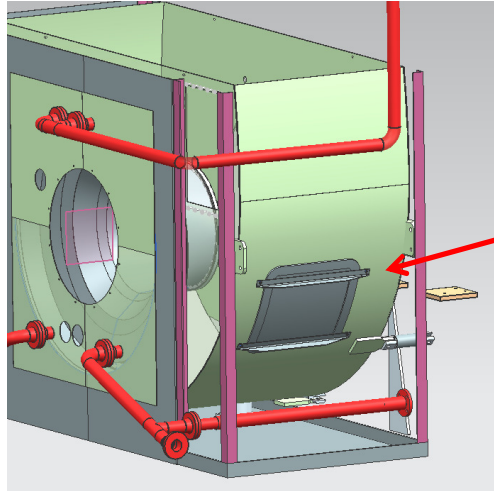

Side Hatch
for increased
Access

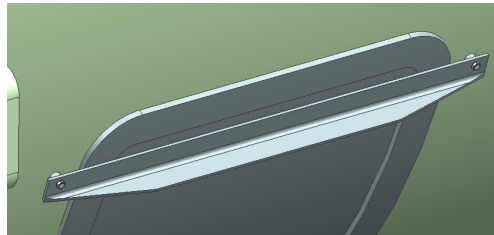

Side Hatch redesigned
for minimum of welds
and low temp gradient
in material.
Cover needs gasket

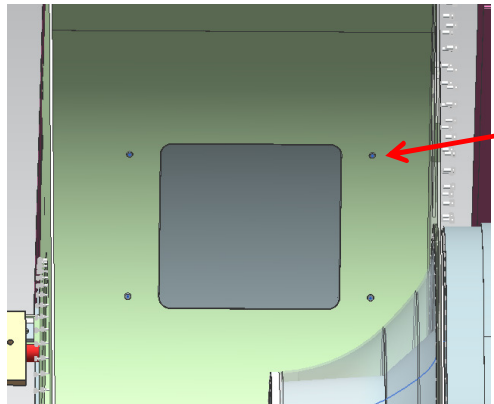

Hatch from the inside

4x Nutt boss to intrude
in to the case for
increased heat input to
compensate for
material thickness
change

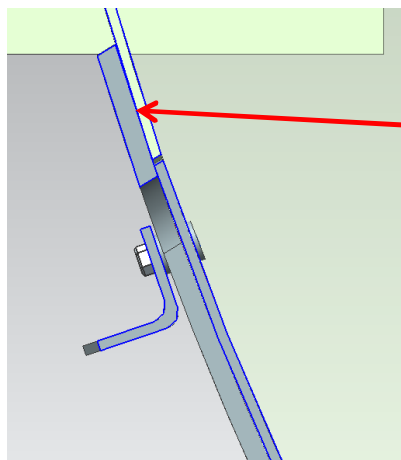

Hatch section

Gasket not showed

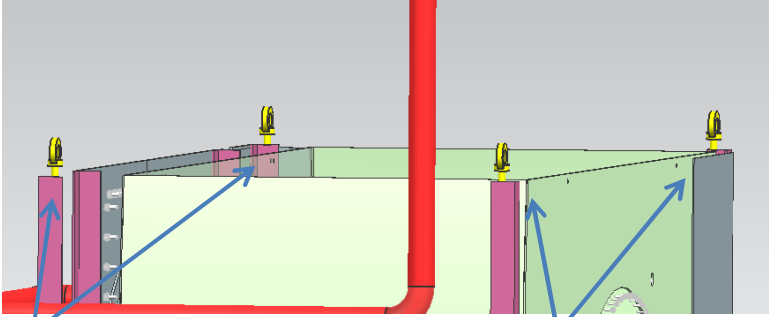
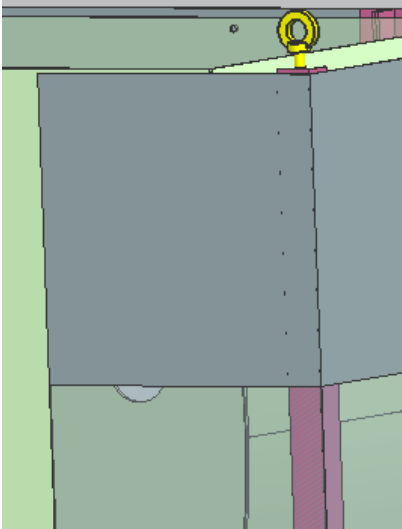
<p>03</p>	<p>REQUIREMENT no 13: Change out of exhaust collector must be possible.</p> <p>Comments: This should be easier with the new system. Include lifting point with eye bolts.</p>  <p>4x eyebolts included to make handling / lifting and transport safe and easy.</p>		
<p>04</p>	<p>REQUIREMENT no 14: Change out of the insulation should be possible.</p> <p>Comments: Outer cladding should be bolted and this is ok Not finished with the slitting off the panels, but should not be a problem. Use vertical joints in panelwere possible.</p> 		
<p>05</p>	<p>REQUIREMENT no 15: Repair of the insulation shall be possible.</p> <p>Comments: Bolted cladding makes this easy</p>		

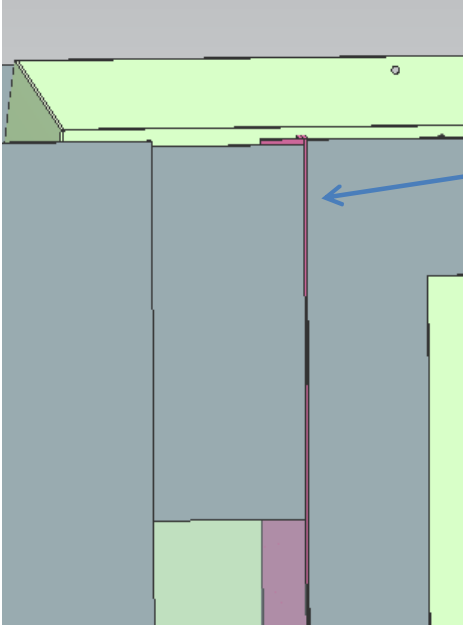
	 <p>The diagram shows a cross-section of a wall assembly. At the top is a grey horizontal layer. Below it is a light green sloped layer. The main wall body consists of several vertical layers: a grey layer on the left, a grey layer in the middle, a purple vertical strip, another grey layer, and a light green layer on the right. A blue arrow points to a vertical pink line within the middle grey layer. A text box next to the arrow contains the text: "Use bolts here to make repair on insulation easy".</p>		

For å legge til flere linjer: Plasser kursor i nedre høyre celle, under "Tid/Date", og trykk på tab-knappen.
To add more lines: Place cursor in lower right hand cell, below "Tid/Date", and press tab. (Delete this text when finished)

Møtedato / Date of meeting	Kl / Time	Sted / Location DRK	Nr / No
Prosjekt / Project DR exhaust case Test 5 Agenda / main issues: Review of mechanical properties of			
Møteleder / Meeting requested by	Referent / Minuted by	Dato / Date 07.03.14	
Deltakere / Participants DLY,			
Kopi til /Copy to			
Pkt / Item no	Referat / Minutes	Ansv. /Resp.	Tid /Date
01	REQUIREMENT no 21: It should be verified that the exhaust case system will handle the thermal stresses caused by longtime full load. Comments:		
02	REQUIREMENT no 22: It should be verified that the exhaust case system will handle the thermal stresses caused by transient condition. Comments:		

For å legge til flere linjer: Plasser kursor i nedre høyre celle, under "Tid/Date", og trykk på tab-knappen.
 To add more lines: Place cursor in lower right hand cell, below "Tid/Date", and press tab. (Delete this text when finished)

Møtedato / Date of meeting	Kl / Time	Sted / Location DRK	Nr / No
Prosjekt / Project DR exhaust case Test 6 Alignment procedure			
Møteleder / Meeting requested by DLY	Referent / Minuted by dly	Dato / Date 07.03.14	
Deltakere / Participants DLY,			
Kopi til /Copy to			
Pkt / Item no	Referat / Minutes	Ansv. /Resp.	Tid /Date
01	<p>REQUIREMENT no 25: It should be easy to do the alignment of the exhaust case for first time installment.</p> <p>Comments: Yes this should be easier with the adjustable legs.</p> <p>The legs need access through a hatch at each side. Do access check with model of alignment tool.</p>	OK	DLY / IHA
02	<p>REQUIREMENT no 2: It should be easy to do the alignment of the exhaust case at site.</p> <p>Comments: One important thing to remember is the access to the outer receiver ring and the gap between PT and exhaust case receiver ring.</p> <p>The in and out lifting of the alignment tool is not affected. With the new design exhaust case.</p>	OK	DLY / IHA
03	<p>REQUIREMENT no 3: Support system for the exhaust case should maintain alignment under all operations, including transient.</p> <p>Comments: New system with adjustable legs in all directions is ok, as long as the locking system for these legs eliminates the possibility for vibration wear in locking mechanism. The exhaust case will have 7 fixing points constraining it in all direction.</p> <p>4 Vertical 2 axial 1 radially fixation</p> <p>Old system was 4 vertical 1 fix point under case 1 rotation fixation</p> <p>The new system will provide thermal growth more in line with the turbine and be much easier to understand for field service rep.</p>	OK	DLY /I

For å legge til flere linjer: Plasser kursor i nedre høyre celle, under ”Tid/Date”, og trykk på tab-knappen.
To add more lines: Place cursor in lower right hand cell, below ”Tid/Date”, and press tab. (Delete this text when finished)

Møtedato / Date of meeting	Kl / Time	Sted / Location DRK	Nr / No
Prosjekt / Project DR exhaust case Test 7 HSE review			
Møteleder / Meeting requested by DLY	Referent / Minuted by	Dato / Date	
Deltakere / Participants DLY,			
Kopi til /Copy to			
Pkt / Item no	Referat / Minutes	Ansv. /Resp.	Tid /Date
01	REQUIREMENT no 28: Maintain safety of personnel and eq during operation and service in regard to the rotating shaft. <u>Comments:</u> The HSE requirements regarding the rotating shaft will be met by the coupling guard approved in earlier design reviews.		
02	REQUIREMENT no 29: Maintain safety of personnel during operation and service in regard to hot "seal air" emissions. <u>Comments:</u> This is also done with the coupling guard, and the new ventilation system. For complete blowout of the inner PT seal the rear seal flex should rip apart causing no big / heavy objects to fly through the air injuring people, and vent the tunnel room.		
03	REQUIREMENT no 30: Maintain safety of personnel during operation and service in regard to hot surfaces. <u>Comments:</u> The outer surface needs to be below 60° C during operation this is the same as req 24 and can be taken out. Fulfilled with 24) But there could be places where there is danger of leakage through the insulation, and this may result in a hotter outer cladding. Check OK		
04	REQUIREMENT no 31: The exhaust system must be safe to handle during fabrication. <u>Comments:</u> There should be added lifting points and lifting GA to describe lifting and handling, this is too early in the project. Other than this No remarks made. OK		
05	REQUIREMENT no 32: The exhaust system must be safe to handle during installation.		

	<p><u>Comments:</u> There should be added lifting points and lifting GA to describe lifting and handling, this is too early in the project. Other than this No remarks made. OK</p>		
06	<p>REQUIREMENT no 33: The exhaust system must be safe to handle during alignment.</p> <p><u>Comments:</u> There should be added lifting points and lifting GA to describe lifting and handling, this is too early in the project. Other than this No remarks made. OK</p>		
07	<p>REQUIREMENT no 34: The exhaust system must be safe to handle during transport.</p> <p><u>Comments:</u> We cannot see any particular issues with transport. This should be safer and easier to transport. Does not need lifting I put of the straight flange for transport. This greatly increases the ease of transport and workshop handling of the complete unites.</p>		
08	<p>REQUIREMENT no 17: Sound levels outside the package should not be higher than DR spec. Usually around xx dB or dBA.</p> <p><u>Comments:</u> There are no time to do any specific calculation on this. It is suggested that the insulation should be OK, if the insulation build up in the exhaust case is better than the silencer insulation build up from Camfill for the pn1041 MSP project.</p>		
09	<p>REQUIREMENT no 9: The exhaust system must lead the exhaust gases out of the enclosure in a safe way.</p> <p><u>Comments:</u> OK Bellow / flex and exhaust stack above the case is project specific and should be detailed later.</p>		
10	<p>REQUIREMENT no 19: The system has to meet all of DR and customer defined HSE requirements.</p> <p><u>Comments:</u> We have done a virtual workaround of the model and cant at this stage see, any HSE related problems that could stop the further development of the case. There are more detailing to do on the model. As there are a lot of details that are missing yet. But is should be able to go out in the marked and ask about the interest for this product. Model could be released to Øyvind and DR with as many details ass possibly implemented the week of Presentation preparation.</p>		

For å legge til flere linjer: Plasser kursor i nedre høyre celle, under "Tid/Date", og trykk på tab-knappen.

To add more lines: Place cursor in lower right hand cell, below "Tid/Date", and press tab. (Delete this text when finished)

TIME SHEET

WEEK 05: 1/27/2014 – 2/2/2014

DRESSER-RAND

[Company Slogan]

[Street Address]

[City, ST ZIP Code]

[Phone Number]

[Fax Number]

EMPLOYEE NAME: LYBEK, DAVID (KBG)	TITLE: ENGINEER
EMPLOYEE NUMBER: NA	STATUS: GOOD
DEPARTMENT: NA	SUPERVISOR: ØVIND EIDSMOEN

DATE	START TIME	END TIME	DESCRIPTION	HOURS	TOTAL HOURS
1/28/2014	0900	2100	First meting 0900-1500 discussing the project execution. Homework 1600-2100. Establish MOM Establish time sheet. Find project planning tool, Manage project	11	11
1/29/2014	0900	1200	Preparation for first Veilednings møte	3	14
1/29/2014	1200	1330	Veilednings møte	1,5	15,5
1/29/2014	1330	1800	Etterarbeid Veilednings møte	4,5	20
1/30/2014	0900	1200	Discussion on way forward.	3	23
1/30/2014	1200	1600	Find project collaboration tool (at home)	4	27
1/31/2014	1000	1600	First meeting with client	4	31
1/31/2014	1600	2100	Work after client meeting	5	36
[Pick the date]					
[Pick the date]					
[Pick the date]					
WEEKLY TOTALS:				THIS WEEK 36	TOTAL 36

EMPLOYEE SIGNATURE:	DATE: [PICK THE DATE]
SUPERVISOR SIGNATURE:	DATE: [PICK THE DATE]

TIME SHEET

WEEK 06: 2/3/2014 – 2/9/2014

DRESSER-RAND

[Company Slogan]

[Street Address]
[City, ST ZIP Code]
[Phone Number]
[Fax Number]

EMPLOYEE NAME: LYBEK, DAVID (KBG)	TITLE: ENGINEER
EMPLOYEE NUMBER: NA	STATUS: GOOD
DEPARTMENT: NA	SUPERVISOR: ØVIND EIDSMOEN

DATE	START TIME	END TIME	DESCRIPTION	HOURS	TOTAL HOURS
2/4/2014	0800	0900	Travel Kongsberg- Drammen	1	1
2/4/2014	0900	1500	Visit client in Drammen Workshop	6	7
2/4/2014	1200	1600	Omvisning	Included in task above	
2/4/2014	1600	1700	Personlige notater	1	8
2/3/2014	1700	1800	Travel Drammen -Kongsberg	1	9
2/3/2014	1600	0000	Risiko analyse	8	17
2/5/2014	0800	1500	Start to spec. Read and understand the requirements from DR	7	24
2/6/2014	1000	1200	Pre meeting for veiledning	2	26
2/6/2014	1200	-	Emergency in Drammen work shop	NA	
2/9/2014	1200	2300	Read and understand specs	11	37
2/12/2014					
[Pick the date]					
[Pick the date]					
WEEKLY TOTALS:				37	ACCUMULATED TOTAL 73

EMPLOYEE SIGNATURE:	DATE: [PICK THE DATE]
SUPERVISOR SIGNATURE:	DATE: [PICK THE DATE]

TIME SHEET

WEEK 07: 2/10/2014 – 2/16/2014

DRESSER-RAND

[Company Slogan]

[Street Address]
[City, ST ZIP Code]
[Phone Number]
[Fax Number]

EMPLOYEE NAME: LYBEK, DAVID (KBG)	TITLE: ENGINEER
EMPLOYEE NUMBER: NA	STATUS: OK
DEPARTMENT: NA	SUPERVISOR: ØVIND EIDSMOEN

DATE	START TIME	END TIME	DESCRIPTION	HOURS	TOTAL HOURS
2/12/2014	0700	1000	Computer and network trouble	3	3
2/12/2014	1000	1200	Going through mom from last time	2	5
2/12/2014	1200	1300	Veiledning møte	1	6
2/12/2014	1300	1600	Writing mom from meeting	2	8
2/13/2014	1200	1500	Small meeting reg progress	3	11
2/14/2014	1200	0300	First milestone	15	26
2/15/2014	1200	0300	First milestone	15	41
2/16/2014	1200	0300	First milestone	15	56
[Pick the date]					
[Pick the date]					
WEEKLY TOTALS:				56	ACCUMULATED TOTAL 129

EMPLOYEE SIGNATURE:	DATE: [PICK THE DATE]
SUPERVISOR SIGNATURE:	DATE: [PICK THE DATE]

TIME SHEET

WEEK 08: 2/17/2014 – 2/23/2014

DRESSER-RAND

[Company Slogan]

[Street Address]
 [City, ST ZIP Code]
 [Phone Number]
 [Fax Number]

EMPLOYEE NAME: LYBEK, DAVID (KBG)	TITLE: ENGINEER
EMPLOYEE NUMBER: NA	STATUS: BAD
DEPARTMENT: NA	SUPERVISOR: ØVIND EIDSMOEN

DATE	START TIME	END TIME	REGULAR HOURS	OVERTIME HOURS	TOTAL HOURS
2/17/2014	1000	0200	First milestone Prep rev 001 of main documents	16	16
2/18/2014	1000	0200	First milestone Prep rev 001 of main documents	16	32
2/19/2014	0900	0300	First milestone Prep rev 001 of main documents	18	50
2/20/2014	1200	0000	First milestone Prep rev 001 of main documents	12	62
2/21/2014	0900	1200	First milestone Prep of presentation	3	65
2/21/2014	1200	1500	After work FM	3	67
2/9/2014					
2/12/2014					
[Pick the date]					
[Pick the date]					
WEEKLY TOTALS:				67	ACCUMULATED TOTAL 196

EMPLOYEE SIGNATURE:	DATE: [PICK THE DATE]
SUPERVISOR SIGNATURE:	DATE: [PICK THE DATE]

TIME SHEET

WEEK 09: 2/24/2014 – 3/2/2014

DRESSER-RAND
[Company Slogan]

[Street Address]
[City, ST ZIP Code]
[Phone Number]
[Fax Number]

EMPLOYEE NAME: LYBEK, DAVID (KBG)	TITLE: ENGINEER
EMPLOYEE NUMBER: NA	STATUS: OK
DEPARTMENT: NA	SUPERVISOR: ØVIND EIDSMOEN

DATE	START TIME	END TIME	REGULAR HOURS	OVERTIME HOURS	TOTAL HOURS
2/24/2014	syk	syk	syk	.	7,5
2/25/2014	syk	syk	syk	-	15
2/26/2014	syk	syk	Veilednings møte uten DL til stede. syk	-	22,5
2/27/2014	syk	syk	syk	-	30
2/28/2014	1200	1500	Drøftinger etter første milepæl	3	33
2/6/2014					
2/9/2014					
2/12/2014					
[Pick the date]					
[Pick the date]					
WEEKLY TOTALS:				3	ACCUMULATED TOTAL 229

EMPLOYEE SIGNATURE:	DATE: [PICK THE DATE]
SUPERVISOR SIGNATURE:	DATE: [PICK THE DATE]

TIME SHEET

WEEK 10: 3/3/2014 – 3/9/2014

DRESSER-RAND
[Company Slogan]

[Street Address]
 [City, ST ZIP Code]
 [Phone Number]
 [Fax Number]

EMPLOYEE NAME: LYBEK, DAVID (KBG)	TITLE: ENGINEER
EMPLOYEE NUMBER: NA	STATUS: GOOD
DEPARTMENT: NA	SUPERVISOR: ØVIND EIDSMOEN

DATE	START TIME	END TIME	DESCRIPTION	HOURS	TOTAL HOURS
3/5/2014	0800	1200	Forberedelse til veilednings møte	4	4
3/5/2014	1200	1300	Veilednings møte uten GN	1	5
3/5/2014	1300	1800	Etterarbeid etter veilednings møte	5	10
3/7/2014	0800	0900	Transport Kongsberg -Drammen	1	11
3/7/2014	0900	1300	Forberedelse- møte med GN ang, veien videre etter VL-møte og første milepæl	4	15
3/7/2014	1300	1700	Møte med GN ang veien videre etter første milepæl	4	19
3/7/2014	1700	1800	Transport Drammen -Kongsberg	1	20
[Pick the date]					
[Pick the date]					
[Pick the date]					
WEEKLY TOTALS:				20	ACCUMULATED TOTAL 249

EMPLOYEE SIGNATURE:	DATE: [PICK THE DATE]
SUPERVISOR SIGNATURE:	DATE: [PICK THE DATE]

TIME SHEET

WEEK NO 11: 3/10/2014 – 3/16/2014

DRESSER-RAND

[Company Slogan]

[Street Address]
[City, ST ZIP Code]
[Phone Number]
[Fax Number]

EMPLOYEE NAME: LYBEK, DAVID (KBG)	TITLE: ENGINEER
EMPLOYEE NUMBER: NA	STATUS: OK
DEPARTMENT: NA	SUPERVISOR: ØVIND EIDSMOEN

DATE	START TIME	END TIME	DESCRIPTION	HOURS	TOTAL HOURS
3/13/2014	1100	1200	Transport Kongsberg- Drammen	1	1
3/13/2014	1200	1600	Gjennomgang av hva som skulle hvert gjort og hvordan det skal gjøres. Med GN.	4	5
3/13/2014	1700	1800	Transport Drammen - Kongsberg	1	6
3/14/2014	1000	1100	Transport Kongsberg- Drammen	1	7
3/14/2014	1200	1530	Mere Gjennomgang av hva som skulle hvert gjort og hvordan det skal gjøres.	4,5	11,5
2/13/2014	1530	1630	Transport Drammen - Kongsberg	1	12,5
[Pick the date]					
[Pick the date]					
[Pick the date]					
[Pick the date]					
WEEKLY TOTALS:				12,5	ACCUMULATED TOTAL 261,5

EMPLOYEE SIGNATURE:	DATE: [PICK THE DATE]
SUPERVISOR SIGNATURE:	DATE: [PICK THE DATE]

TIME SHEET

WEEK NO 12: 3/17/2014 – 3/23/2014

DRESSER-RAND

[Company Slogan]

[Street Address]
[City, ST ZIP Code]
[Phone Number]
[Fax Number]

EMPLOYEE NAME: LYBEK, DAVID (KBG)	TITLE: ENGINEER
EMPLOYEE NUMBER: NA	STATUS: NOT OK
DEPARTMENT: NA	SUPERVISOR: ØVIND EIDSMOEN

DATE	START TIME	END TIME	DESCRIPTION	HOURS	TOTAL HOURS
3/19/2014	0900	1200	Forberedelse veilednings møte	3	3
3/19/2014	1200	1300	Veilednings møte hvor det blir presisert av DL og FH at det er for liten framgang	1	4
3/19/2014	1300	1500	Etter arbeid veilednings møte, mest drøfting om hva som skulle hvert gjort og hvordan dette skal gjøres	2	6
3/21/2014	1200	1300	Transport Kongsberg- Drammen	1	7
3/21/2014	1300	1330	GN ikke møtt opp som avtalt var på biblioteket som avtalt men han var ikke der.	0,5	7,5
2/21/2014	1530	1630	Transport Drammen – Kongsberg	1	8,5
[Pick the date]					
[Pick the date]					
[Pick the date]					
[Pick the date]					
WEEKLY TOTALS:				8,5	ACCUMULATED TOTAL 270

EMPLOYEE SIGNATURE:	DATE: [PICK THE DATE]
SUPERVISOR SIGNATURE:	DATE: [PICK THE DATE]

TIME SHEET

WEEK NO 13: 3/24/2014 – 3/30/2014

DRESSER-RAND
[Company Slogan]

[Street Address]
[City, ST ZIP Code]
[Phone Number]
[Fax Number]

EMPLOYEE NAME: LYBEK, DAVID (KBG)	TITLE: ENGINEER
EMPLOYEE NUMBER: NA	STATUS: NOT OK
DEPARTMENT: NA	SUPERVISOR: ØVIND EIDSMOEN

DATE	START TIME	END TIME	DESCRIPTION	HOURS	TOTAL HOURS
3/26/2014	1200	1300	Lest mail	1	1
3/27/2014	1100	1300	Sett etter progress, (finner ingen)	2	3
[Pick the date]					
[Pick the date]					
[Pick the date]					
[Pick the date]					
[Pick the date]					
[Pick the date]					
[Pick the date]					
[Pick the date]					
WEEKLY TOTALS:				3	ACCUMULATED TOTAL 273

EMPLOYEE SIGNATURE:	DATE: [PICK THE DATE]
SUPERVISOR SIGNATURE:	DATE: [PICK THE DATE]

TIME SHEET

WEEK NO 14: 3/31/2014 – 4/6/2014

DRESSER-RAND

[Company Slogan]

[Street Address]
[City, ST ZIP Code]
[Phone Number]
[Fax Number]

EMPLOYEE NAME: LYBEK, DAVID (KBG)	TITLE: ENGINEER
EMPLOYEE NUMBER: NA	STATUS: BAD
DEPARTMENT: NA	SUPERVISOR: ØVIND EIDSMOEN

DATE	START	END	DESCRIPTION	HOURS	TOTAL HOURS
4/1/2014	1200	1300	Lest igjennom hva GN har levert for å finne progress. Ingen progress funnet.	1	1
4/2/2014	0800	1200	Forberedelse til VL møte sett igjennom dokumentasjon for å finne lyspunkter, og finner ingen. Rev 002 av prosjekt plan er ikke fullført på ca 1 md. Det eneste som skulle være med i rev 002 var en diskusjon av prosjekt modellen vår.	4	5
4/2/2014	1200	1330	Veilednings møte hvor det blir presisert av DL og FH at progress ikke er tilfredsstillende, og at dette setter prosjektet i fare. Det er høy temp i møte og uenighet mellom DL og GN om hva som er status. GN sier tilslutt at han trekker seg fra oppgaven.	1,5	6,5
4/2/2014	1330	1700	DL forklarer GN hvordan vi kan redde prosjektet og komme oss igjennom andre milepæl. GN får i oppgave å gjøre sende ut utkastet han har og å gjøre det ferdig dette til 3-4 April.	3,5	10
4/3/2014	1000	1100	GN ringer for å si at han har tenkt seg om å ikke vill være med mere, han sier at han vill heller prøve på nytt til neste år.	1	11
4/3/2014	1100	1300	<u>TEST 1 PREPARATION</u> TASK 1002 PLANNING -hva skal gjøres -	2	13
4/3/2014	1300	0100	<u>TEST 1 PREPARATION</u> TASK 1003 CONSTRUCTION -hva er de store problemene. -hvordan kan de konseptuelt løses -hånd kalkulasjoner	12	25
4/5/2014	0900	0000	<u>TEST 1 PREPARATION</u> TASK 1004 REALIZATION -modellering av / til test 1	15	40
4/6/2014	0900	0000	<u>TEST 1 PREPARATION</u> TASK 1004 REALIZATION -modellering av / til test 1	15	55

[Pick the date]					
WEEKLY TOTALS:				55	ACCUMULATED TOTAL 328

EMPLOYEE SIGNATURE:	DATE: [PICK THE DATE]
SUPERVISOR SIGNATURE:	DATE: [PICK THE DATE]

TIME SHEET

WEEK NO 16: 4/14/2014 – 4/20/2014

DRESSER-RAND
[Company Slogan]

[Street Address]
[City, ST ZIP Code]
[Phone Number]
[Fax Number]

EMPLOYEE NAME: LYBEK, DAVID (KBG)	TITLE: ENGINEER
EMPLOYEE NUMBER: NA	STATUS: NOT OK
DEPARTMENT: NA	SUPERVISOR: ØVIND EIDSMOEN

DATE	START TIME	END TIME	DESCRIPTION	HOURS	TOTAL HOURS
4/7/2014	1200	1400	Gjort enden notater etter andre framføring	2	2
3/27/2014	ferie	ferie			
[Pick the date]	ferie	ferie			
[Pick the date]	helligdag				
[Pick the date]	helligdag				
[Pick the date]	helligdag				
[Pick the date]					
[Pick the date]					
[Pick the date]					
[Pick the date]					
WEEKLY TOTALS:				2	ACCUMULATED TOTAL 391

EMPLOYEE SIGNATURE:	DATE: [PICK THE DATE]
SUPERVISOR SIGNATURE:	DATE: [PICK THE DATE]

TIME SHEET

WEEK NO 15: 4/7/2014 – 4/13/2014

DRESSER-RAND

[Company Slogan]

[Street Address]
[City, ST ZIP Code]
[Phone Number]
[Fax Number]

EMPLOYEE NAME: LYBEK, DAVID (KBG)	TITLE: ENGINEER
EMPLOYEE NUMBER: NA	STATUS: NOT OK
DEPARTMENT: NA	SUPERVISOR: ØVIND EIDSMOEN

DATE	START	END	DESCRIPTION	HOURS	TOTAL HOURS
4/7/2014	0800	1200	<u>TEST 1 PREPARATION</u> TASK 1002 PLANNING -hvordan skal testen foregå	4	4
4/7/2014	1200	1500	Meeting with GN to explain what needs to be done for 2 milestones. Explained that the relevant documents needed to be delivered late today or early tomorrow. He said OK but did not take any actions to get the relevant docs in a deliverable state.	3	7
4/7/2014	1500	1800	<u>TEST 1</u> TASK 1005 TEST -output-released mom -output- approval of model	3	10
4/7/2014	1800	1900	<u>TEST 1</u> TASK 1006 RELEASE -småkommentarer ingenting stort -alt er rettet på -OK	3	13
4/7/2014	1900	2000	<u>TEST 1</u> TASK 1007 ANALYSES -can't see anything mechanical, that will have a devastating effect on project	1	14
4/7/2014	2000	2030	<u>TEST 1</u> TASK 1008 PROJECT MGR. -ingen tid til å tenke, nøye igjennom Prosjektet med tanke på forandringer. Rekker ikke dette nå får neste milepæl 10.apr	0,5	14,5
4/7/2014	2030	2100	<u>TEST 1</u> TASK 1009 OTHER -ingen tid til å tenke nøye igjennom alle	0,5	15

			sider ved prosjektet til neste milepæl		
4/8/2014	0700	1200	Preparation of rev 002 of the project plan. This is the discussion and explanation of the selection of project model. Wich was some of the remarks form the first milestone. This was agreed that GN should do this and be finished by 21.03.14 This should be done by GN during the last month but I have to do this NOW.	5	20
4/8/2014	1200	1500	Hatt møte med GN om framdrift og hva som skal gjøres og hvordan det skal gjøres. Det er kommuniser til GN at REV 002 av prosjekt planen må leveres i dag, ellers blir vi tregt i karakter. Dette utløste ingen handling fra GN. Det er ikke tatt med noe for å kopiere in CD eller perm eller papir så dokumentet kunne skrives ut og leveres. Han stiller seg utaførstående til at dette er hans ansvar at blir utført. Han forventer at alle andre skal gjøre noe og være ferdig med sitt men han gjør aldri noe ferdig. Dette stjeler uhyre kritisk tid fra meg som er 100% uproduktiv. Kunne like gjerne sett på TV i disse 3 timene, utbytte for gruppa hadde vært like stort.	3	23
4/8/2014	1500	0300	Preparation of rev 002 of the project plan. This is the discussion and explanation of the selection of project model. Which was some of the remarks form the first milestone. This was agreed that GN should do this and be finished by 21.03.14 This should be done by GN during the last month but I have to do this NOW.	12	35
4/9/2014	0700	1100	Preparation of rev 002 of the project plan. This is the discussion and explanation of the selection of project model. Which was some of the remarks form the first milestone. This was agreed that GN should do this and be finished by 21.03.14 This should be done by GN during the last month but I have to do this NOW.	4	39
4/9/2014	1200	1500	Forberedelse av 2 milepæl. Kopierte ut dokumenter og lagt i permer. Sortert og ordnet med formatering. Skulle få sendt over et utkast fra GN på Hibu men det kom aldri. Er derfor nødt til å dra bort (på hibu) å få dette fysisk kopiert over på min Minne pinne / PC.	3	42
4/9/2014	1500	1600	Henter rev 002 av prosjekt plan på hibu fra GN. Da denne ikke blir sendt, for printing og levering.	1	43
4/9/2014	1700	0300	Formatering, retting og printing av rev 002 prosjekt plan.	10	53
4/10/2014	0700	1400	Jobbet med Power Point presentasjon Integrere GN sine slides inn i PPT Trene på framføring	7	60
4/10/2014	1400	1420	Presentasjon av 2 milepæl.	0,33	60,33
4/10/2014	1420	1500	Etter-møte og samtaler	0,66	61
[Pick the date]					
[Pick the date]					
WEEKLY TOTALS:				61	ACCUMULATED TOTAL 389

EMPLOYEE SIGNATURE:	DATE: [PICK THE DATE]
SUPERVISOR SIGNATURE:	DATE: [PICK THE DATE]

TIME SHEET

WEEK NO 17: 4/21/2014 – 4/27/2014

DRESSER-RAND
[Company Slogan]

[Street Address]
[City, ST ZIP Code]
[Phone Number]
[Fax Number]

EMPLOYEE NAME: LYBEK, DAVID (KBG)	TITLE: ENGINEER
EMPLOYEE NUMBER: NA	STATUS: NOT OK
DEPARTMENT: NA	SUPERVISOR: ØVIND EIDSMOEN

DATE	START TIME	END TIME	DESCRIPTION	HOURS	TOTAL HOURS
4/21/2014	helligdag				
4/22/2014	0900	1500	<u>TEST 2 PREPARATION</u> TASK 1002 PLANNING -hva skal gjøres for å løse test 2 -	6	6
4/23/2014	1000	1600	<u>TEST 2 PREPARATION</u> TASK 1003 CONSTRUCTION Req 5 houses from back of turbine is safe OK Req 6 preasure could be same as turbine enclosure preasure equalisation could be OK	6	12
4/24/2014	0900	1500	<u>TEST 2 PREPARATION</u> TASK 1003 CONSTRUCTION Req 16 chech access with 3d dummy will be OK	6	18
4/25/2014	0900	1500	<u>TEST 2 PREPARATION</u> TASK 1003 CONSTRUCTION Req 18 diffusor geometry model in to 3d OK	6	24
4/26/2014	0900	1500	Write rev 003 projeckt plan	6	30
4/27/2014	1200	1800	Write rev 003 projeckt plan	6	36
[Pick the date]					
[Pick the date]					
[Pick the date]					

WEEKLY TOTALS:		36	ACCUMULATED TOTAL 427
-----------------------	--	-----------	----------------------------------

EMPLOYEE SIGNATURE:	DATE: [PICK THE DATE]
SUPERVISOR SIGNATURE:	DATE: [PICK THE DATE]

TIME SHEET

WEEK NO 18: 4/28/2014 – 5/4/2014

DRESSER-RAND

[Company Slogan]

[Street Address]

[City, ST ZIP Code]

[Phone Number]

[Fax Number]

EMPLOYEE NAME: LYBEK, DAVID (KBG)	TITLE: ENGINEER
EMPLOYEE NUMBER: NA	STATUS: NOT OK
DEPARTMENT: NA	SUPERVISOR: ØVIND EIDSMOEN

DATE	START TIME	END TIME	DESCRIPTION	HOURS	TOTAL HOURS
4/28/2014	1200	1500	Svart på mail og div prosjekt relatert dokument arbeid i forbindelse med innkalling til veiledermåte	3	3
4/29/2014	0900	1500	<u>TEST 2 PREPARATION</u> TASK 1004 REALIZATION -modellering av 3d modell til test 2 -	6	9
4/30/2014	1000	1200	<u>TEST 2 PREPARATION</u> TASK 1004 REALIZATION -modellering av 3d modell til test 2	6	12
4/30/2014	1200	1300	Veiledningsmøte med FH Det ble gjennomgått MOM fra forvegang og presisert fra DL og FH at MOM refekterte ikke forgie møte, men forgie framføring. Dette er ikke rettet opp fra forge gang enda det har blitt lest og kommentert manglemdne før disse ble sendt inn til FH. Oppfølgingsdokumentet er ikke oppfulgt etter kommentarer fra FH fra forgie gang og kommentarer fra DL før innsendelse. DL er i en håpløs situasjonmed hensyn til organisering og oppfølging.	1	13
4/30/2014	1300	1500	Oppfølgings samtaler med GN hvor det går igjennom hva som sakl kje til neste gang. Han sier han skal jobbe med Web side og Plakat. Og han får kommentar på at han må bestille et møte med DR.	1	14
5/1/2014	0900	2100	<u>TEST 2 PREPARATION</u> TASK 1004 REALIZATION -modellering av 3d modell til test 2	12	26

5/2/2014	0900	1800	<u>TEST 2 PREPARATION</u> TASK 1004 REALIZATION -modellering av 3d modell til test 2	12	38
5/3/2014	0900	1900	<u>TEST 6 PREPARATION</u> TASK 1003 CONSTRUCTION Req 25 , 26 and 27 Looked at a new way to secure the inner lining of exhaust case. That is necessary to align the case without access to the bottom of the case.	11	49
[Pick the date]					
[Pick the date]					
[Pick the date]					
[Pick the date]					
[Pick the date]					
WEEKLY TOTALS:				49	ACCUMULATED TOTAL 476

EMPLOYEE SIGNATURE:	DATE: [PICK THE DATE]
SUPERVISOR SIGNATURE:	DATE: [PICK THE DATE]

TIME SHEET

WEEK NO 19: 5/5/2014 – 5/11/2014

DRESSER-RAND
[Company Slogan]

[Street Address]
[City, ST ZIP Code]
[Phone Number]
[Fax Number]

EMPLOYEE NAME: LYBEK, DAVID (KBG)	TITLE: ENGINEER
EMPLOYEE NUMBER: NA	STATUS: NOT OK
DEPARTMENT: NA	SUPERVISOR: ØVIND EIDSMOEN

DATE	START TIME	END TIME	DESCRIPTION	HOURS	TOTAL HOURS
5/5/2014	0900	1000	Mat på GN om at han må booke møte med DR.	1	1
5/5/2014	0900	1700	<u>TEST 3 PREPARATION</u> TASK 1003 CONSTRUCTION Req 7, 8 24 and 24-Calculated surface temp of outside of enclosure. This resulted in a heat flow of ca 400W/m ² . 7-Oil to be led to drip tray. Preasure and flow in the coupling guard to be looked at alter.	8	9
5/6/2014	0800	2000	<u>TEST 3 PREPARATION</u> TASK 1003 CONSTRUCTION Req 8 investigated air leak from back of PT and it is nominaly 0. And when turbine is new this is the case but after some time the wear of the piston ring causes hot PT gasses to pas the sealing and entering the atmosphere in the back of the turbin.	12	21
5/7/2014	0900	1230	Prepare for meeting with DR. I need to book meeting room because GN has forgooten this. GN has not askt for nor prepared a Agenda for the meeting.	3	24
5/7/2014	1230	1400	Meeting with DR. Meeting set with SYT and ØE. GN is aksed for a agenda but he has not repaired one. His response is "good question". I haver to take the lead and tell them where we are with the prosjekt and what we intend to do the last weeks.	1,5	25,5
5/7/2014	1400	1500	Discuss with GN what he has done from last time, and it appers that Web page he has	1	26,5

			started on is on a free public server. This indicates that he has not read the information on fronter. To nexty time (Monday his task is to get the web page finiched.)		
5/8/2014	0900	2000	<u>TEST 2 PREPARATION</u> TASK 1004 REALIZATION -modellering av 3d modell til test 2	11	37.5
5/9/2014	0900	1700	Modeled a new fastening system based on the experiance with model.	8	45.5
[Pick the date]					
[Pick the date]					
WEEKLY TOTALS:				45.5	ACCUMULATED TOTAL 521,5

EMPLOYEE SIGNATURE:	DATE: [PICK THE DATE]
SUPERVISOR SIGNATURE:	DATE: [PICK THE DATE]

TIME SHEET

WEEK NO 20: 5/12/2014 – 5/18/2014

DRESSER-RAND
[Company Slogan]

[Street Address]
[City, ST ZIP Code]
[Phone Number]
[Fax Number]

EMPLOYEE NAME: LYBEK, DAVID (KBG)	TITLE: ENGINEER
EMPLOYEE NUMBER: NA	STATUS: NOT OK
DEPARTMENT: NA	SUPERVISOR: ØVIND EIDSMOEN

DATE	START TIME	END TIME	DESCRIPTION	HOURS	TOTAL HOURS
5/12/2014	0900	1200	Modelling for test 2	3	3
5/12/2014	1200	1500	DL is working on Prepare revision of test plan at HIBU. GN Web side ikke startet på, og han kommer ikke videre på denne akkurat nå. Han Vet heller ikke når denne skal være ferdig skal skrive på prosjekt planen rev 03 etter hans opplysning.	xx	xx
5/12/2014	1500	2000	Preparing for tes	12	21
5/7/2014	0900	1230	Preparing for test	3	24
5/7/2014	1230	1400	Meeting with DR. Meeting set with SYT and ØE. GN is aksed for a agenda but he has not repared one. His response is "good question". I haver to take the lead and tell them where we are with the prosjekt and what we intend to do the last weeks.	1,5	25,5
5/7/2014	1400	1500	Discuss with GN what he has done from last time, and it appers that Web page he has started on is on a free public server. This indicates that he has not read the information on fronter. To nexty time (Monday his task is to get the web page finiched.)	1	26,5
5/8/2014	0900	2000	<u>TEST 2 PREPARATION</u> TASK 1004 REALIZATION -modellering av 3d modell til test 2	11	37,5
5/9/2014	0900	1700	Modeled a new fastening system based on the experiance with model.	8	45,5
[Pick the date]					

[Pick the date]					
WEEKLY TOTALS:				45,5	ACCUMULATED TOTAL 521,5

EMPLOYEE SIGNATURE:	DATE: [PICK THE DATE]
SUPERVISOR SIGNATURE:	DATE: [PICK THE DATE]

Establish

Timesheet- Use spreadsheet or similar from web ne

MOM- use DR one

To next time

we need to confirm project tool -DLY and GN

book time with extern editor for presentation done need confirmation DLY

book time with external editor for first meeting about spec. NEED to be done asap

First mile stone

sent mail to confirm 21.02.14 kl 1100-1300 time date and place to moholth@gmail.com

Dette skal skje:

2 fulle ARBEIDSDager før presentasjonen - dokumentasjonen skal leveres

30 minutter før presentasjonen - formøte, intern og ekstern veileder og sensor

Presentasjonen - MAX 20 minutter

Mulig utspørring

Ettermøte

Dokumentasjonen MÅ på dette tidspunktet inneholde en versjon av:

Kravspec:

Main focus ASAP we need to get this going, so we have a workable and believable spec to the presentation 21.02.14 Godwin to start with 15 requirements to first meeting with Frank H to Wednesday 29.01.14. -Based on the short summary of the project given by Dresser-Rand.

Group need to have first meeting with Dresser-rand ASAP to get the whole picture of specification. DLY to contact Øivind Eidsmoen to get progress.

Testspec

Will be bases on the specification.

Prosjektplan:

DLY to write a general plan for time the project, to include base load 7,5t tirs, tors and one weekend day. And half of Wednesday including .

Møtedato / Date of meeting 07.3.14	Kl / Time 1200-1500	Sted / Location Drammen bibliotek	Nr / No
Prosjekt / Project DR exhaust case			
Møteleder / Meeting requested by DLY	Referent / Minuted by dly	Dato / Date 07.03.14	
Deltakere / Participants DLY, GN			
Kopi til /Copy to			
Pkt / Item no	Referat / Minutes	Ansv. /Resp.	Tid /Date
01	Gjennomgang av frammgang for GN.	info	
02	Det diskuteres prosjekt mal. Det er uenighet om hvilken som skal brukes. GN sin eller opprinelig. Det blir tilslutt enighet om at den orginale skal gjelde.	info	
03	Innholdet til det GN har drodusert og det blir påpekt en del mangler det gås igje igjennom orginal plan for å få en forståelse av hvordan dette kan gjøres på en rasjonel måte. GN tar lead på denne task og den skal være ferdig til 21.03.	GN	21.03.14

For å legge til flere linjer: Plasser kursor i nedre høyre celle, under "Tid/Date", og trykk på tab-knappen.

To add more lines: Place cursor in lower right hand cell, below "Tid/Date", and press tab. (Delete this text when finished)



Møtedato / Date of meeting 07.05.14	Kl / Time 1230-14	Sted / Location DR at Troll meetinroom	Nr / No
Prosjekt / Project DR exhaust case			
Møteleder / Meeting requested by GN	Referent / Minuted by GN but DLY writes this	Dato / Date 07.05.14	
Deltakere / Participants DLY, GN, Øivinf E, Svein Y J and Ivar Hagen			
Kopi til /Copy to NA			
Pkt / Item no	Referat / Minutes	Ansv. /Resp.	Tid /Date
01	GN har kalt inn til møte uten å bestille møte rom. Dette blev pressisert. DL ordnet møterom samme dag.		
02	GN har kalt in til møte uten, agenda. Dresser Rand etterspør dette. Dette har blitt kommunisert pr tlf at dette mangler.	GN	14.03
3	DLtar ordet å forteller hva som er modellert så langt, og vi går igjennom hva som kan		
	Test 2 blir nøe diskutert og flere problemer blir belyst. - - - - -		

For å legge til flere linjer: Plasser kursor i nedre høyre celle, under "Tid/Date", og trykk på tab-knappen.
To add more lines: Place cursor in lower right hand cell, below "Tid/Date", and press tab. (Delete this text when finished)

Møtedato / Date of meeting 07.05.14	Kl / Time 1230-14	Sted / Location DR at Troll meetinroom	Nr / No
Prosjekt / Project DR exhaust case			
Møteleder / Meeting requested by GN	Referent / Minuted by GN but DLY writes this	Dato / Date 07.05.14	
Deltakere / Participants DLY, GN, Øivinf E, Svein Y J and Ivar Hagen			
Kopi til /Copy to NA			
Pkt / Item no	Referat / Minutes	Ansv. /Resp.	Tid /Date
01	Møtes på hibu kl 1230 for prosjekt gjennomgang GN møter opp ca 1300		
02	.Han har fått i oppgave å gjøre ferdig Web siden for prosjektet til 07.05.14 dette er ikke begynt på.	GN	ASAP
3	GN blir fortalt at dette skulle være ferdig for lenge siden, og det blir presisert at det har gått 2 uker siden det skulle være ferdig, og at hvis hab holder samme tempo som nå så rekker han ikke å bli ferdig med denne til 26.05.14. Han blir da aggressiv og sier at han driter i det og vill sløyfe hele oppgaven med å lage web side.	INFO	
4	DL pusher på for å fået svar på hva som kan bli ferdig til i morgen tirsdag. Etter GN sin utsagn skal rev 03 av prosjekt planen være ferdig Onsdag 14.05.14.	GN	14.05.14
	DL pressiserer at det er masse arbeid som gjenosår så det hadde hvert fint om GN blir fedig med noe så DL kan få hjelp.		

For å legge til flere linjer: Plasser kursor i nedre høyre celle, under "Tid/Date", og trykk på tab-knappen.

To add more lines: Place cursor in lower right hand cell, below "Tid/Date", and press tab. (Delete this text when finished)

Møtedato / Date of meeting 26.05.14	Kl / Time 0900	Sted / Location Kongsberg	Nr / No
Prosjekt / Project DR exhaust case GN has signe out of HBV.			
Møteleder / Meeting requested by DLY	Referent / Minuted by dly	Dato / Date 25.05.14	
Deltakere / Participants DLY, GN			
Kopi til /Copy to			
Pkt / Item no	Referat / Minutes	Ansv. /Resp.	Tid /Date
01	Godwin Namor har meldt sin fratreden fra prosjektet pr mail.		
02	 Re dokument til levering.msg		
03	<p>GN opplyser en masse merkelige teorier på at jeg ikke liker ham. Og legger skylden på med for at han ikke har levert til prosjektet. Etter min mening er han ikke kvalifisert til å ta fatt på en avsluttende oppgave.</p> <p>Han mangler både grunnleggende kunnskap faglig og en total mangel på interesse og innsats.</p> <p>Det er synd at jeg må slite med en slik person gjennom det siste semestret.</p>		
03	<p>Han kommer i denne mail med mange beskyldninger igjenn.</p>  Re Kommentarer til prosjekt plan som skul		
	<p>Vi avtalte derette å møtes på frdagen fra 09000 til 1100 for å som han sier det gjøre det ferdig til leverin. Documentet han leverer er fullt av plagiat og det vill ta hele uka og rette det opp.</p> <p>Ref tidligere mail.</p> <p>Det han greier er å møteopp 1100. dette i inspurten av et prosjekt. Slik oppførsel tolereres ikke.</p>		

For å legge til flere linjer: Plasser kursor i nedre høyre celle, under "Tid/Date", og trykk på tab-knappen.
 To add more lines: Place cursor in lower right hand cell, below "Tid/Date", and press tab. (Delete this text when finished)

Møtedato / Date of meeting 27.01.14	Kl / Time 1000-1600	Sted / Location HIBU	Nr / No 001
Prosjekt / Project 15-Dresser Rand exhaust case			
Møteleder / Meeting requested by DLY	Referent / Minuted by DLY	Dato / Date 27.01.14	
Deltakere / Participants Godwin Narnor			
Kopi til /Copy to NA			
Pkt / Item no	Referat / Minutes	Ansv. /Resp.	Tid /Date
01	Establish Timesheet- Use spreadsheet or similar from web ne MOM- use DR one	DLY DLY	29.01.14 29.01.14
02	<p>Preliminary discussion First mile stone sent mail to confirm 21.02.14 kl 1100-1300 time date and place to moholth@gmail.com Dette skal skje: 2 fulle ARBEIDSdager før presentasjonen - dokumentasjonen skal leveres 30 minutter før presentasjonen - formøte, intern og ekstern veileder og sensor Presentasjonen - MAX 20 minutter Mulig utspørring Ettermøte</p> <p>Dokumentasjonen MÅ på dette tidspunktet inneholde en versjon av: Kravspec: Main focus ASAP we need to get this going, so we have a workable and believable spec to the presentation 21.02.14 Godwin to start with 15 requirements to first meeting with Frank H to Wednesday 29.01.14. -Based on the short summary of the project given by Dresser-Rand.</p> <p>Group need to have first meeting with Dresser-rand ASAP to get the whole picture of specification. DLY to contact Øivind Eidsmoen to get progress.</p> <p>Testspec Will be bases on the specification. Prosjektplan: DLY to write a general plan for time the project, to include base load 7,5t tirs, tors and one weekend day. And half of Wednesday including .</p>		
03	Write first draft of plan	DLY	03.02.14
04	To next time we need to confirm project tool -DLY and GN	GN	29.01.14
05	book time with extern editor for presentation done need confirmation	Dly	29.01.14
06	book time with external editor for first meeting about spec. NEED to be done asap	Dly	29.01.14
07	Godvin to write the first draft of spec about 15 requirements Must be done before meeting 29.01.14 so he gets up to speed on the project	GN	29.01.14

For å legge til flere linjer: Plasser kursor i nedre høyre celle, under "Tid/Date", og trykk på tab-knappen.

To add more lines: Place cursor in lower right hand cell, below "Tid/Date", and press tab. (Delete this text when finished)

Møtedato / Date of meeting 31.01.14	Kl / Time 1230-1500	Sted / Location DR Drammen	Nr / No 001
Prosjekt / Project 15			
Møteleder / Meeting requested by DLY	Referent / Minuted by DLY	Dato / Date 31.01.14	
Deltakere / Participants David Lybek, Godwin Narnor, Svein Ytreid Jacobsen, Øivind Edsmoen og Ivar Hagen			
Kopi til /Copy to NA			
Pkt / Item no	Referat / Minutes	Ansv. /Resp.	Tid /Date
01	Øivind Eidsmoen (ØE) gir en kort presentasjon av prosjektet	info	
02	Godwin N (GN) blir presentert for Svein Jacobsen (SYT) og Ivar Hagen (IHA)	info	
03	Det har blitt avtalt en inspeksjon asap på verkstedet i Drammen. Inspeksjon holdes på mandag 03.02.14.	DLY	03.02.14
04	Agenda blir orientert om – krav til eksoskasse. Det ble tatt utgangspunkt i orienteringen til ØE	info	
05	Hovedfokus vil nå være og sette opp kritiske krav til designet, men man må ikke glemme mindre kritiske krav.	DLY/ GN	19.02.14
06	Prosjekt modell har blitt diskutert og foreløpig ser det ut som en inkrementell modell er den mest hensiktsmessig DVS rev1 spec -> model -> review -> rev2 spec -> model -> review -> Dette har innvirkning på prosjekt plan.	DLY/ GN	19.02.14
07	Noen krav som ble diskutert. -Det må isoleres for lyd i eksos kasse. Tidligere ble dette tatt hånd om av enclosure. (isolasjon og oppbygning må undersøkes) -Built space (må bekreftes av DR) -transport space (må bekreftes av DR) -Start med Vectra 40G (40G) turbin. Denne maskinen blir utgangspunkt. 6000 o/min vanligst for direkte drift av kompressorer men kan brukes mot generator men da gjerne med gir boks for å redusere turtall. -tyngdepunkt på 40G er veldig nære enden av maskin. Dette gjør den vanskelig å løfte. (ta tak i inni pakka) -Ventilasjons luft bak kan være et problem og må undersøkes. Går det system luft ut til atmosfære bak. -koplings deksel er et viktig problem området. Lekkasje fra gir og kompressor kan være et problem spesielt hvis dette kan akkumuleres i isolasjonen. (brannfare) Lett overtrykk i koplings deksel for å opprettholde et hvis trykk på tetningene i tilstøtende utsyr, dette reduserer olje lekkasje. Eventuelt undersøke ytterligere krav med Tomaz S -innfesting av varm og kald side av kasse? Er utfordrende.		

08	Test vill kunne være oppfyllelse av krav. Dette kan i mange tilfeller være reviewer med oppdragsgiver.	Info	
09	Krav som kan begrense bruksområdet til eksos kassen kan dukke opp, og trenger ikke være til hinder for å løse oppgaven.	Info	

For å legge til flere linjer: Plasser kursor i nedre høyre celle, under "Tid/Date", og trykk på tab-knappen.
To add more lines: Place cursor in lower right hand cell, below "Tid/Date", and press tab. (Delete this text when finished)

Møtedato / Date of meeting		Kl / Time	Sted / Location	Nr / No
Prosjekt / Project				
Møteleder / Meeting requested by		Referent / Minuted by		Dato / Date
Deltakere / Participants				
Kopi til /Copy to				
Pkt / Item no	Referat / Minutes	Ansv. /Resp.	Tid /Date	
01	Vi tar en gjenl�mgang fra f�rste m�te. Godwin Informerer. - Info � E er ekster sensor - Send prosjekt kart til Intern veileder.-			
02	Vi g�r i gjennom forskjell kontrakt og spec p� og er mer eller mindre enige om at			
03	Spec FHE g�r igjennom spek krav. Se prosjekth�ndbok for krav tl kravspec.			
04	Se igjennom h�ndbok, Husk formelle krav			
05	.hva m� leveres og hvordan			
06	Ringperm farge fronter Med cd			
07	Timeliste med spesifisert aktivitet.			
08	Lag 2 sp�rsm�l til Frank som et eksempel p� framdrift under presangtasjonen.			
09	Test spec hva sier			

For   legge til flere linjer: Plasser kursor i nedre h yre celle, under "Tid/Date", og trykk p  tab-knappen.
To add more lines: Place cursor in lower right hand cell, below "Tid/Date", and press tab. (Delete this text when finished)

Møtedato / Date of meeting 29.01.14	Kl / Time 1200-1330	Sted / Location HBV	Nr / No 001
Prosjekt / Project First meeting with Frank			
Møteleder / Meeting requested by DLY	Referent / Minuted by DLY	Dato / Date 29.01.14	
Deltakere / Participants David L. Godwin N Frank H			
Kopi til /Copy to NA			
Pkt / Item no	Referat / Minutes	Ansv. /Resp.	Tid /Date
01	Frank mangler prosjekt beskrivelse	DLY	05.02.14
02	Mangler intern sensor går fram fra intern doc.	DLY	05.02.14
03	Til møte i morgen avklar språk.	Dly/GN	30.01.14
04	Skalering av prosjektet må tas opp med oppdragsgiver.	Dly/ GN	30.01.14
05	Frank forteller hva han forventer og foretrekker	info	
06	Vi går for fastsatt tid onsdag 1200-1300. for veiledning Sted er dette kontor (avtal med resepsjonen) D247 Husk å booke rom -Oppfølgings dokument se fronter dok. -Vi closer MOM på neste møte. -Avvik må beskriv. I forhold til plan. Og eventuelt. -agenda + eventuelt spørsmål.	DLY / GN	
07	Risiko vurderinger må gjøres for prosjekte og for eventuelt	DLY	asap
08	Husk evne til framdrift blir vurdert	info	
09	Etabler oppgave gjøres på torsdag sammen med DR	DLY / GN	30.01.14
10	Husk rettskriving og kosmetikk	info	
11	Les fronter dokument nøye	DLY / GN	30.1.14
12	Husk safty moment.	DLY / GN	
13	Sign contract with DR	DLY / GN	05.2.14
14	Det opplyses om første milepæl 21.02.14	info	

For å legge til flere linjer: Plasser kursor i nedre høyre celle, under "Tid/Date", og trykk på tab-knappen.

To add more lines: Place cursor in lower right hand cell, below "Tid/Date", and press tab. (Delete this text when finished)

Oppfølgingsdokument: W5

□ Gjennomgang av sist ukes jobb Godwin Narnor

- deltatt på første møte med oppdragsgiver
- vært på visning hos Dresser Rand Drammen.
- startet på krav spek

□ Gjennomgang av sist ukes jobb: David Lybek

- deltatt på første møte med oppdragsgiver
- vært på visning hos Dresser Rand Drammen.
- straks ferdig med risiko analyse av prosjektet.
- startet på krav spek.
- fungert som gruppeleder og skrevet de nødvendige dokumenter for å få start på prosjektet
- ordnet de nødvendige administrative aktiviteter.

□ Oversikt over hva som skal gjøres neste uke. Godwin Narnor

- prøve å få spec så omfattende at vi kan starte oppbygging av de andre aktivitetene til første milepæl

□ Oversikt over hva som skal gjøres neste uke. David Lybek

- prøve å få spec så omfattende at vi kan starte oppbygging av de andre aktivitetene til første milepæl

□ Kort oppsummering av selve prosjektet i forhold til prosjektplanen.

N/A -prosjekt plan foreligger ikke da krav spec ikke er tilstrekkelig ut arbeidet.

□ Oversikt som oppsummerer hvordan det går med kritiske aktiviteter.

Sliter med og organisere dokumenter på en fornuftig måte slik at de er tilgjengelige o
I riktig revisjon og oppdaterte.

Gruppen prøver og gjøre specen så fullstendig at vi kan begynne på di andre aktivitetene.

□ Legg ved:

timelistene til prosjektdeltakerne for siste uke.

Godwin Narnor -? have not recieved

David Lybek –OK

Oppfølgingsdokument: W6

□ Gjennomgang av sist ukes jobb Godwin Narnor

- veiledningsmøte
- started to look in to the spec
- started to plan presentation.

□ Gjennomgang av sist ukes jobb: David Lybek

- straks ferdig med risiko analyse av prosjektet.
- Risikoanalysen vill munne ut i konkrete tiltak for gruppen
- startet på krav spek.

□ Oversikt over hva som skal gjøres neste uke. Godwin Narnor

- prøve å få spec så omfattende at vi kan starte oppbygging av de andre aktivitetene til første milepæl
- Bør være ferdig til fredag
- så vi kan konsenterer oss om de andre dokumentene
- 1.-prosjekt plan
- 2.-Test plan
- Foreslår at vi møtes i Drammen for i løpet av helgen for å få sikret leveransen av første milepæl

□ Oversikt over hva som skal gjøres neste uke. David Lybek

- prøve å få spec så omfattende at vi kan starte oppbygging av de andre aktivitetene til første milepæl
- Bør være ferdig til fredag
- så vi kan konsenterer oss om de andre dokumentene
- 1.-prosjekt plan
- 2.-Test plan
- Foreslår at vi møtes i Drammen for i løpet av helgen for å få sikret leveransen av første milepæl

□ Kort oppsummering av selve prosjektet i forhold til prosjektplanen.

N/A -prosjekt plan foreligger ikke da krav spec ikke er tilstrekkelig ut arbeidet.

□ Oversikt som oppsummere hvordan det går med kritiske aktiviteter.

Sliter med og organisere dokumenter på en fornuftig måte slik at de er tilgjengelige o
I riktig revisjon og oppdaterte.

Gruppen prøver og gjøre specen så fullstendig at vi kan begynne på di andre aktivitetene.

□ Legg ved:

timelistene til prosjektdeltakerne for siste uke.

Godwin Narnor -? have not recieved

David Lybek



DL_Time
sheet_W07.docx

Mom last time



mom_veiledning_06_
02_14.docx

1

2

3

4

5

6

7

8

9

10

11

12

A

B

C

D

E

F

G

H

A

B

C

D

E

F

G

H

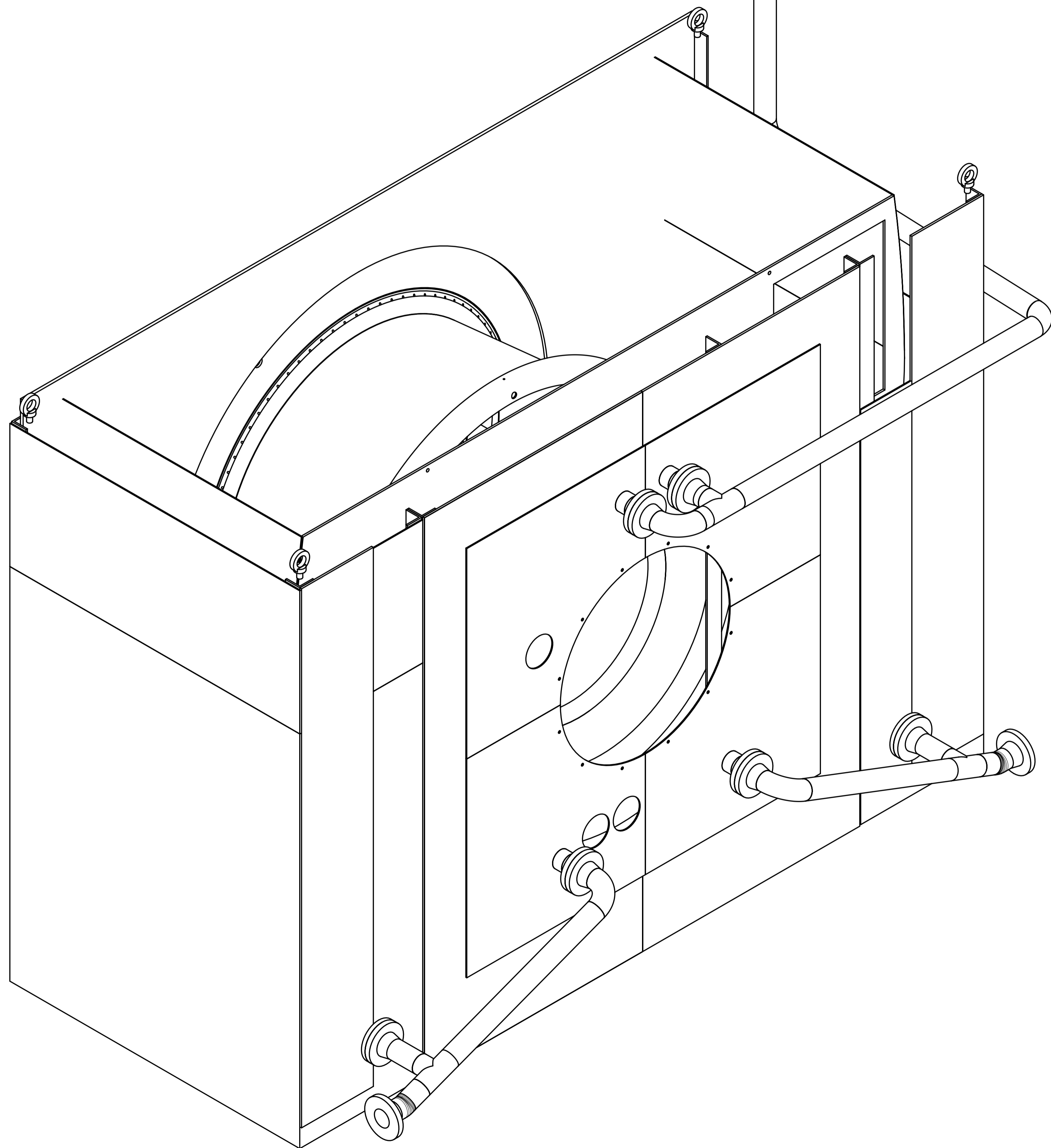

REV.	DATE	DESIGN	CHECK	APPROVED	DRAWING STATUS
THIS DRAWING HAS ELECTRONIC ORIGINAL WITH PRINTED SIGNATURES. THE DRAWING IS RELEASED WHEN BOTH DESIGN, CHECK AND APPROVED ABOVE ARE SIGNED.					
GEN. DRAWING RULES IN ACCORDANCE WITH ISO	DATE YYYY-MM-DD	CHECK -	SCALE 1:	DRESSER-RAND KONGSBERG - NORWAY	
DESIGN -	APPROVED -	SHEET SIZE A1	CLASSF.		
Title ga fab				REF.	PAGE OF
				DRW. No.	REV.
NX FILE: dl_3_exhaust case study LAST MODIFIED:-					

This drawing contains **Confidential and Trade Secret Information**, is the property of Dresser-Rand AS, and is provided to the receiver in confidence. The receiver by reception and retention of the drawing accepts the drawing in confidence and agrees that, except as authorized in writing by Dresser-Rand AS, it will (1) not use the drawing or any copy thereof or the confidential or trade secret information therein; (2) not copy the drawing; (3) not disclose to others either the drawing or the confidential or trade secret information therein; and (4) upon completion of the need to retain the drawing, or upon demand, return the drawing, and all copies thereof in any form.

1

2

3

4

5

6

7

8

9

10

11

12

1

2

3

4

5

6

7

8

9

10

11

12

A

B

C

D

E

F

G

H

A

B

C

D

E

F

G

H

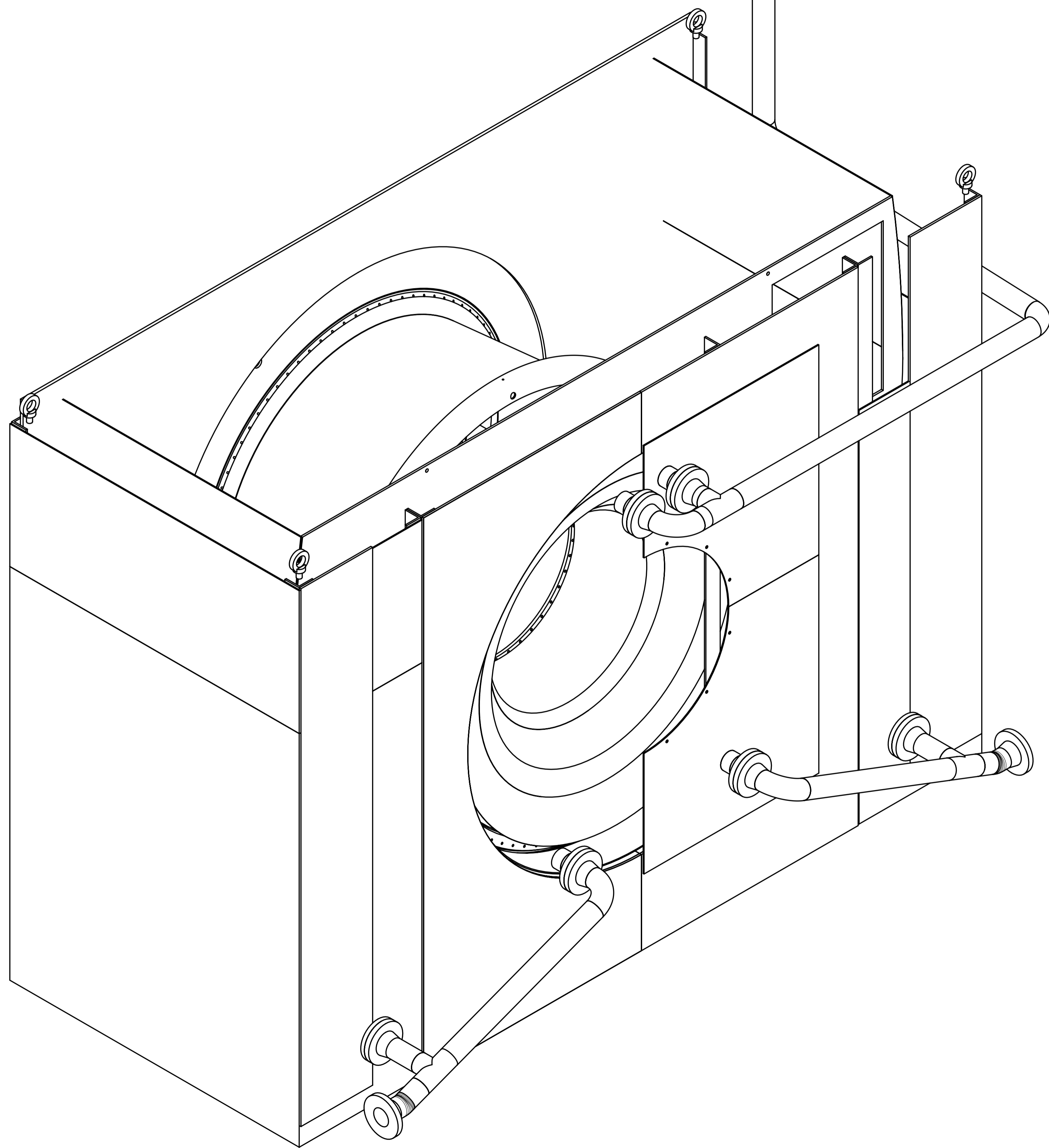

REV.	DATE	DESIGN	CHECK	APPROVED	DRAWING STATUS
THIS DRAWING HAS ELECTRONIC ORIGINAL WITH PRINTED SIGNATURES. THE DRAWING IS RELEASED WHEN BOTH DESIGN, CHECK AND APPROVED ABOVE ARE SIGNED.					
GEN. DRAWING RULES IN ACCORDANCE WITH ISO	DATE	YYYY-MM-DD	CHECK	SCALE	1:
	DESIGN	-	APPROVED	SHEET SIZE	A1
Title	ga fab		CLASSF.	REF.	PAGE OF
				DRW. No.	REV.
					DRESSER-RAND KONGSBERG - NORWAY REF. - - NX FILE: dl_3_exhaust case study LAST MODIFIED: -

This drawing contains **Confidential and Trade Secret Information**, is the property of Dresser-Rand AS, and is provided to the receiver in confidence. The receiver by reception and retention of the drawing accepts the drawing in confidence and agrees that, except as authorized in writing by Dresser-Rand AS, it will (1) not use the drawing or any copy thereof or the confidential or trade secret information therein; (2) not copy the drawing; (3) not disclose to others either the drawing or the confidential or trade secret information therein; and (4) upon completion of the need to retain the drawing, or upon demand, return the drawing, and all copies thereof in any form.

1

2

3

4

5

6

7

8

9

10

11

12

1 2 3 4 5 6 7 8 9 10 11 12

A

B

C

D

E

F

G

H

A

B

C

D

E

F

G

H

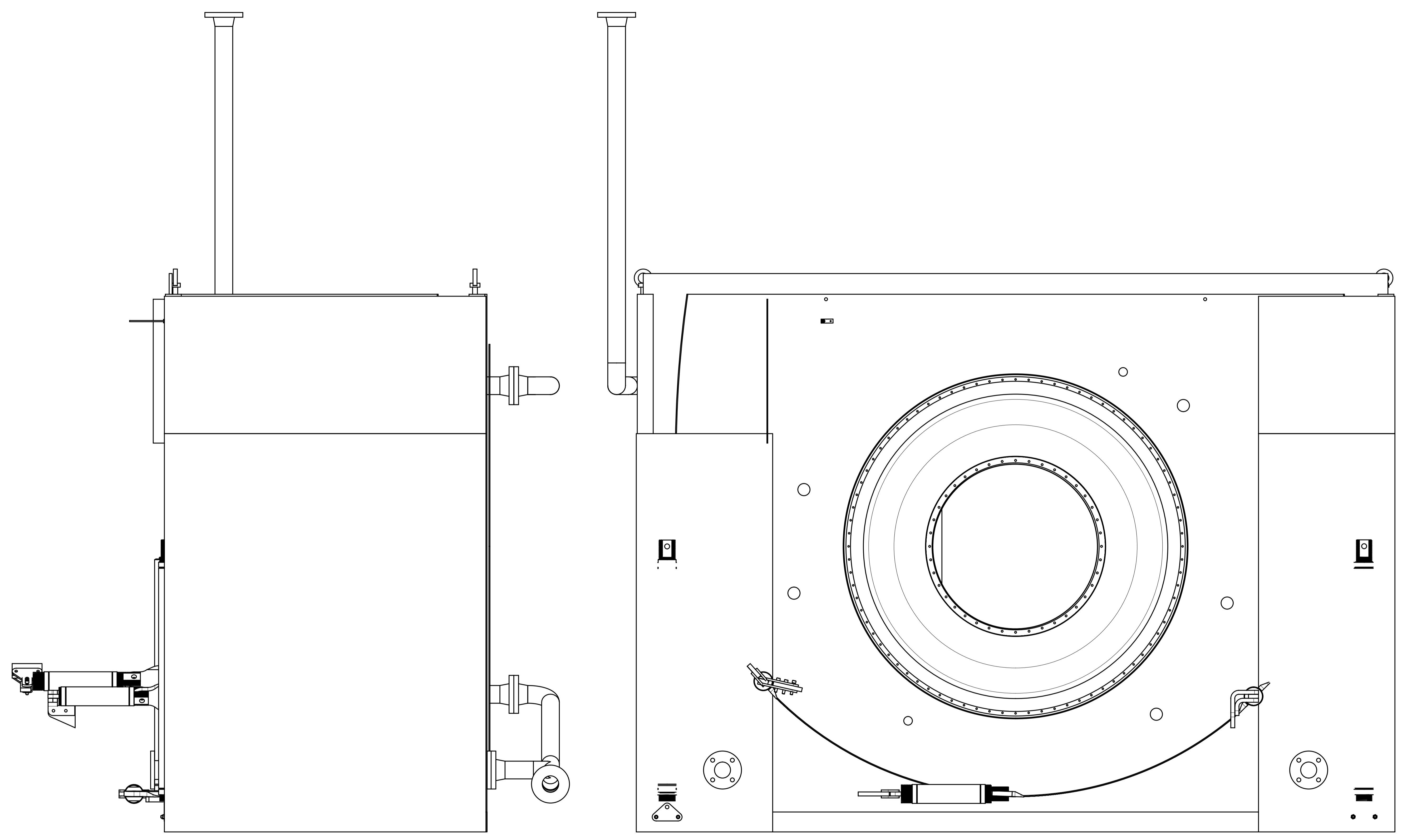

REV.	DATE	DESIGN	CHECK	APPROVED	DRAWING STATUS
THIS DRAWING HAS ELECTRONIC ORIGINAL WITH PRINTED SIGNATURES. THE DRAWING IS RELEASED WHEN BOTH DESIGN, CHECK AND APPROVED ABOVE ARE SIGNED.					
GEN. DRAWING RULES IN ACCORDANCE WITH ISO	DATE	YYYY-MM-DD	CHECK	SCALE	1:
	DESIGN	-	APPROVED	SHEET SIZE	A1
Title	ga fab			CLASSIF.	
DRW. No.					REV.
REF.					PAGE OF
NX FILE: dl_3_exhaust case study LAST MODIFIED:-					

This drawing contains **Confidential and Trade Secret Information**, is the property of Dresser-Rand AS, and is provided to the receiver in confidence. The receiver by reception and retention of the drawing accepts the drawing in confidence and agrees that, except as authorized in writing by Dresser-Rand AS, it will (1) not use the drawing or any copy thereof or the confidential or trade secret information therein; (2) not copy the drawing; (3) not disclose to others either the drawing or the confidential or trade secret information therein; and (4) upon completion of the need to retain the drawing, or upon demand, return the drawing, and all copies thereof in any form.

1 2 3 4 5 6 7 8 9 10 11 12

1

2

3

4

5

6

7

8

9

10

11

12

A

B

C

D

E

F

G

H

A

B

C

D

E

F

G

H

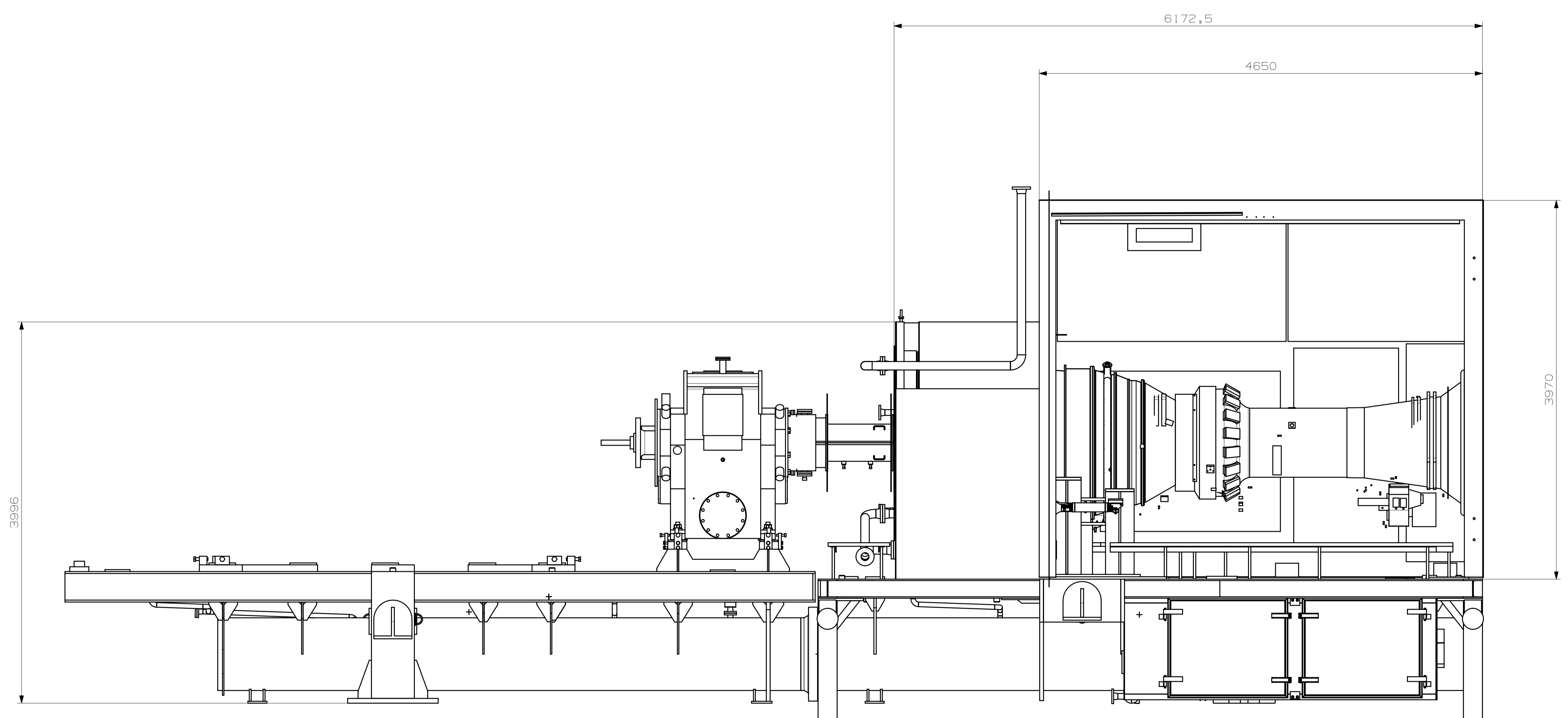

REV.	DATE	DESIGN	CHECK	APPROVED	DRAWING STATUS
THIS DRAWING HAS ELECTRONIC ORIGINAL WITH PRINTED SIGNATURES. THE DRAWING IS RELEASED WHEN BOTH DESIGN, CHECK AND APPROVED ABOVE ARE SIGNED.					
GEN. DRAWING RULES IN ACCORDANCE WITH ISO		DATE	CHECK	SCALE	
		YYYY-MM-DD	-	1:	
Title		DESIGN	APPROVED	SHEET SIZE	
		-	-	A1	
				CLASSF.	
				DRW. No.	
				REV.	
				REF.	
				PAGE	
				OF	
				REV.	
				LAST MODIFIED:	
				FILE: DL...first studys	
				LAST MODIFIED:	

This drawing contains **Confidential and Trade Secret Information**, is the property of Dresser-Rand AS, and is provided to the receiver in confidence. The receiver by reception and retention of the drawing accepts the drawing in confidence and agrees that, except as authorized in writing by Dresser-Rand AS, it will (1) not use the drawing or any copy thereof or the confidential or trade secret information therein; (2) not copy the drawing; (3) not disclose to others either the drawing or the confidential or trade secret information therein; and (4) upon completion of the need to retain the drawing, or upon demand, return the drawing, and all copies thereof in any form.

1

2

3

4

5

6

7

8

9

10

11

12

1

2

3

4

5

6

7

8

9

10

11

12

A

B

C

D

E

F

G

H

A

B

C

D

E

F

G

H

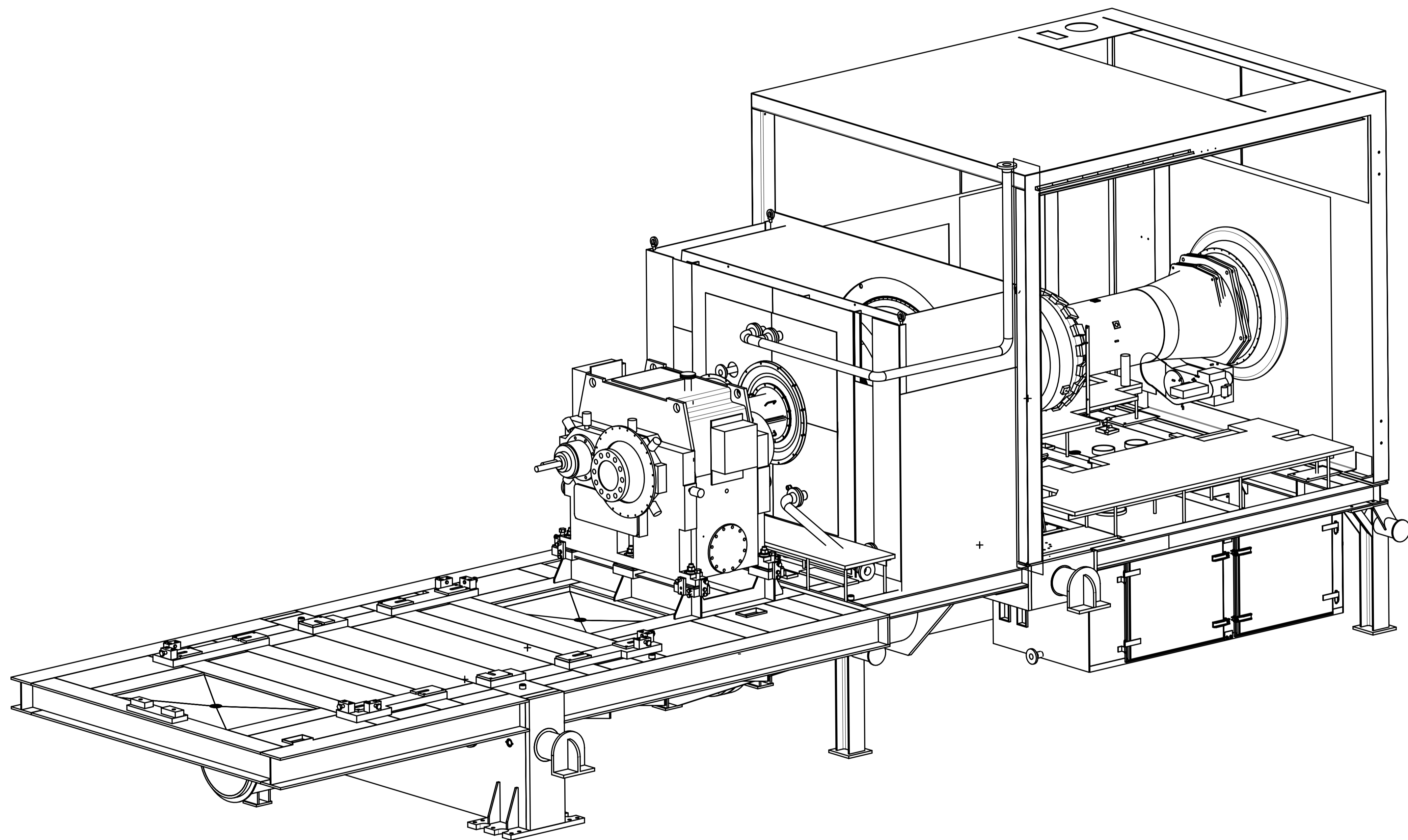

REV.	DATE	DESIGN	CHECK	APPROVED	DRAWING STATUS
THIS DRAWING HAS ELECTRONIC ORIGINAL WITH PRINTED SIGNATURES. THE DRAWING IS RELEASED WHEN BOTH DESIGN, CHECK AND APPROVED ABOVE ARE SIGNED.					
GEN. DRAWING RULES IN ACCORDANCE WITH ISO	DATE	YYYY-MM-DD	CHECK	SCALE	1:
			DESIGN	APPROVED	SHEET SIZE A1
Title					CLASSF.
-					REF.
-					PAGE
-					OF
-					REV.
-					DRW. No.
-					LAST MODIFIED:-

This drawing contains **Confidential and Trade Secret Information**, is the property of Dresser-Rand AS, and is provided to the receiver in confidence. The receiver by reception and retention of the drawing accepts the drawing in confidence and agrees that, except as authorized in writing by Dresser-Rand AS, it will (1) not use the drawing or any copy thereof or the confidential or trade secret information therein; (2) not copy the drawing; (3) not disclose to others either the drawing or the confidential or trade secret information therein; and (4) upon completion of the need to retain the drawing, or upon demand, return the drawing, and all copies thereof in any form.

1

2

3

4

5

6

7

8

9

10

11

12

1 2 3 4 5 6 7 8 9 10 11 12

A

B

C

D

E

F

G

H

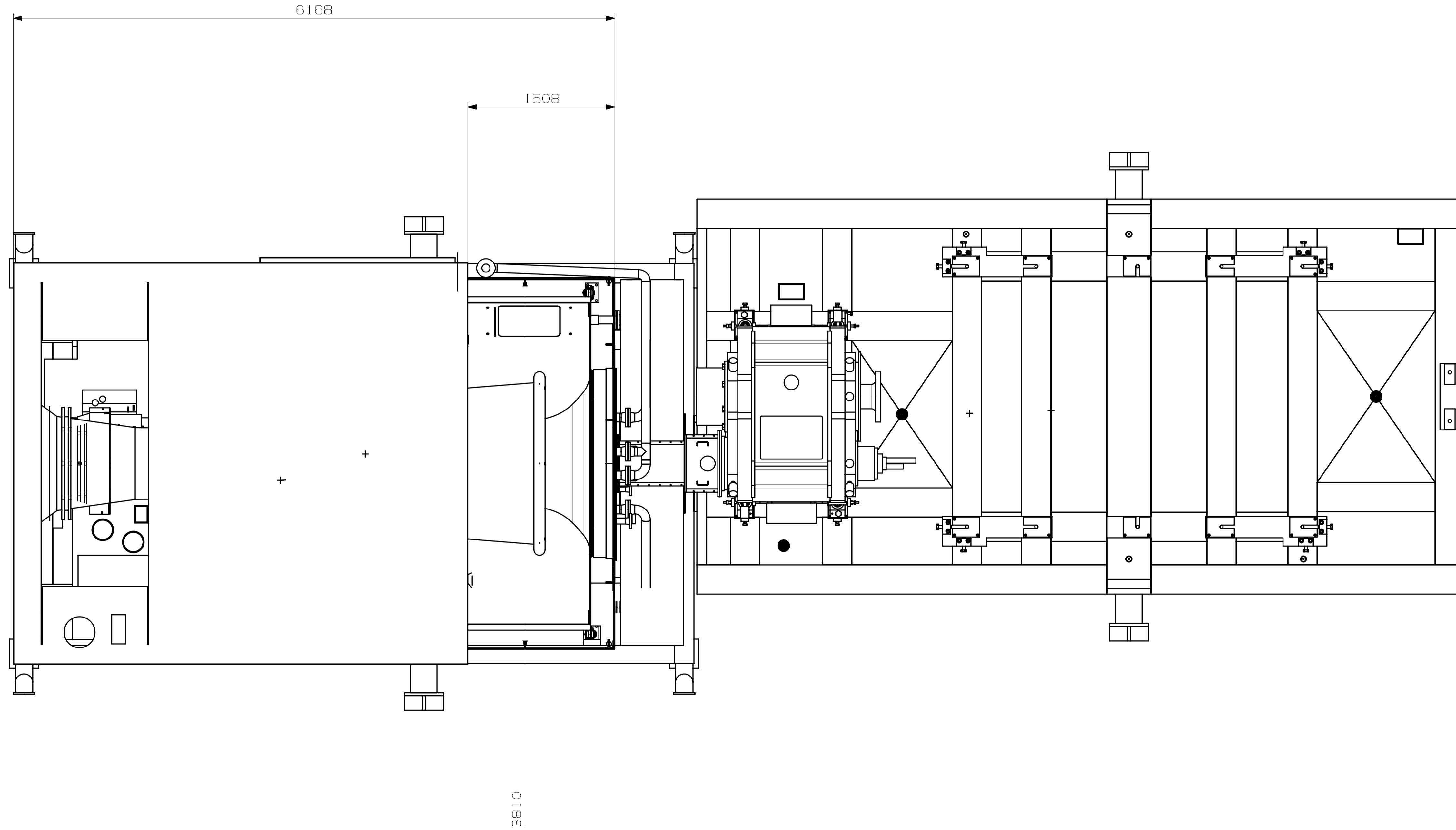

REV.	DATE	DESIGN	CHECK	APPROVED	DRAWING STATUS
THIS DRAWING HAS ELECTRONIC ORIGINAL WITH PRINTED SIGNATURES. THE DRAWING IS RELEASED WHEN BOTH DESIGN, CHECK AND APPROVED ABOVE ARE SIGNED.					
GEN. DRAWING RULES IN ACCORDANCE WITH ISO	DATE	YYYY-MM-DD	CHECK	SCALE	1:
			DESIGN	APPROVED	SHEET SIZE A1
Title					CLASSIF.
-					REF.
-					PAGE
-					OF
-					REV.
-					DRW. No.
-					REF.
-					LAST MODIFIED:-

This drawing contains **Confidential and Trade Secret Information**, is the property of Dresser-Rand AS, and is provided to the receiver in confidence. The receiver by reception and retention of the drawing accepts the drawing in confidence and agrees that, except as authorized in writing by Dresser-Rand AS, it will (1) not use the drawing or any copy thereof or the confidential or trade secret information therein; (2) not copy the drawing; (3) not disclose to others either the drawing or the confidential or trade secret information therein; and (4) upon completion of the need to retain the drawing, or upon demand, return the drawing, and all copies thereof in any form.

1 2 3 4 5 6 7 8 9 10 11 12

1

2

3

4

5

6

7

8

9

10

11

12

A

B

C

D

E

F

G

H

A

B

C

D

E

F

G

H

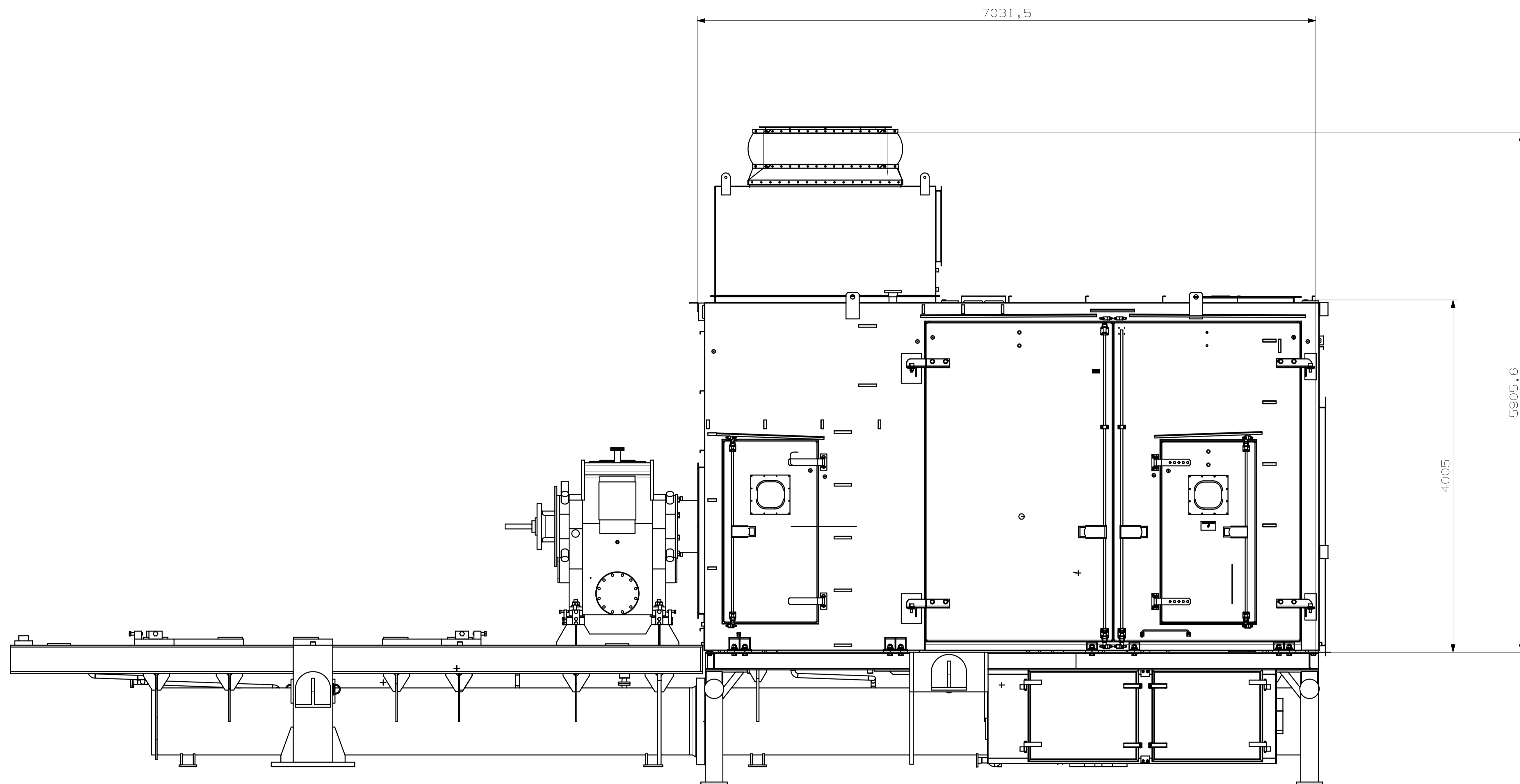

REV.	DATE	DESIGN	CHECK	APPROVED	DRAWING STATUS
THIS DRAWING HAS ELECTRONIC ORIGINAL WITH PRINTED SIGNATURES. THE DRAWING IS RELEASED WHEN BOTH DESIGN, CHECK AND APPROVED ABOVE ARE SIGNED.					
GEN. DRAWING RULES IN ACCORDANCE WITH ISO	DATE	YYYY-MM-DD	CHECK	SCALE	1:
DESIGN	-	-	APPROVED	-	SHEET SIZE A1
CLASSF.	CLASSF.				REF.
old ga	-				DRW. No.
-	-				REV.
-	-				REF.
-	-				LAST MODIFIED:-

This drawing contains **Confidential and Trade Secret Information**, is the property of Dresser-Rand AS, and is provided to the receiver in confidence. The receiver by reception and retention of the drawing accepts the drawing in confidence and agrees that, except as authorized in writing by Dresser-Rand AS, it will (1) not use the drawing or any copy thereof or the confidential or trade secret information therein; (2) not copy the drawing; (3) not disclose to others either the drawing or the confidential or trade secret information therein; and (4) upon completion of the need to retain the drawing, or upon demand, return the drawing, and all copies thereof in any form.

1

2

3

4

5

6

7

8

9

10

11

12

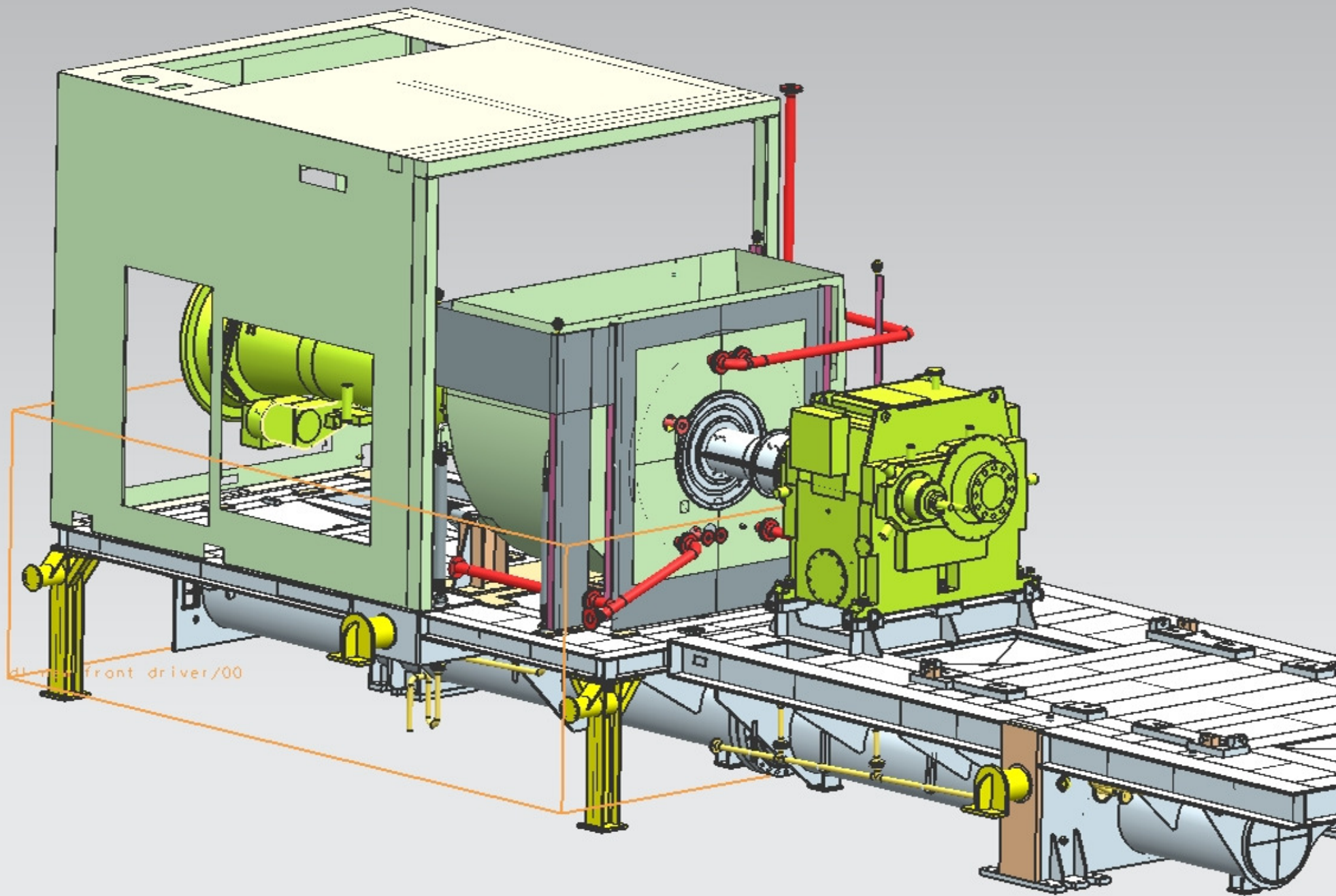

drive front driver/00

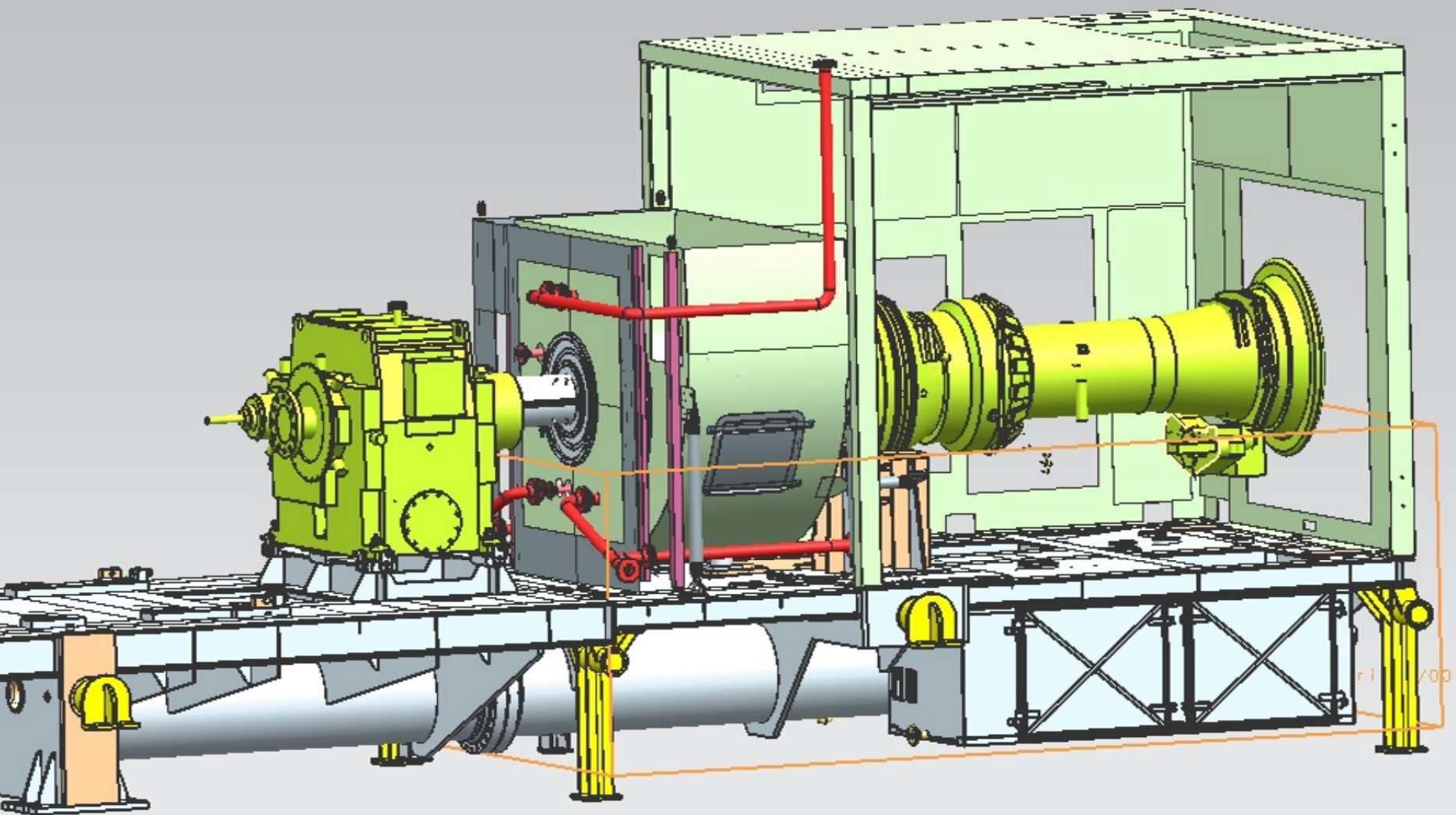

r1 / 00

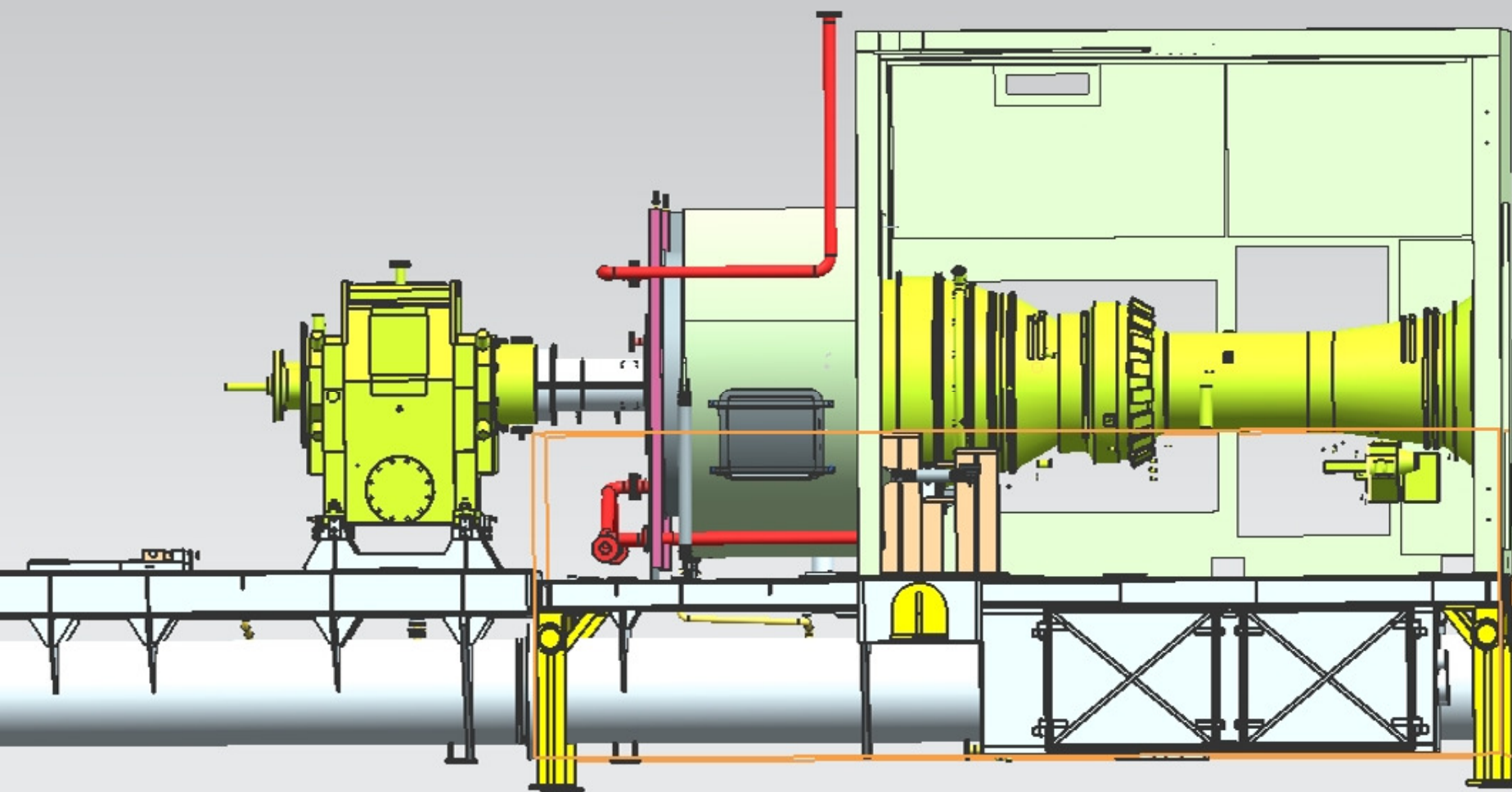

and new front driv

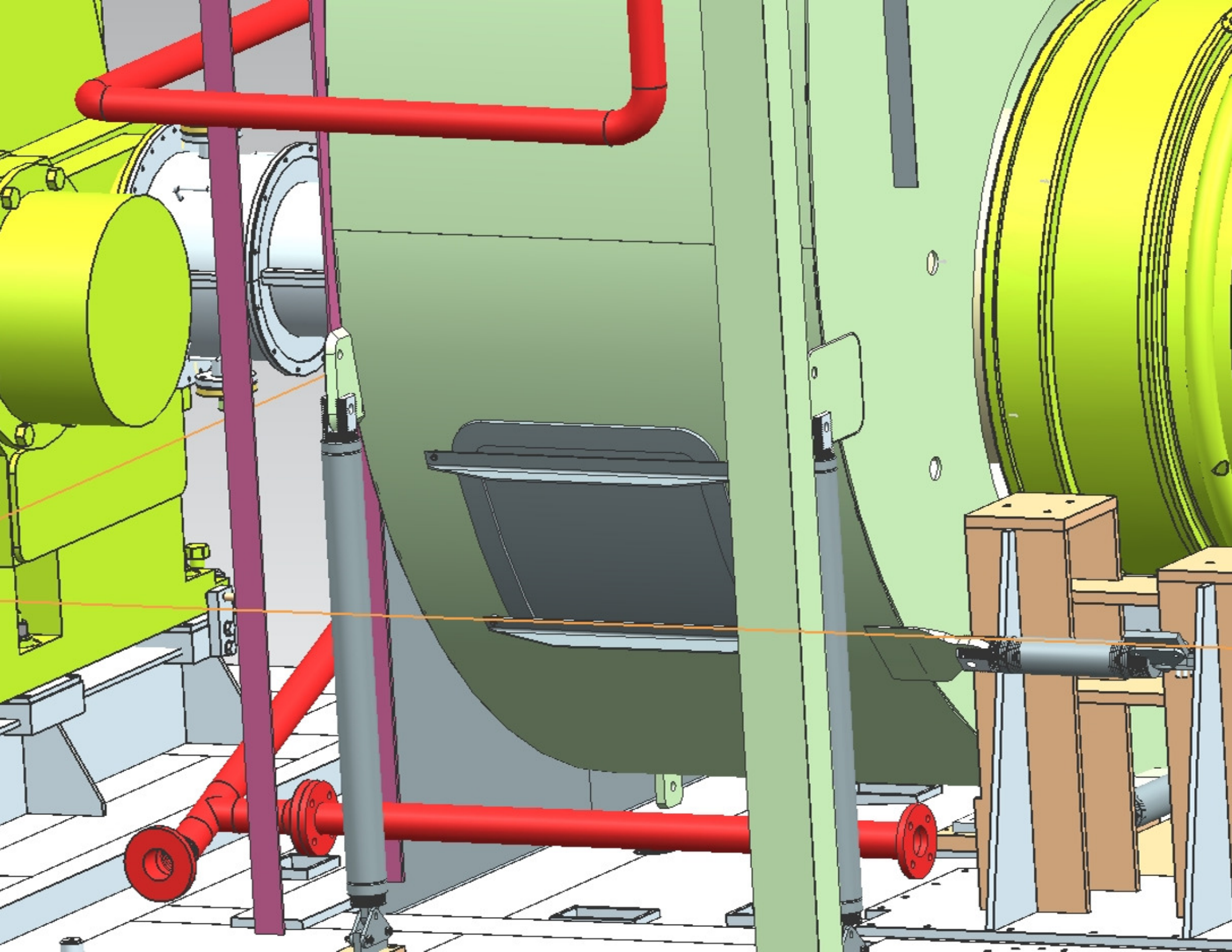

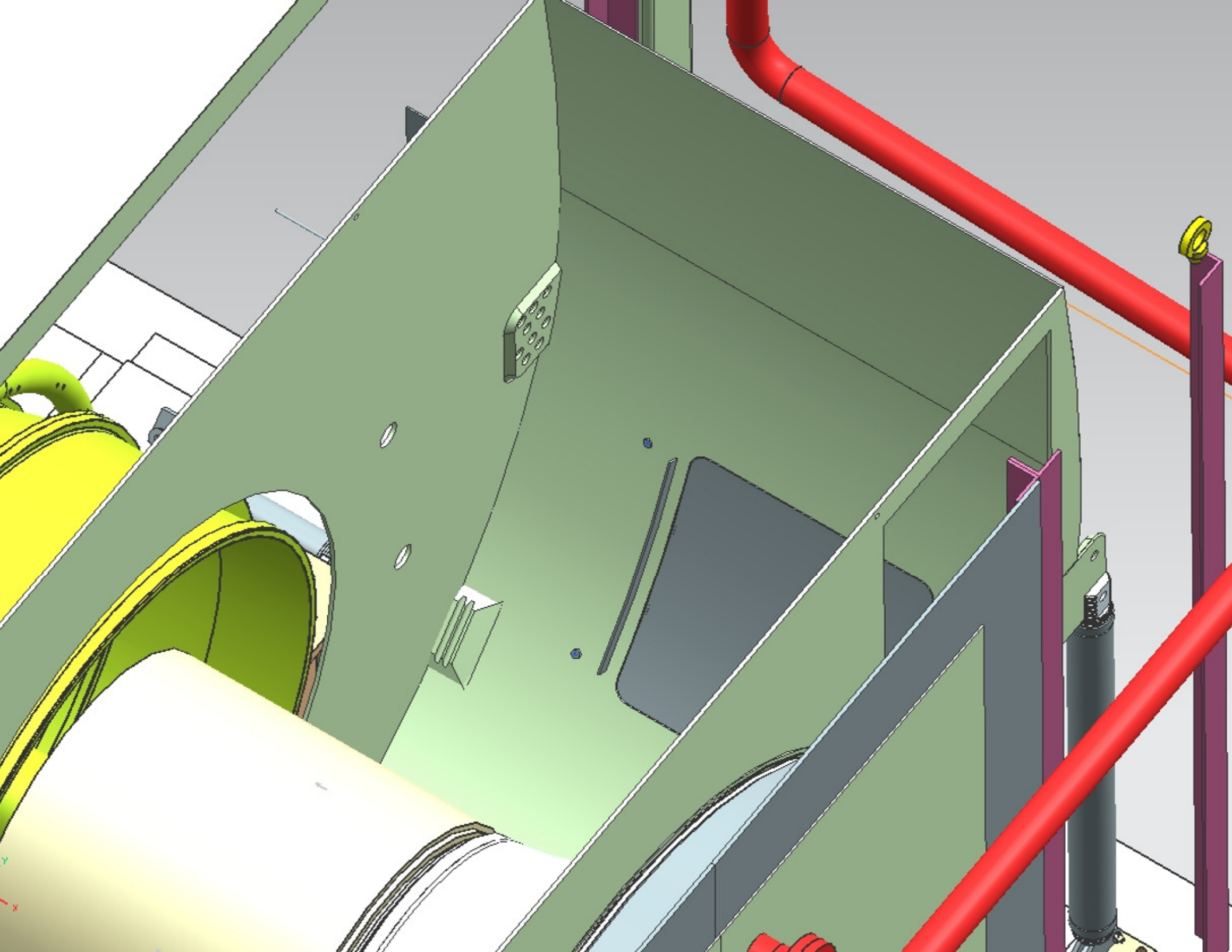

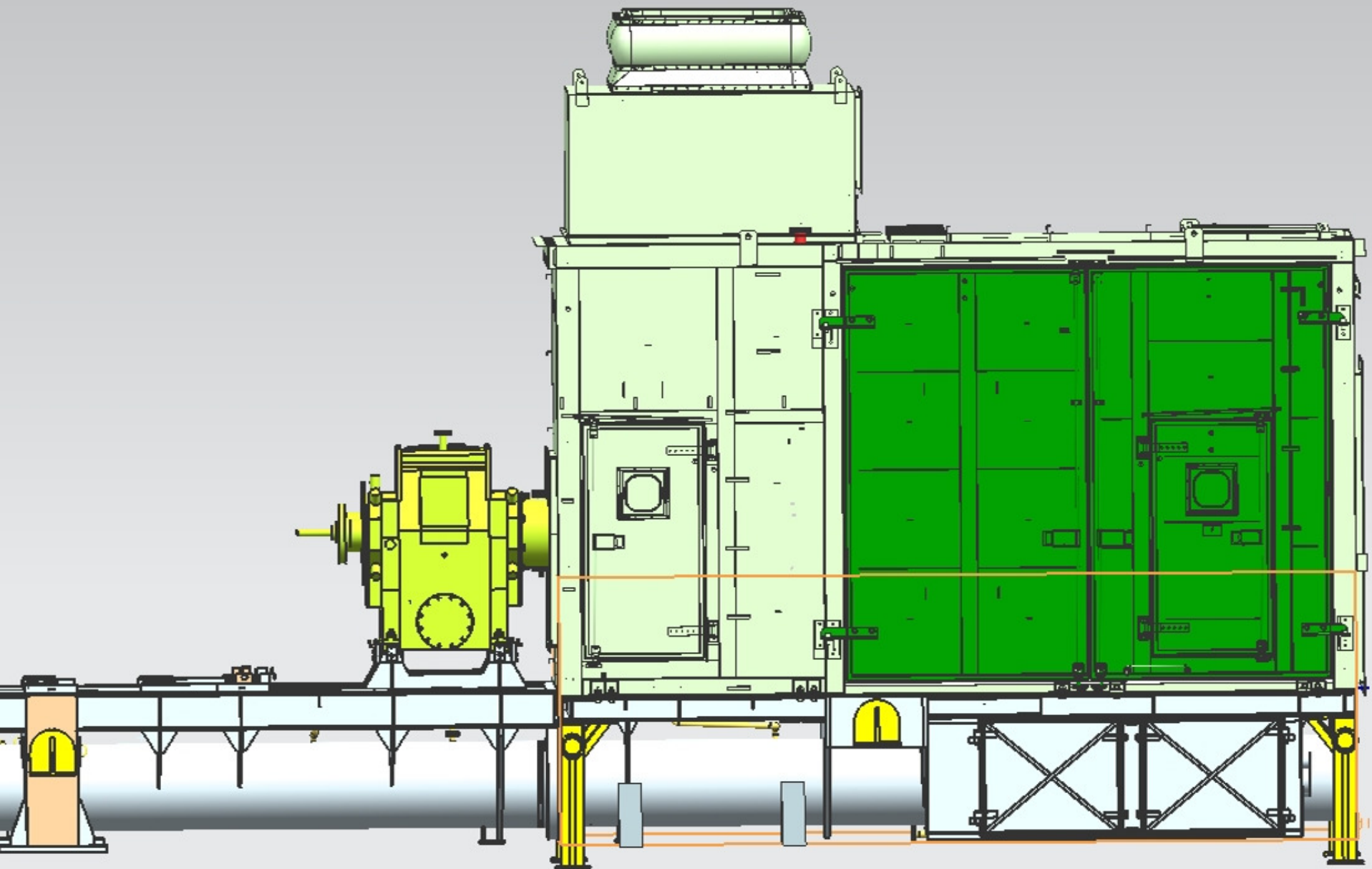

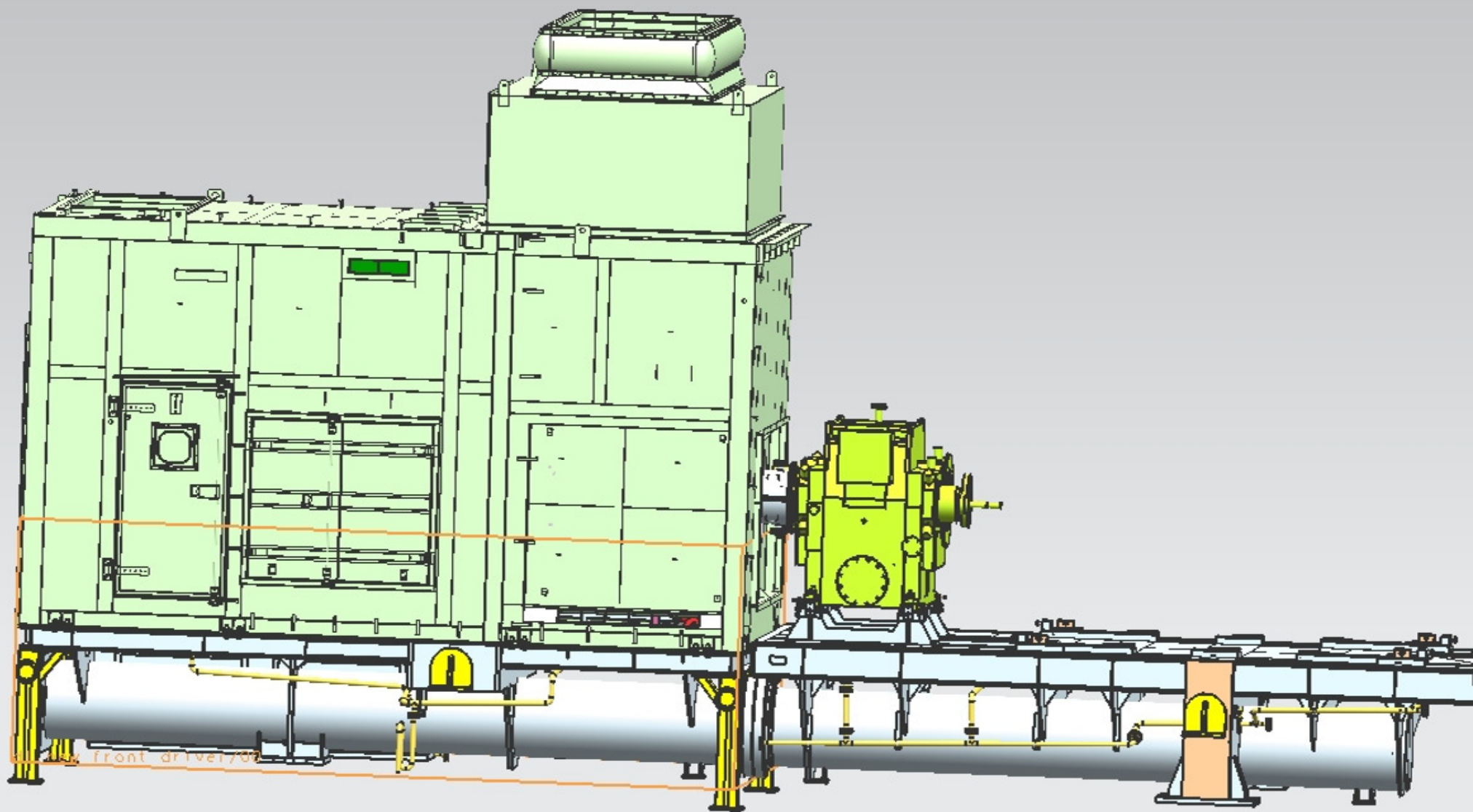

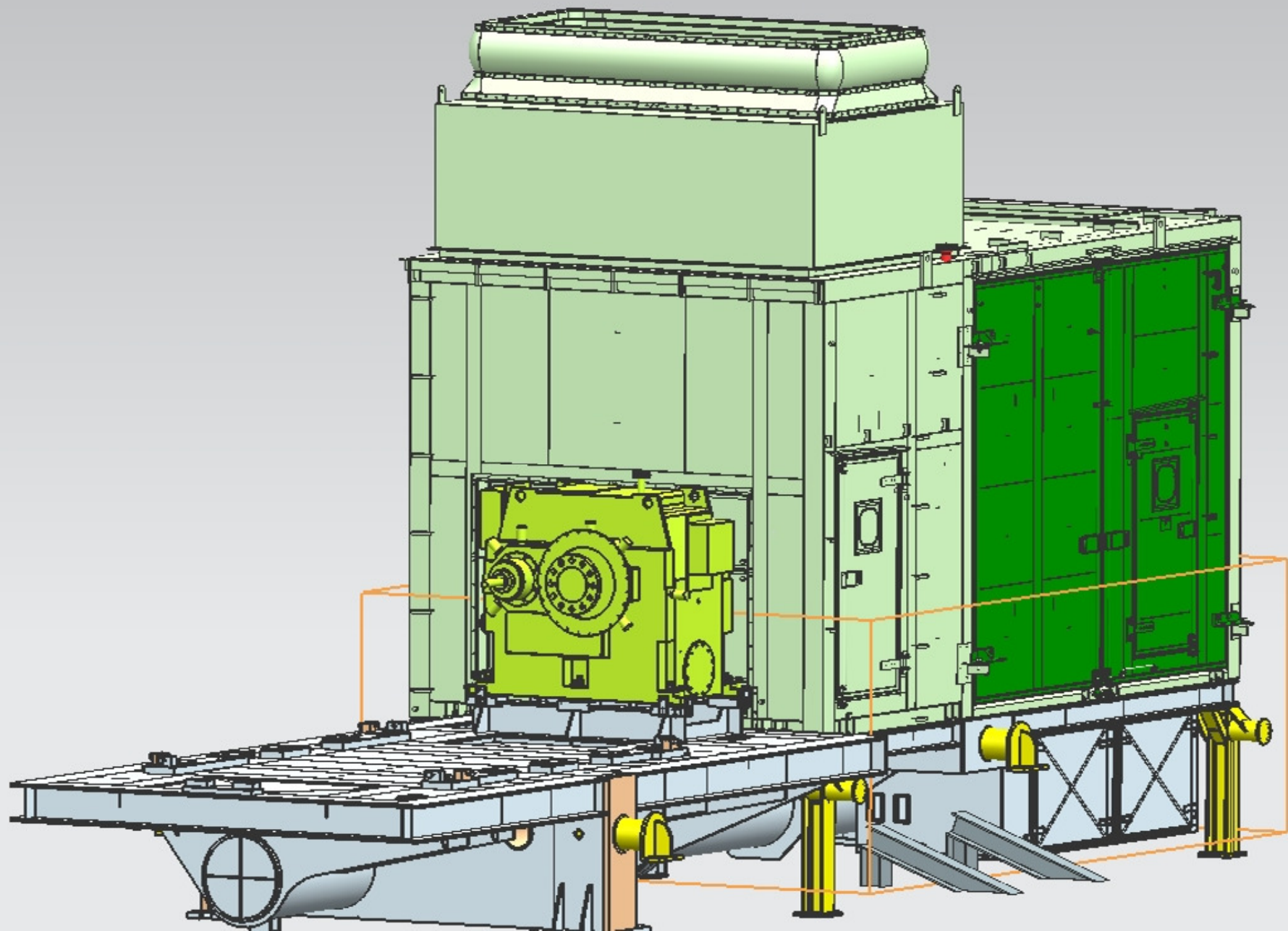

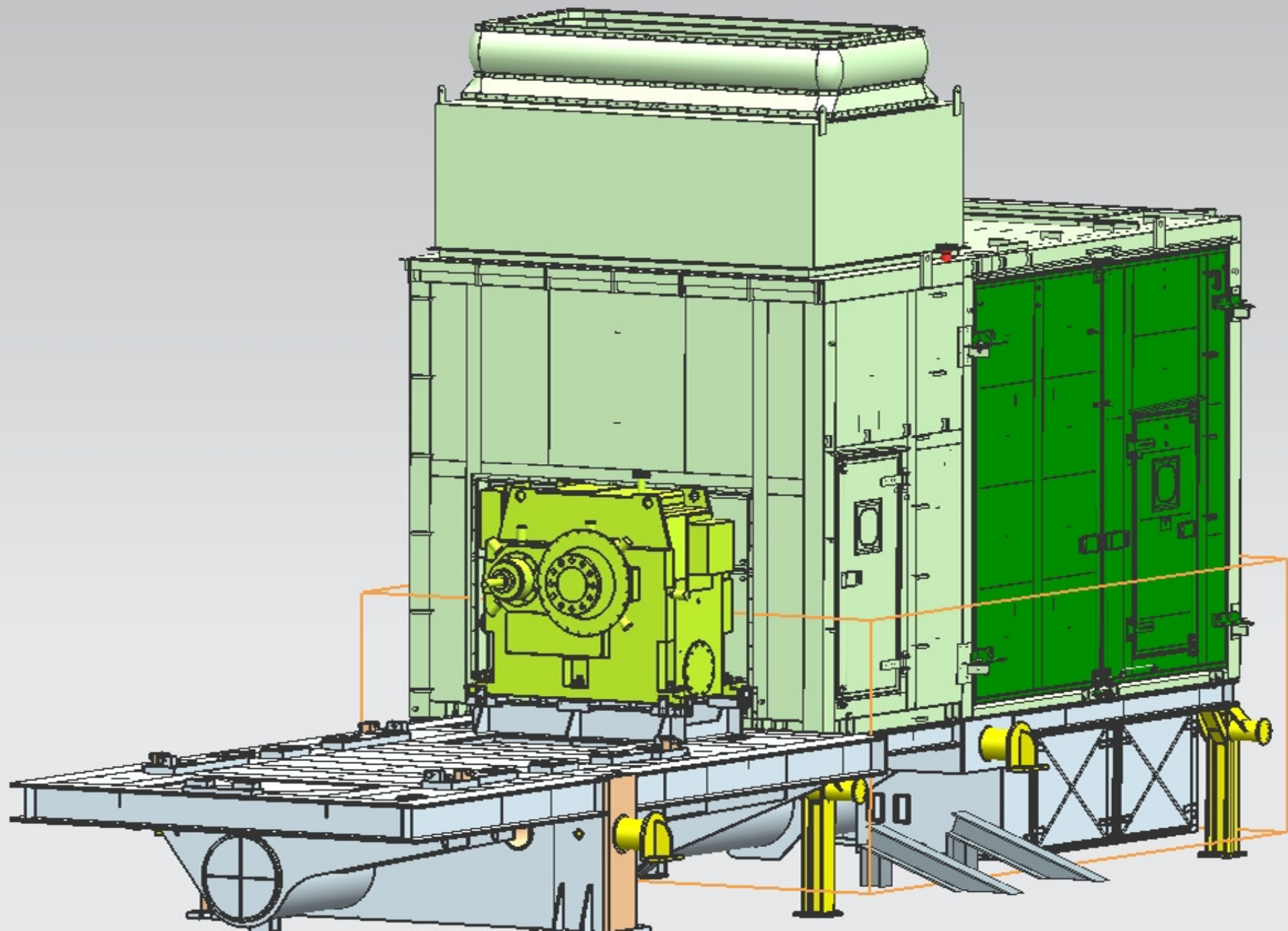

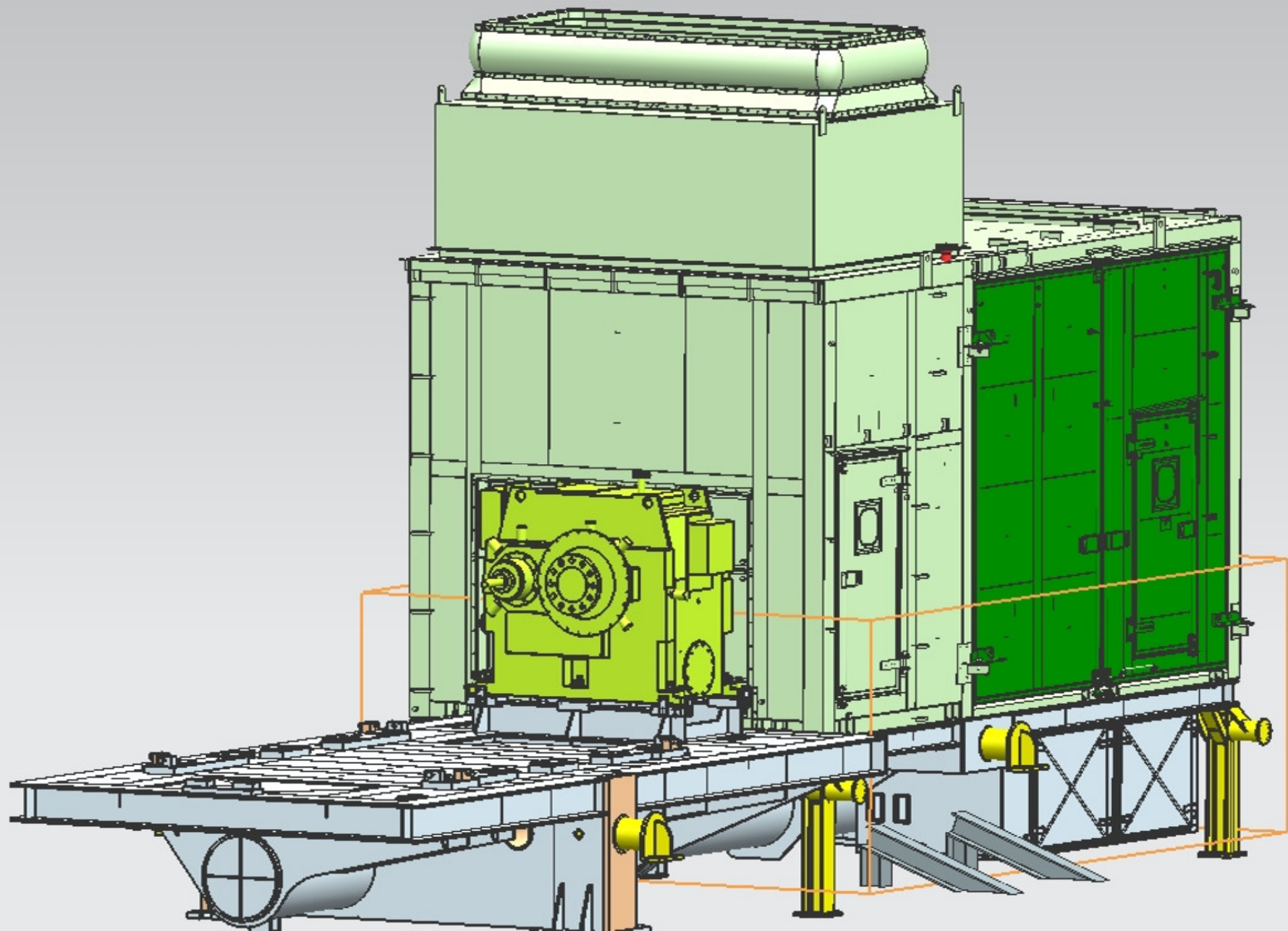

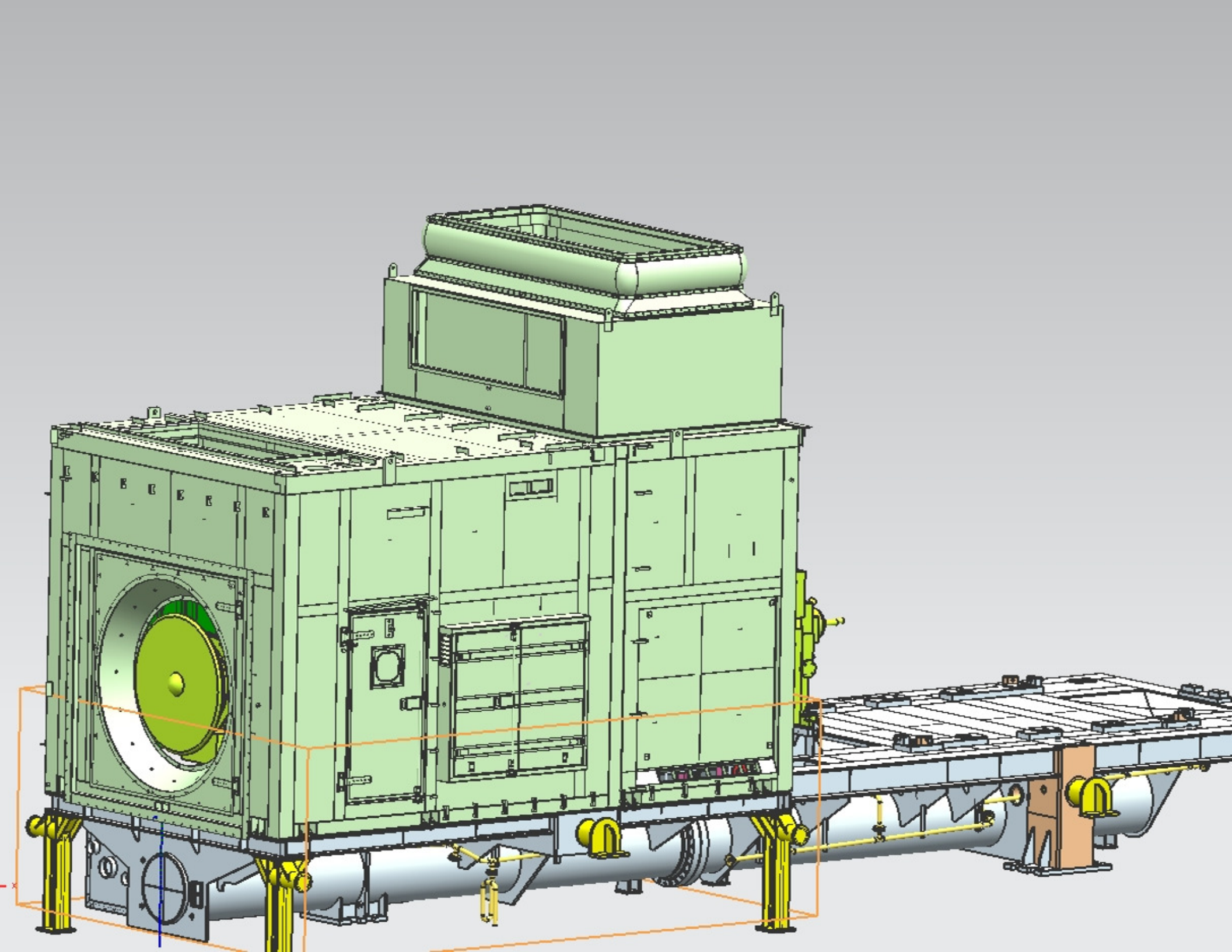

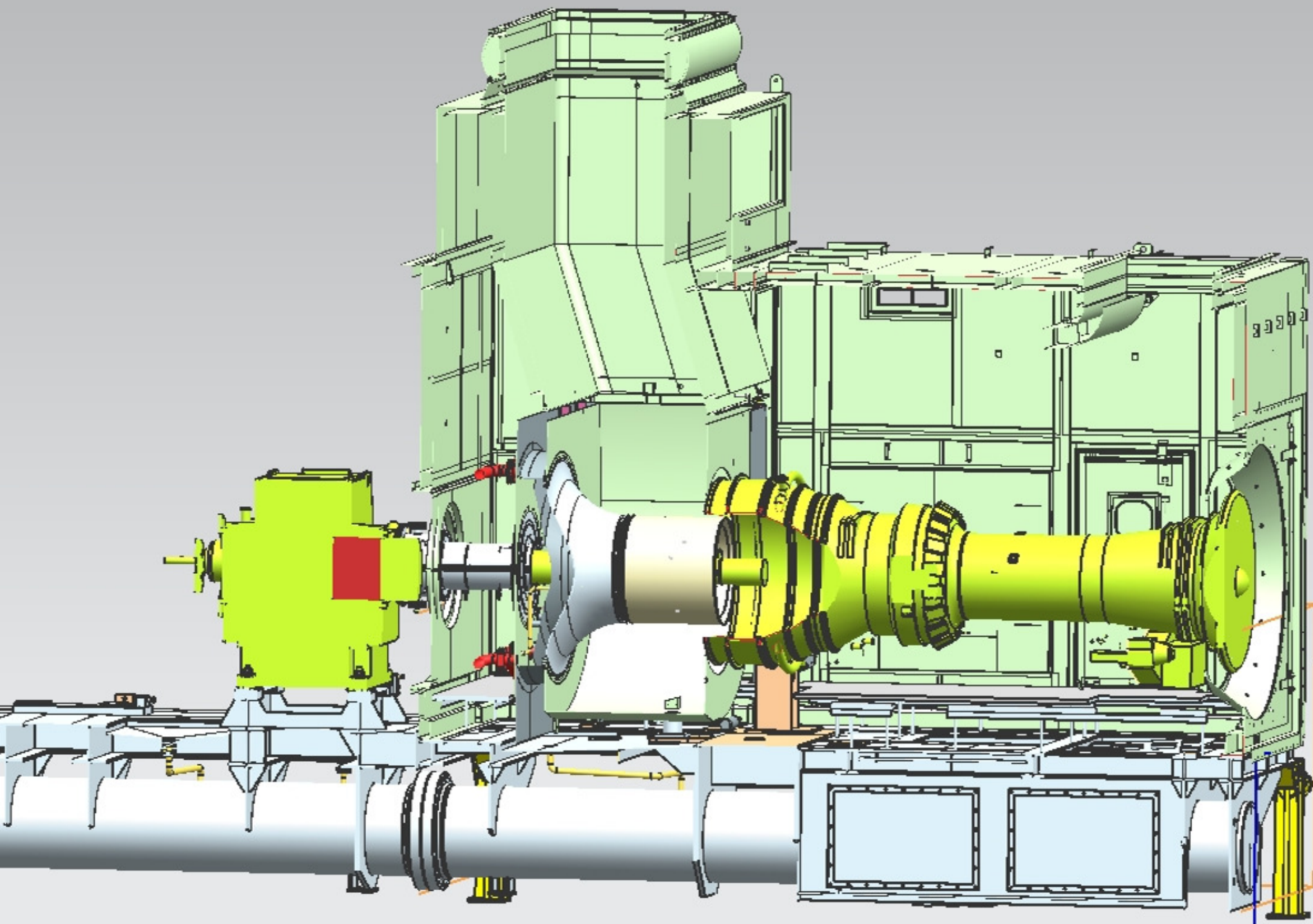

di new front e

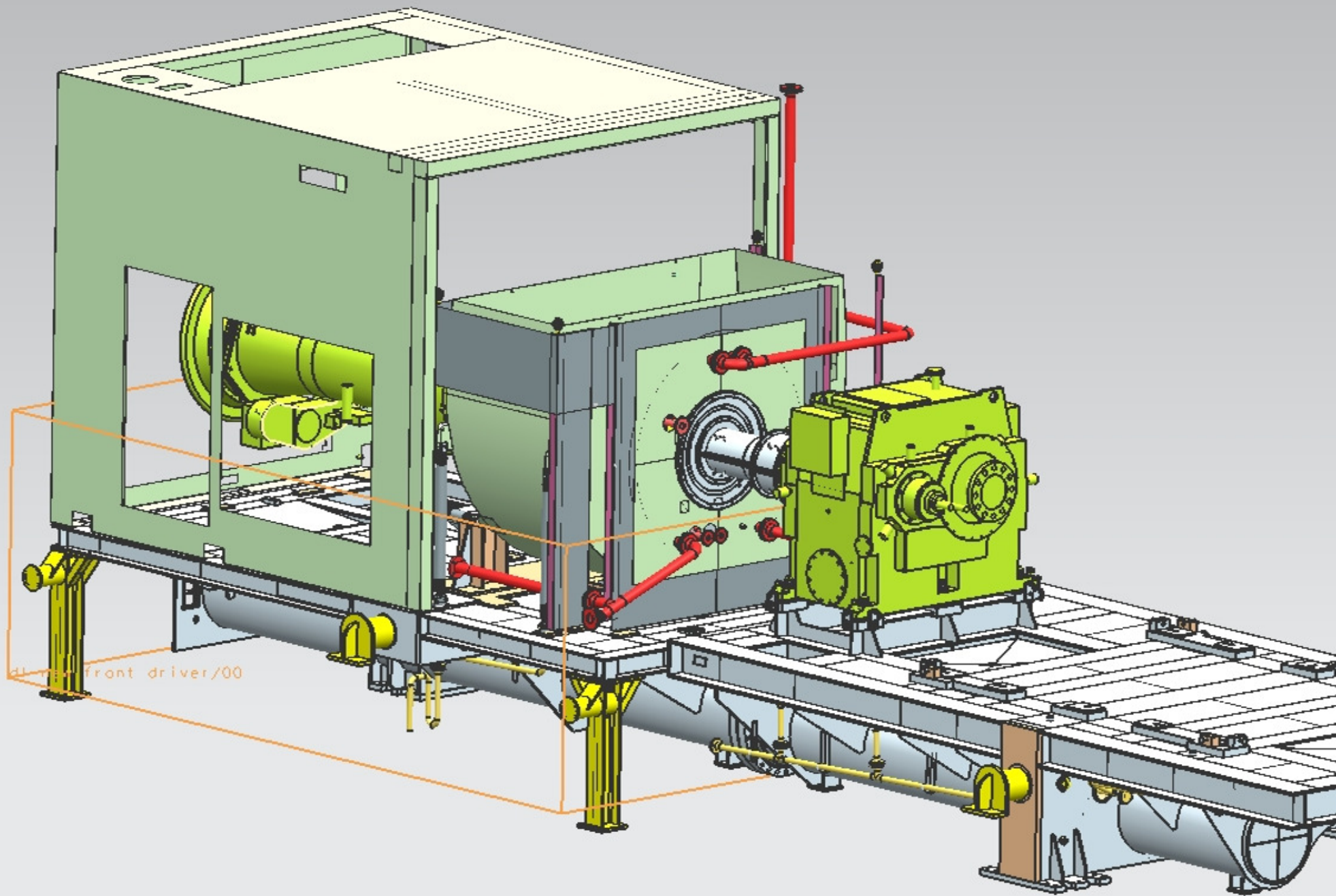

dl-front driver/00